

ASSEMBLY INSTRUCTION

Thank you for purchasing this quality product. Be sure to check all packing material carefully for small parts which may have come loose inside the carton during shipment. Separate, identify and count all parts and hardware. Compare with the parts list to be sure all parts are present.

IMPORTANT : PLEASE READ INSTRUCTION BEFORE STARTING THE ASSEMBLY.

"DO NOT TIGHTEN SCREWS UNTIL COMPLETELY ASSEMBLED"

"DO NOT OVERTIGHT ANY HARDWARE"

WARNING : SMALL PARTS AND HARDWARE NOT FOR CHILDREN UNDER 3 YEARS. ADULT ASSEMBLY REQUIRED.

TABLE OF CONTENTS

HARDWARES LIST	PAGE 2
PARTS LIST	PAGE 3
PARTS' LOCATION	PAGE 4
DESCRIPTION	PAGE 5
ASSEMBLY STEPS	PAGE 6 - 8
ASSEMBLY COMPLETED	PAGE 8

ASSEMBLY TOOLS REQUIRED

1. Screwdriver (not provide)

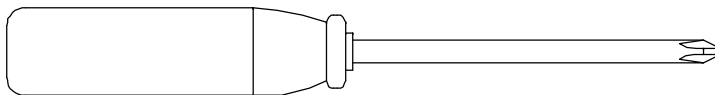



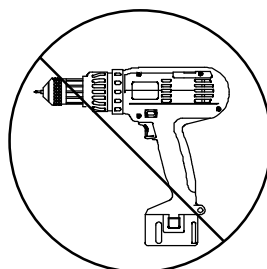

Skip the power trip this time.

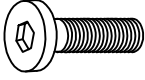
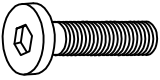
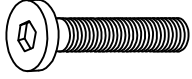
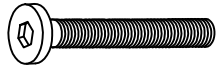
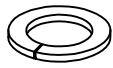
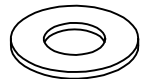

ASSEMBLY INSTRUCTION

HARDWARES LIST

ITEM	DESCRIPTION	DRAWING	QTY
A	JCBB SCREW M8 x 20MM		8 PCS
B	JCBB SCREW M8 x 25MM		8 PCS
C	JCBB SCREW M8 x 35MM		6 PCS
D	JCBC SCREW M6 x 35MM		4 PCS
E	SPRING WASHER M8 x 14MM		14 PCS
F	SPRING WASHER M8 x 22MM		14 PCS
G	CSK C/B SCREW (M4 x 32MM)		8 PCS
H	M4 ALLEN KEY (65MM)		1 PC
I	M5 ALLEN KEY (65MM)		1 PC

ASSEMBLY INSTRUCTION

PARTS LIST

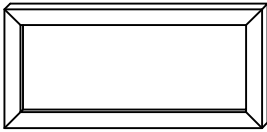
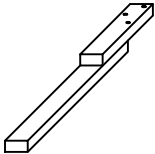
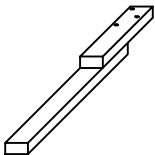
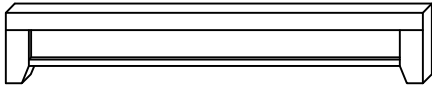
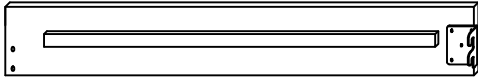
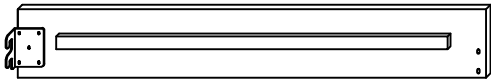
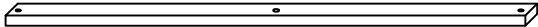
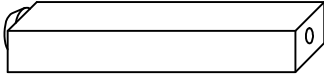
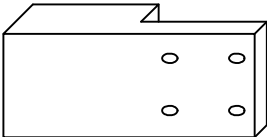
ITEM	DESCRIPTION	DRAWING	QTY
1	HEADBOARD		1 PC
2	HEADBOARD SUPPORT RAIL(R)		1 PC
3	HEADBOARD SUPPORT RAIL(L)		1 PC
4	FOOTBOARD		1 PC
5	SIDE RAIL (i)		2 PCS
6	SIDE RAIL (ii)		2 PCS
7	SLAT		4 PCS
8	CENTRE SUPPORT LEG		4 PCS
9	SIDE RAIL SUPPORT RAIL		2 PCS

ASSEMBLY INSTRUCTION

PARTS ' LOCATION

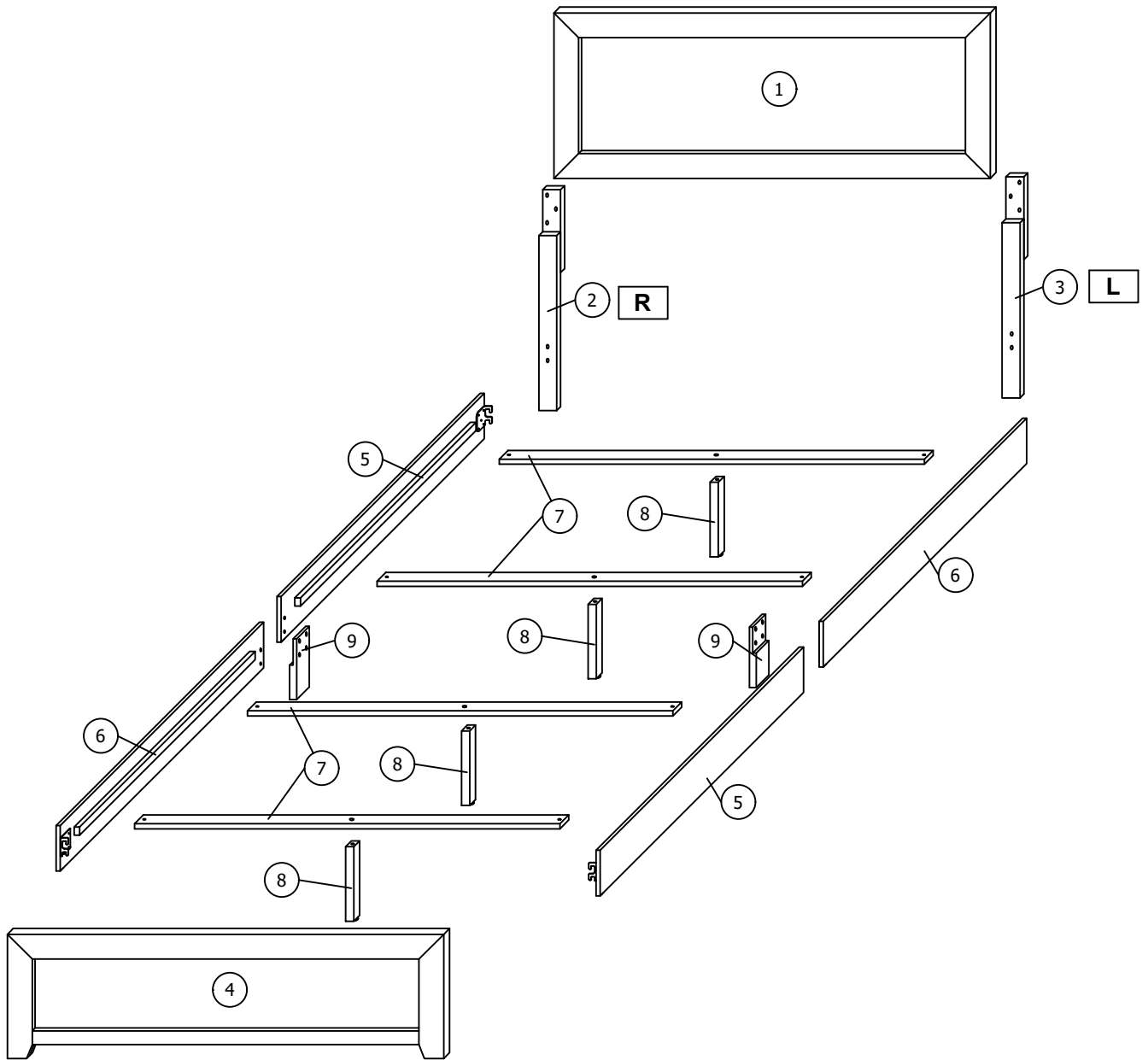

ASSEMBLY INSTRUCTION

DESCRIPTION

There are two stickers pre-sticked on backside of HEADBOARD(1) which separately marked with L and R .

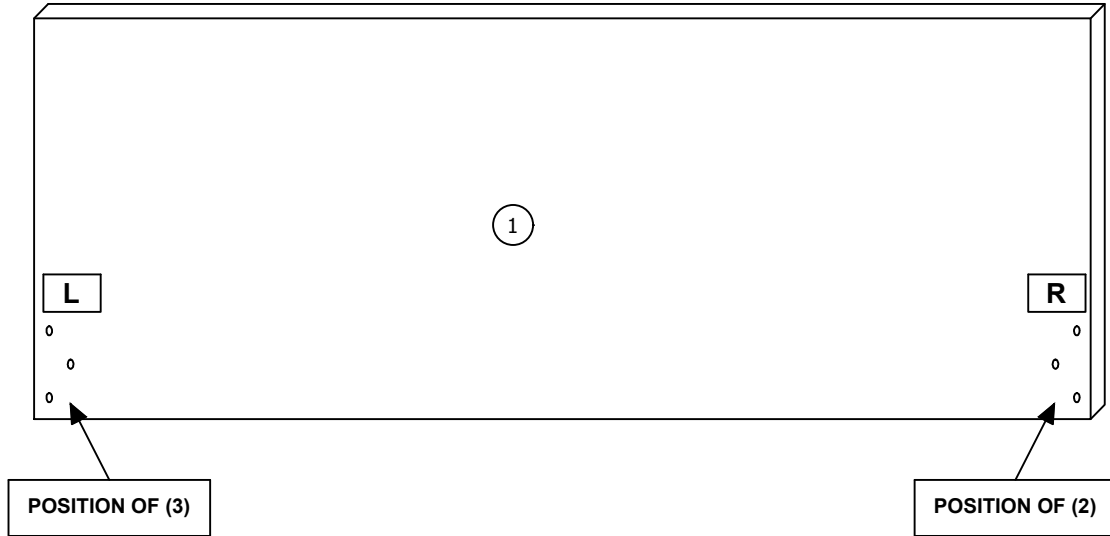

There is a sticker pre-sticked on backside of HEADBOARD SUPPORT RAIL(R)-(2) which marked with R .
There is a sticker pre-sticked on backside of HEADBOARD SUPPORT RAIL(L)-(3) which marked with L .

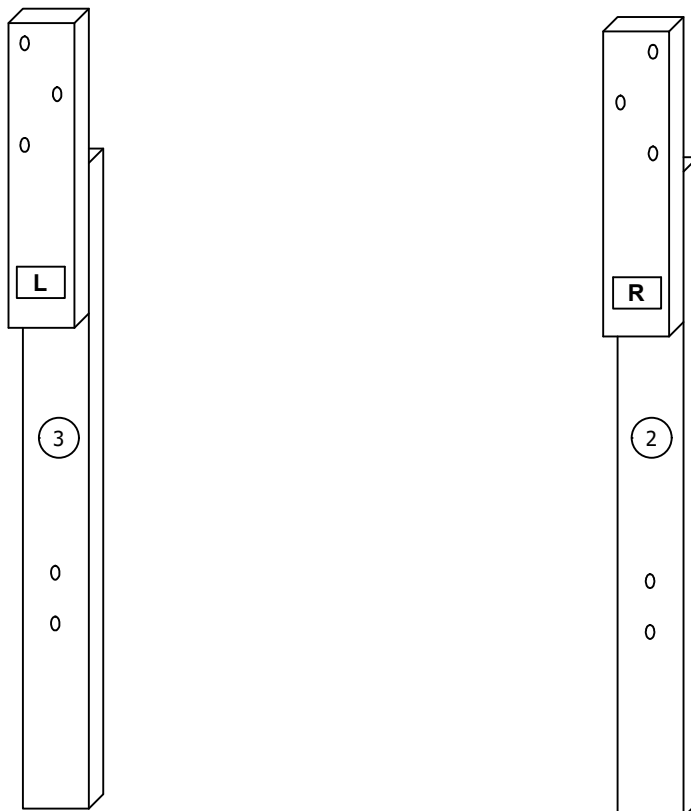

ASSEMBLY INSTRUCTION

ASSEMBLY STEPS

STEP 1

Use 1 piece JCBC SCREW (D) to combine 1 piece SLAT (7) and 1 piece CENTRE SUPPORT LEG (8) as shown. This step needs to be **done four times**.

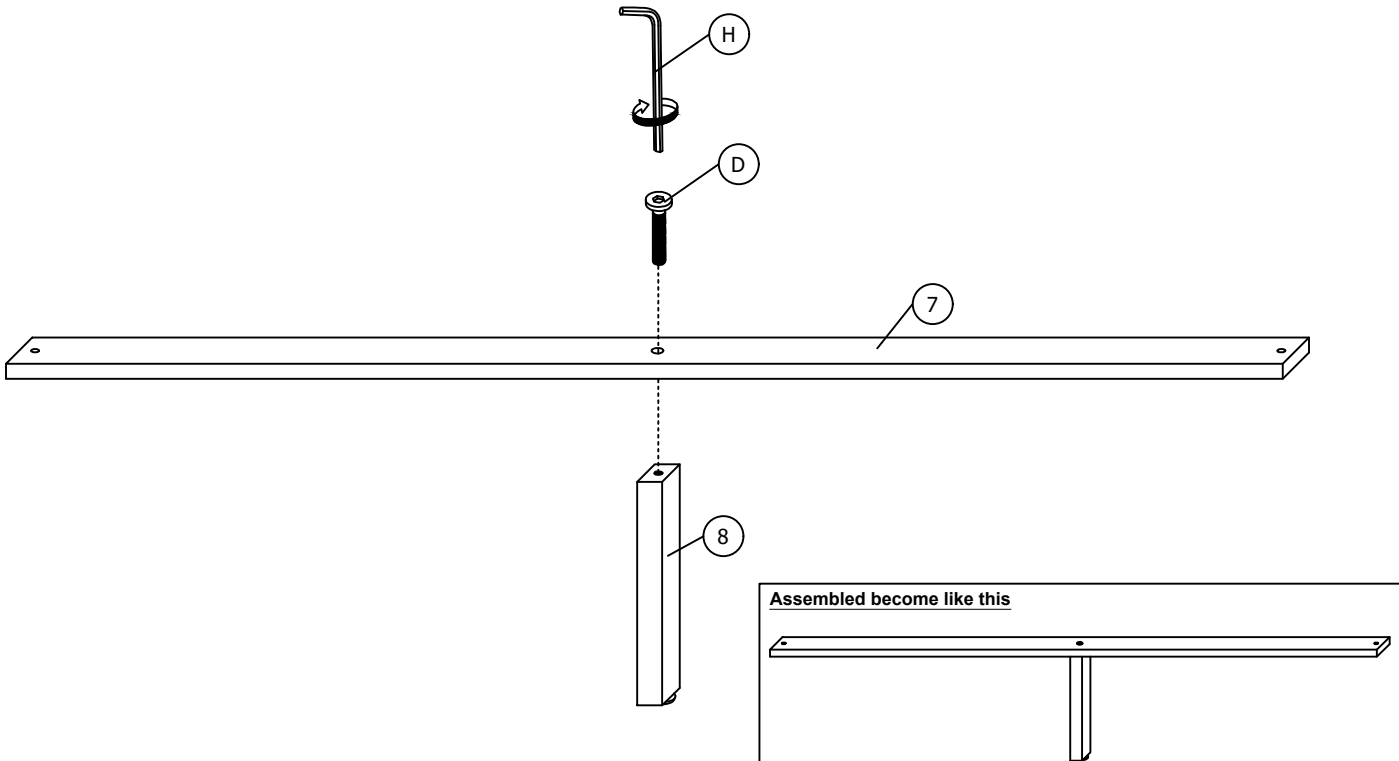

STEP 2

Align the position of hole then put the HEADBOARD SUPPORT RAIL (L) and (R)-(2) and(3) on the backside of HEADBOARD (1). After that , insert the 6 pieces JCBB SCREW (C), SPRING WASHER (E) and FLAT WASHER (F) as shown.

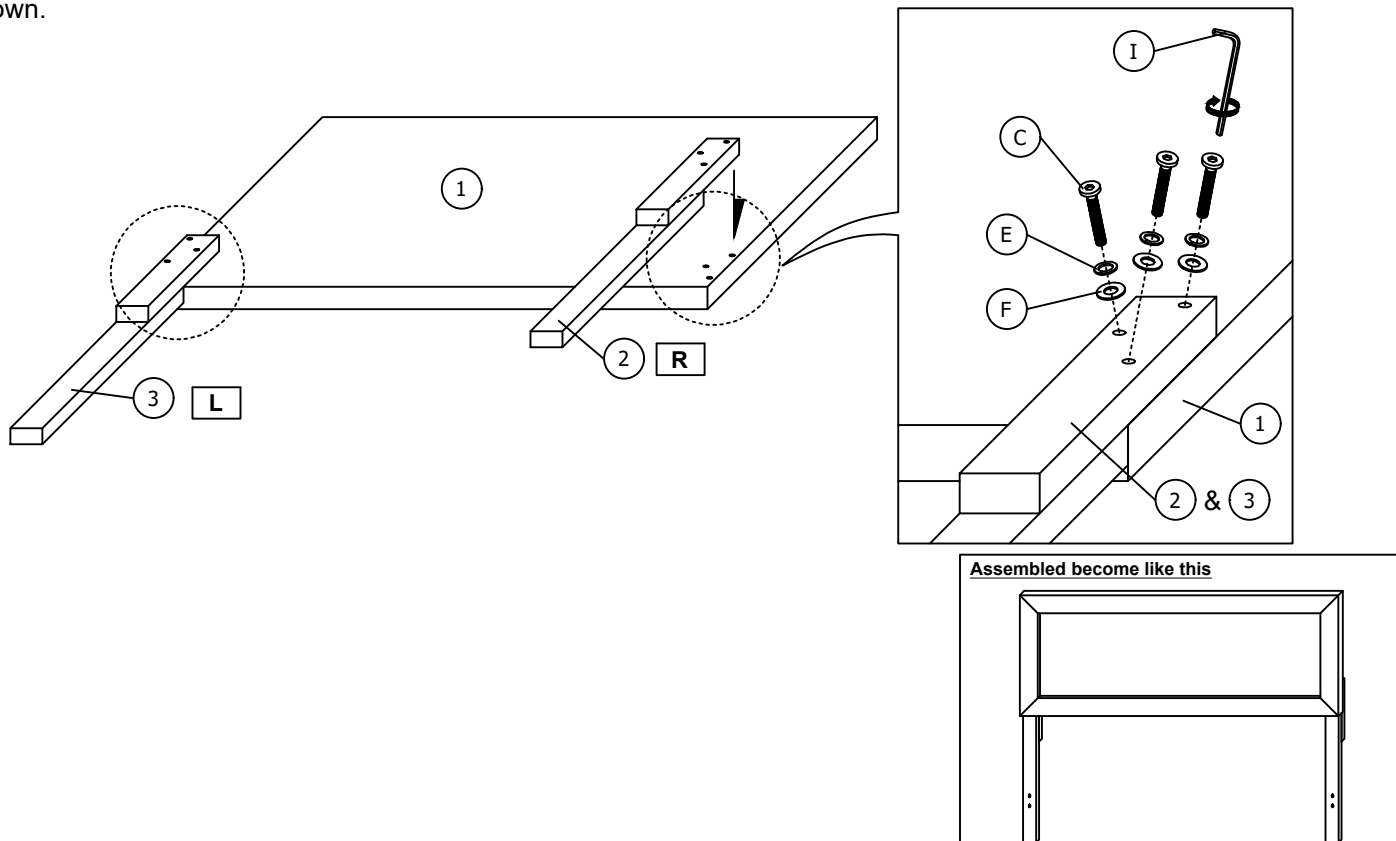

ASSEMBLY INSTRUCTION

STEP 3

Align the position of hole then put 1 piece SIDE RAIL SUPPORT RAIL(9) on 1 piece SIDE RAIL(i) and (ii)-(5) and (6). Insert 4 pieces JCBB SCREW (B), SPRING WASHER(E) and FLAT WHSHER(F) to combine (5),(6) and (9) as shown. This step needs to be **done twice**.

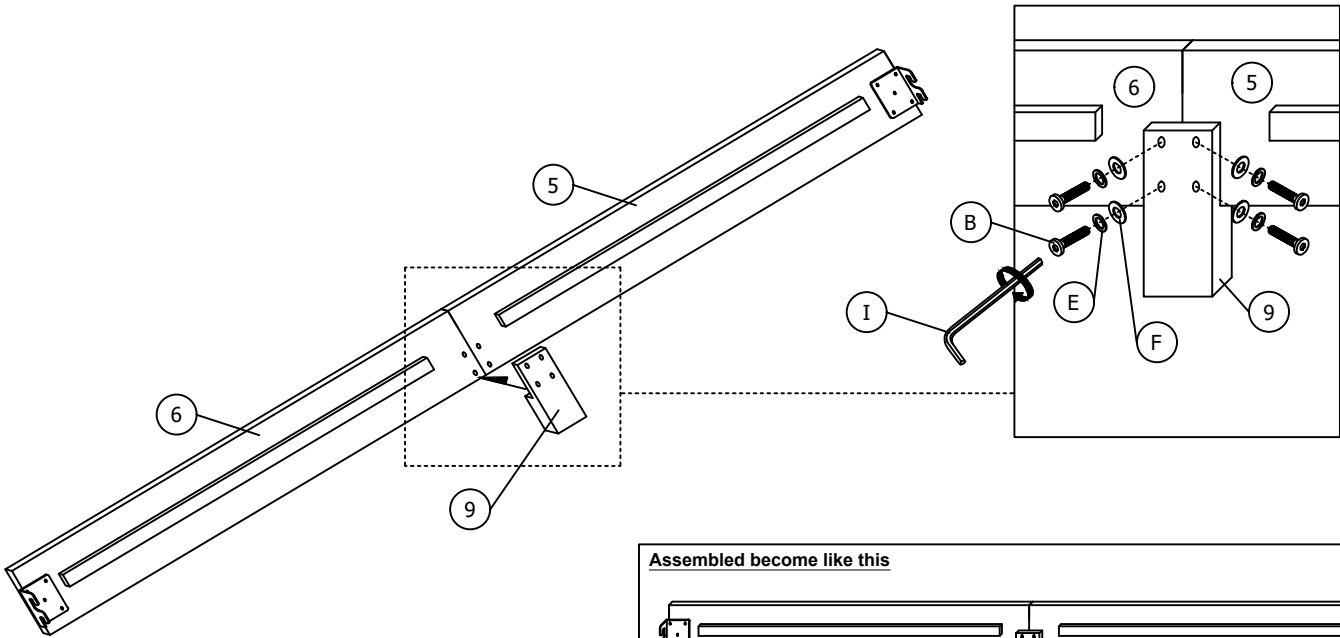

STEP 4

Insert the 8 pieces JCBB SCREW (A) to the HAEDBOARD(1) and the FOOTBOARD (4) , then combine the SIDE RAILS(i) and (ii)-(5) and (6) to (1) and (4) as shown.

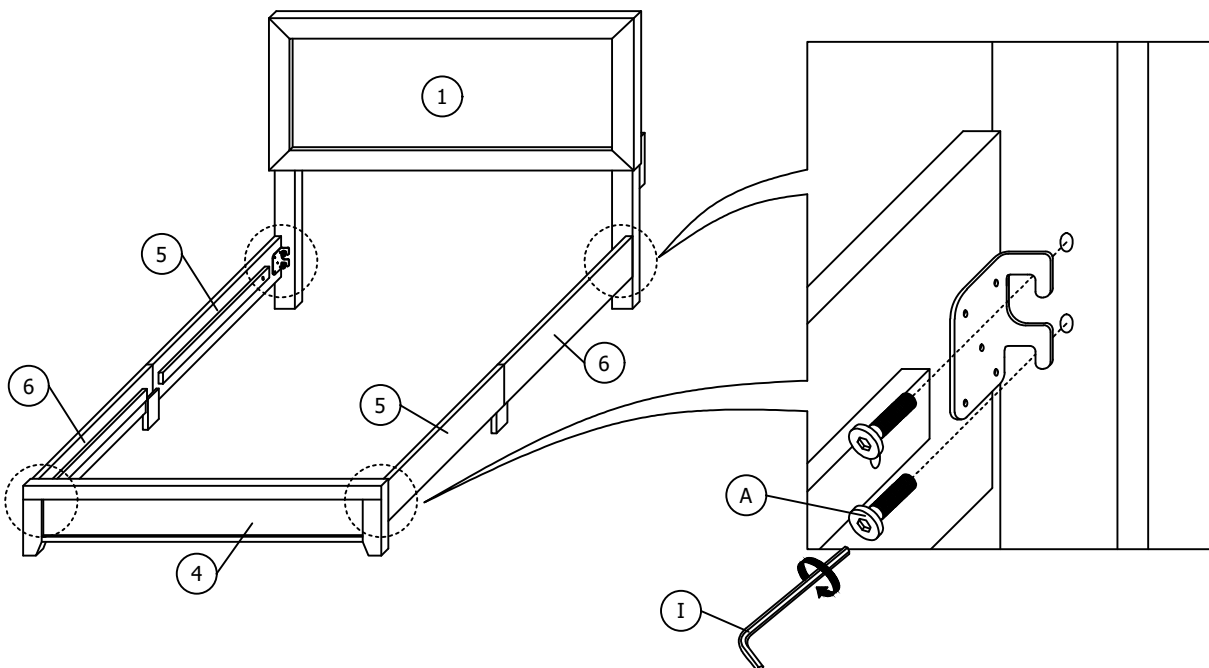

ASSEMBLY INSTRUCTION

STEP 5

Put the 4 pieces SLAT (7)-(combined with CENTRE SUPPORT LEG(8) in step 1) on the wood of SIDE RAILS(i) and (ii)-(5) and (6).Then insert 8 pieces CSK C/B SCREW (G) to fix as shown.

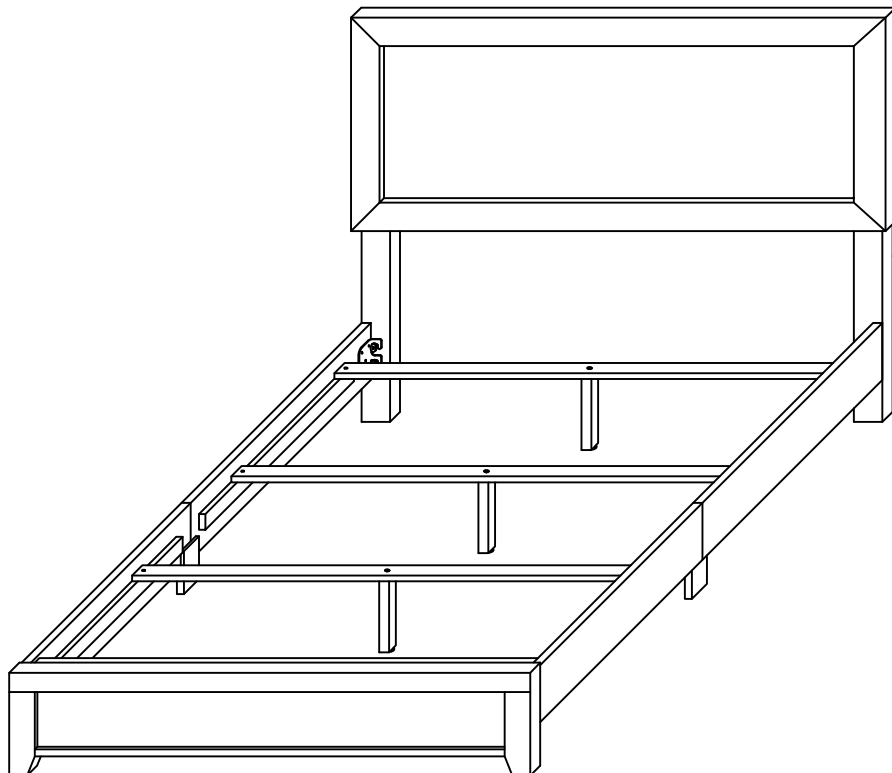
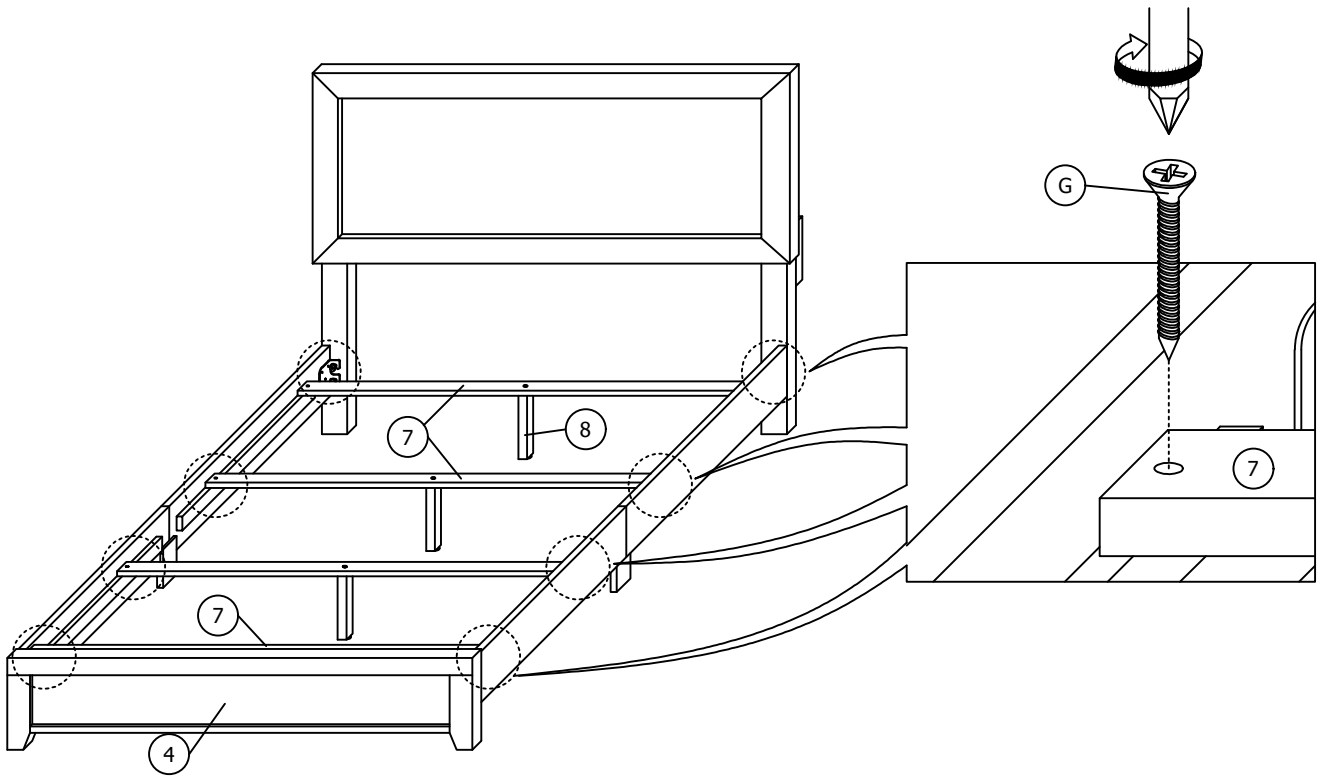

ASSEMBLY COMPLETED