

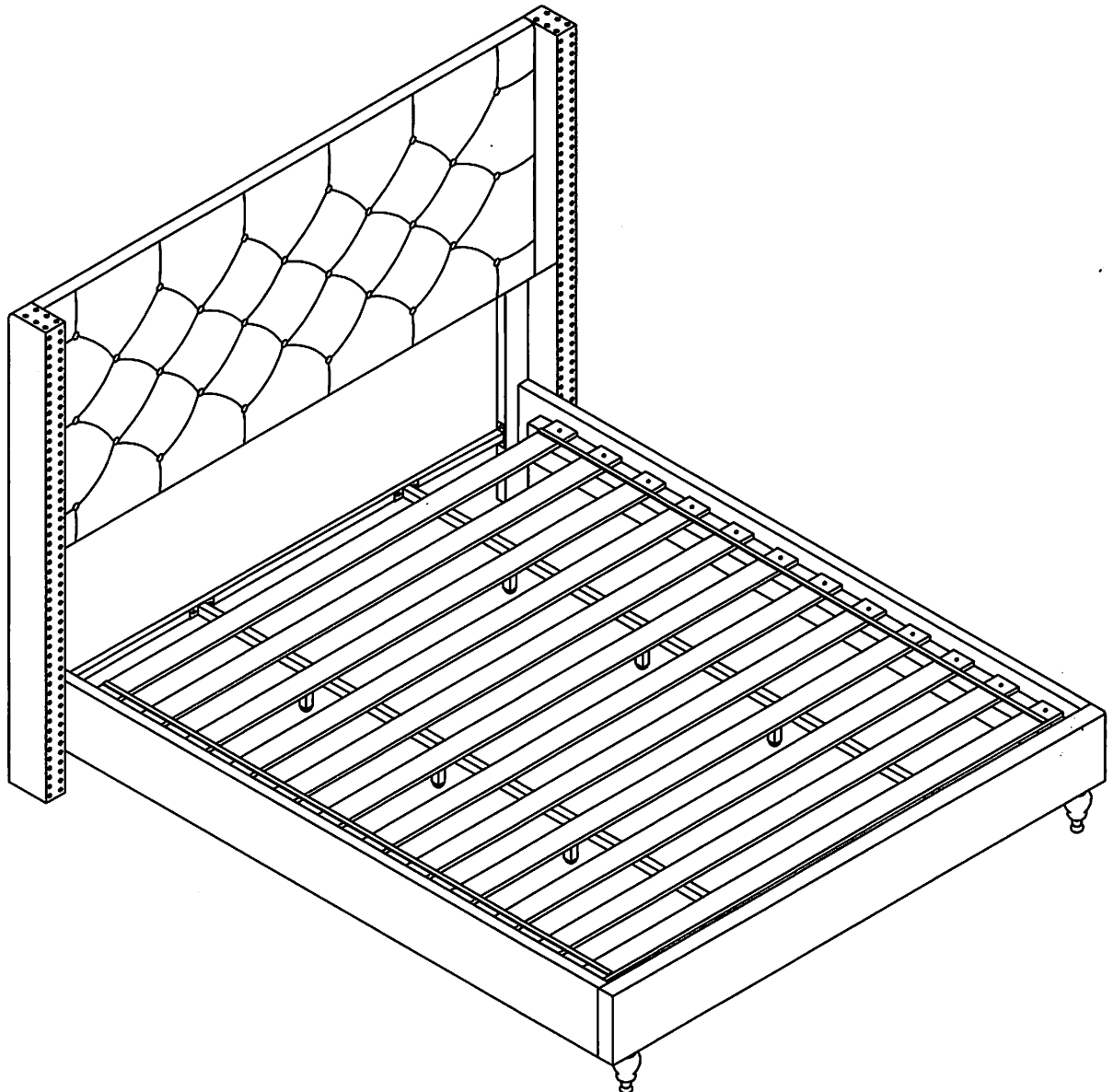

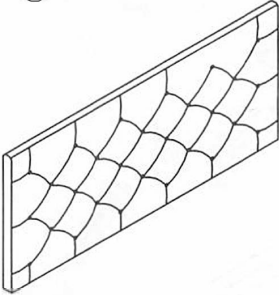

ASSEMBLY INSTRUCTION

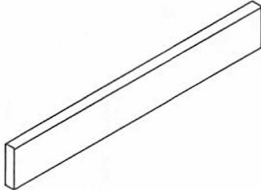

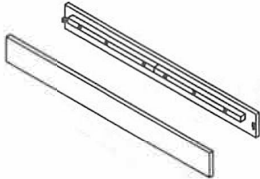
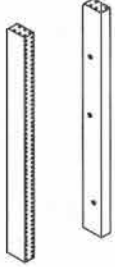

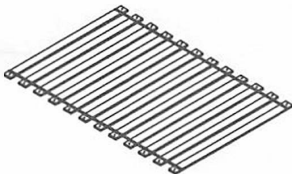
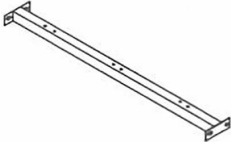

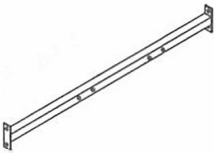

IMPORTANT: PLACE ALL PARTS ON A CLEAN AND SMOOTH SURFACE SUCH AS A RUG OR CARPET TO AVOID THE PARTS FROM BEING SCRATCHED
KINDLY FOLLOW THE ASSEMBLY INSTRUCTIONS STEP
DO NOT TIGHTEN ALL SCREWS UNTIL THE BED IS FULLY SET-UP



PARTS LIST:

<p>① Headboard=1pc</p> 	<p>② Footboard=1pcs</p> 	<p>③ Side Rail=2pcs</p> 	<p>④ Wingback=2pcs</p> 
<p>⑤ HB Leg=2pcs</p> 	<p>⑥ FB Feet=2pcs</p> 	<p>⑦ Slats=12pcs</p> 	<p>⑧ Support rails=2pcs</p> 
<p>⑨ Support leg=6pcs</p> 	<p>⑩ Crossband=1pc</p> 		

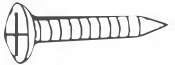
HARDWARE LIST:

<p>A Allen Key=1pc</p> 	<p>B Bolt $\frac{5}{16}$"x1-1/2"=16pcs</p> 	<p>C Bolt $\frac{5}{16}$"x2"=24pcs</p> 	<p>D Bolt $\frac{5}{16}$"x4"=2pcs</p> 
<p>E Flat Washer $\frac{5}{16}$"x19=72pcs</p> 	<p>F Flat Washer $\frac{5}{16}$"x22=10pcs</p> 	<p>G Spring Washer=30pcs</p> 	<p>H screw 10mmx1-1/4"=24pcs</p> 
<p>I Nut=16pcs</p> 	<p>J Wrench=1pc</p> 		

BOX 1/2 CONTENTS

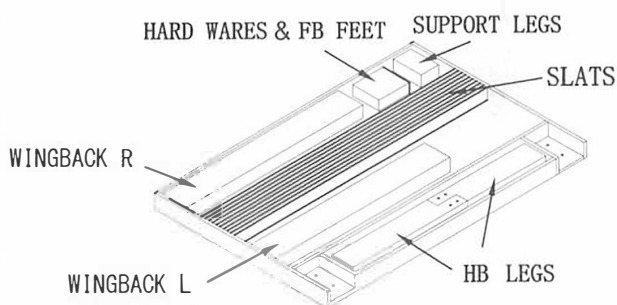

Parts ④⑤⑥⑦⑨ Hidden at the back of the Headboard, plz lift the cover.

BOX 2/2 CONTENTS

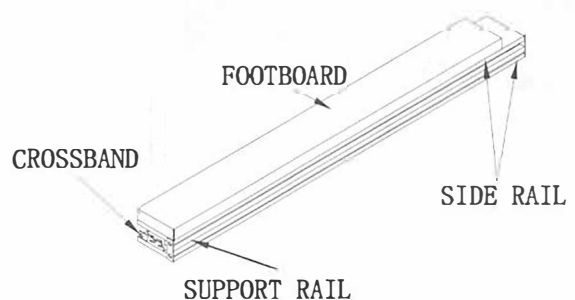

STEP 1

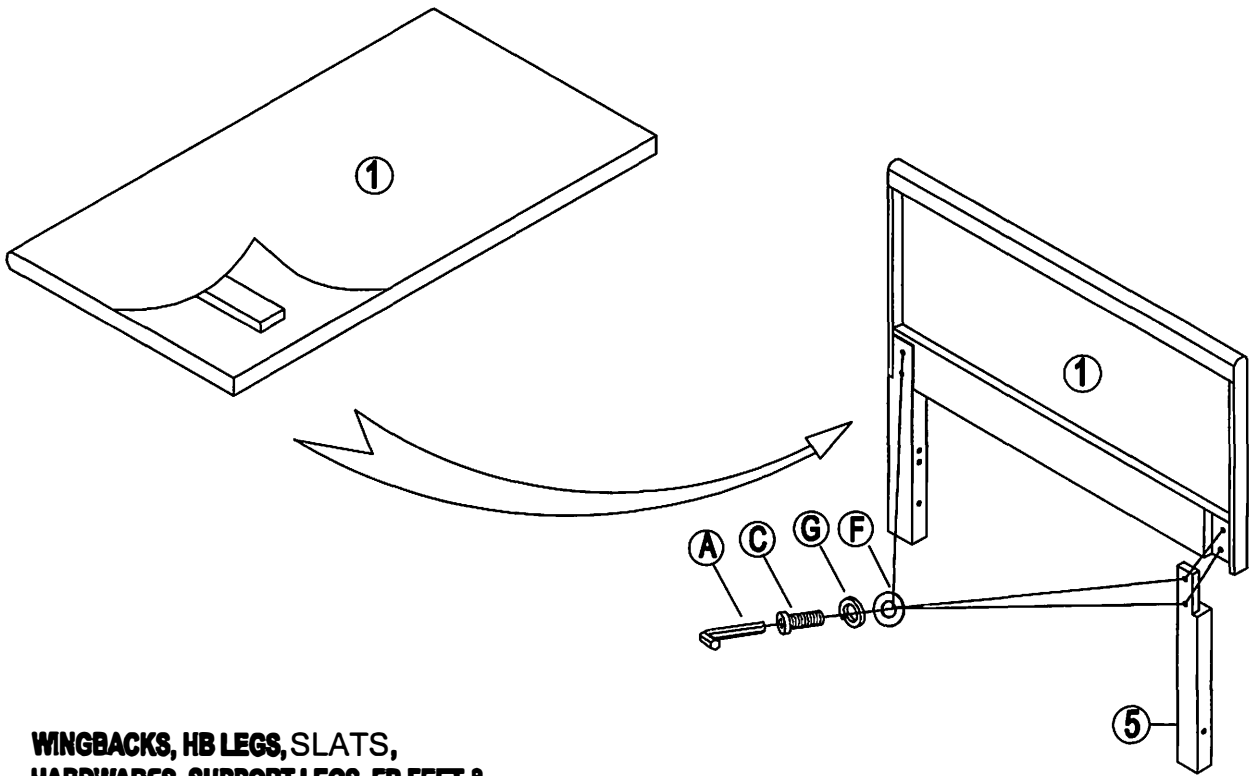

**WINGBACKS, HB LEGS, SLATS,
HARDWARES, SUPPORT LEGS, FB FEET &
ASSEMBLE INSTRUCTION HIDDEN INSIDE OF
THE HEADBOARD, PLZ LIFT THE COVER .**

STEP 2

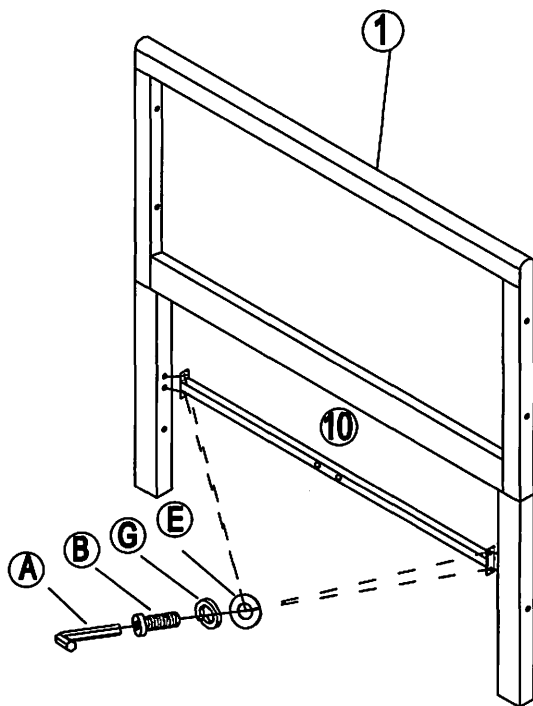

STEP 3

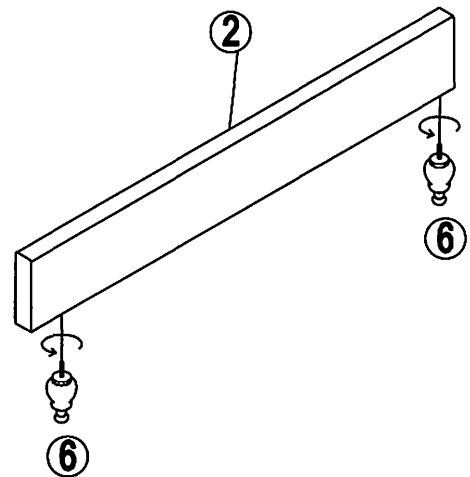

STEP 4

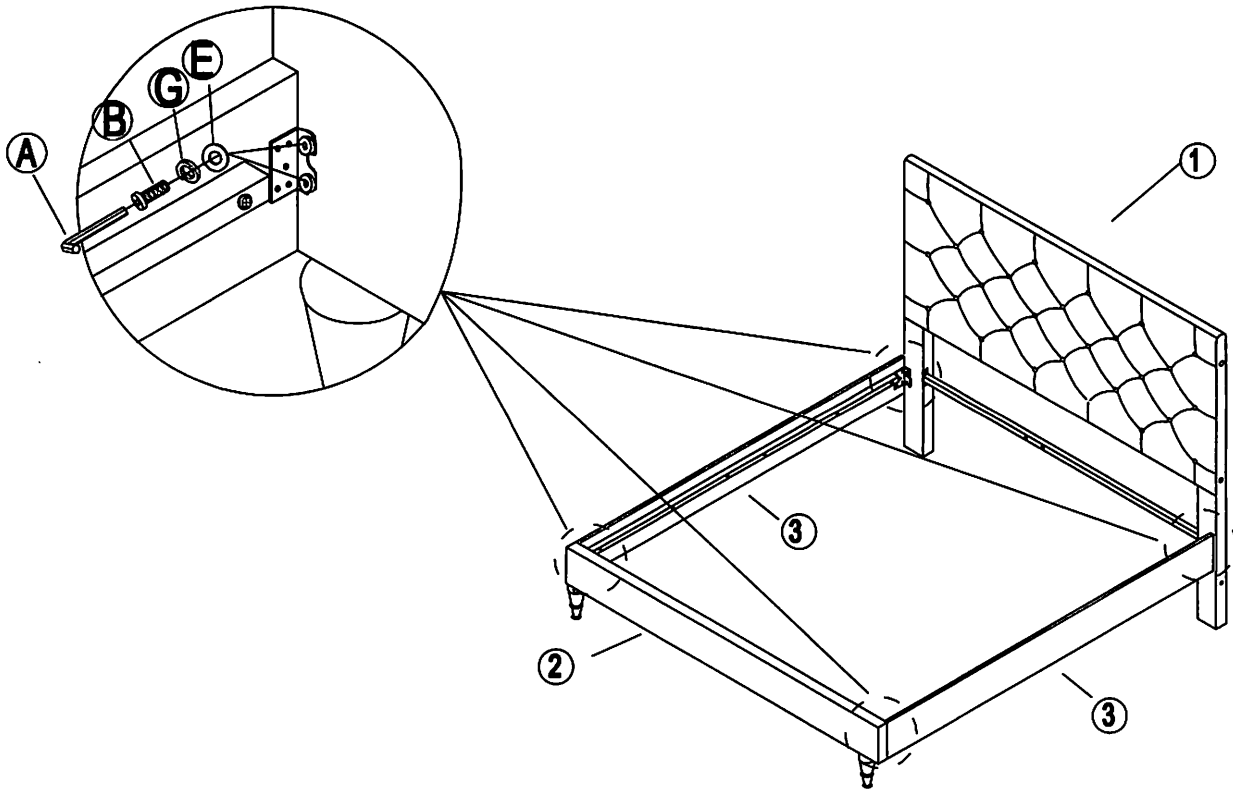

STEP 5

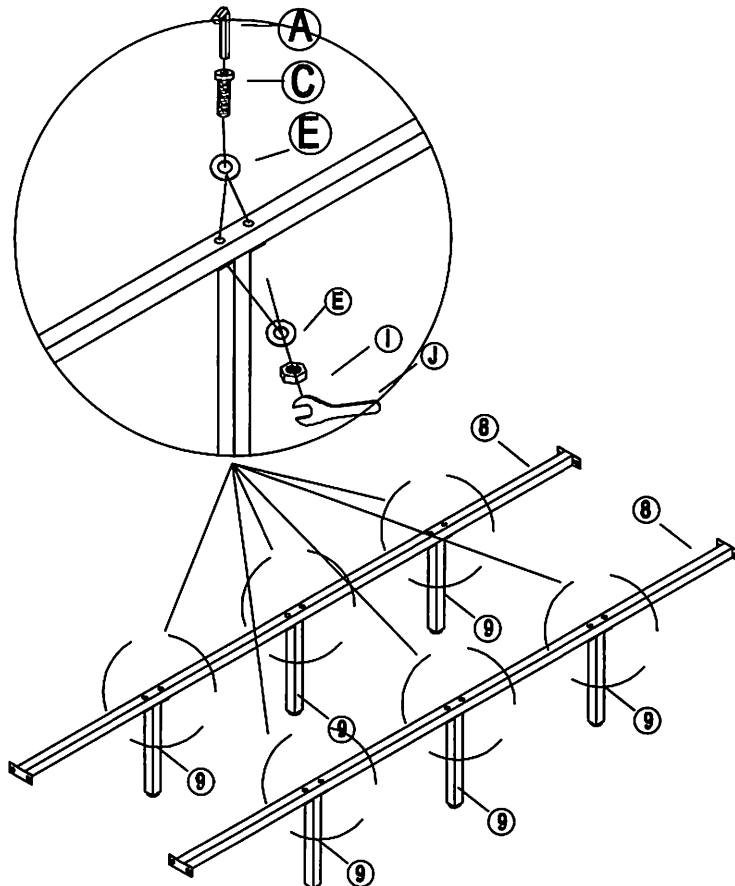

STEP 6

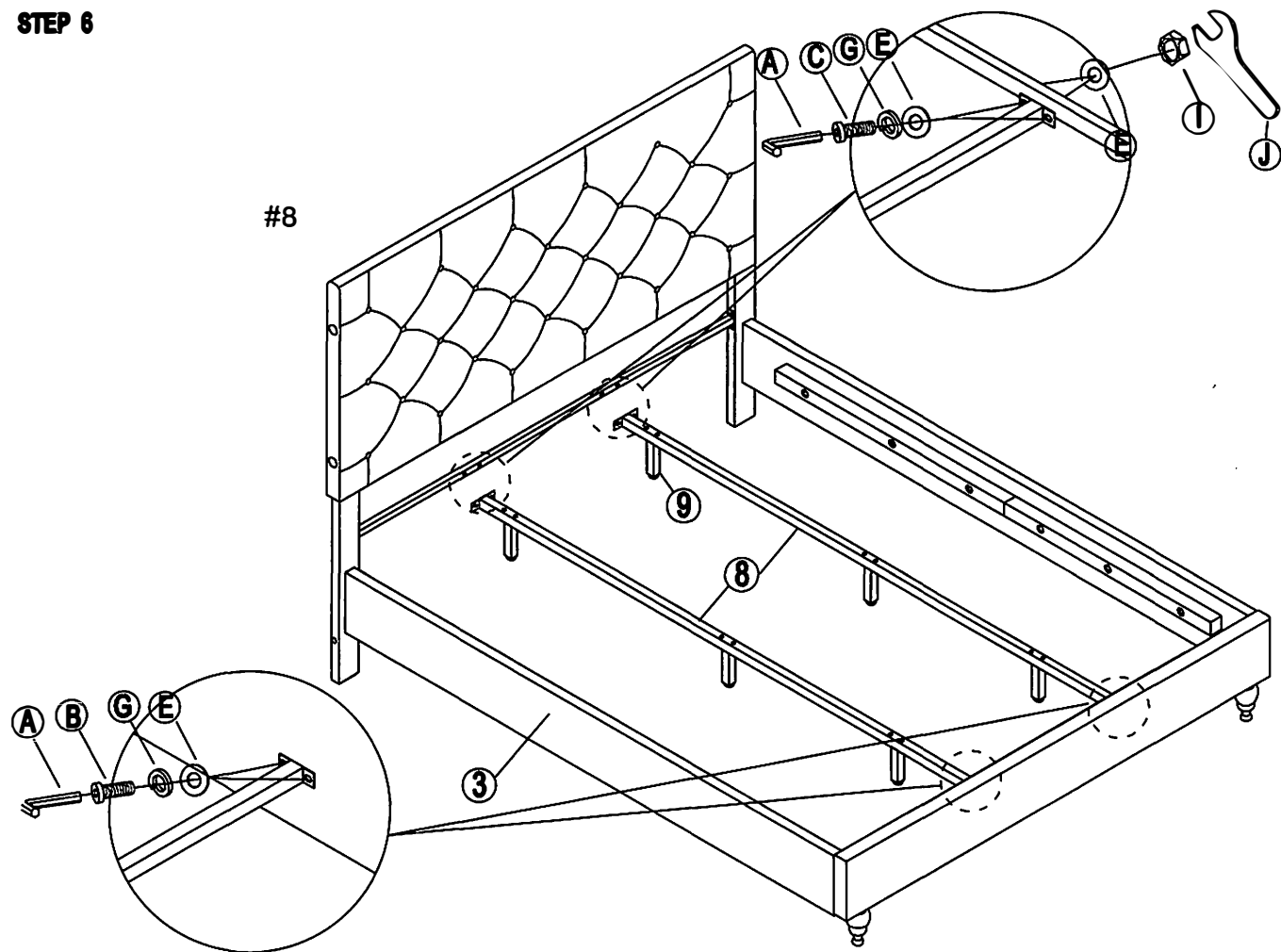

STEP 7

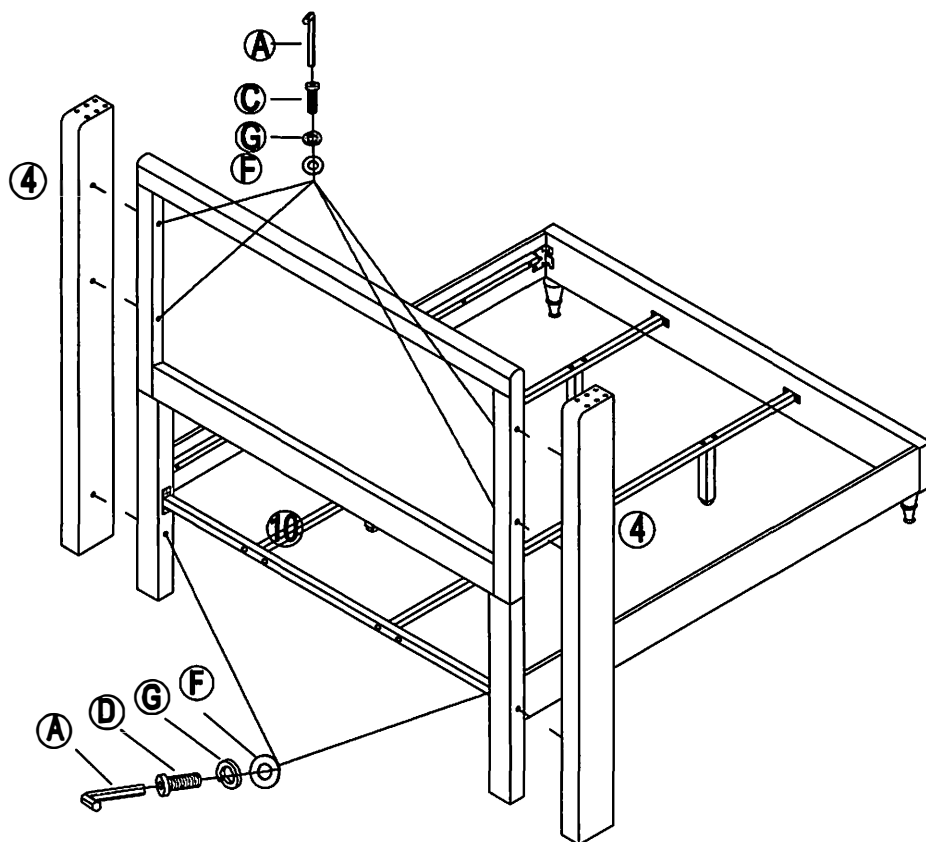

STEP 8

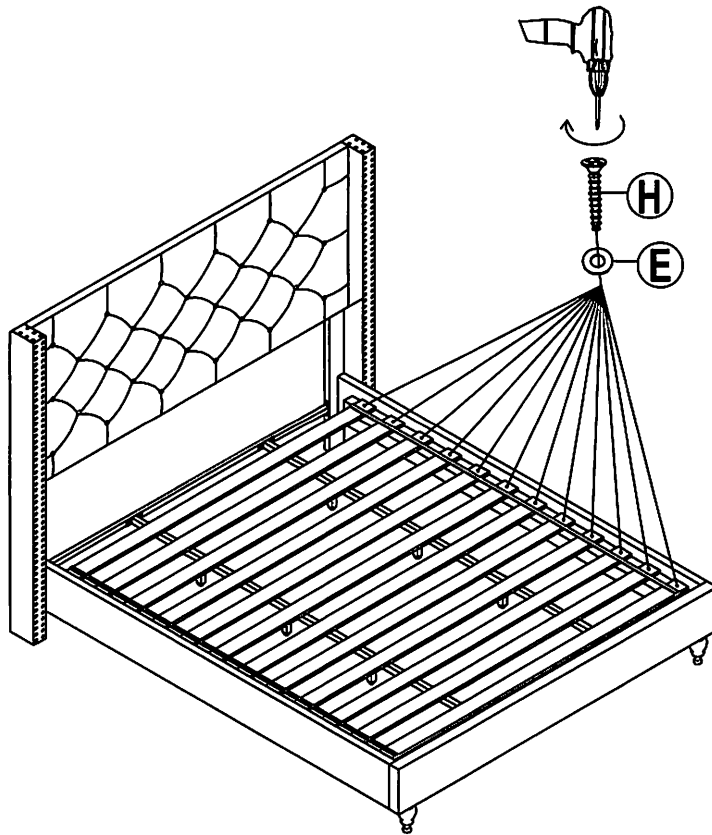

STEP 9

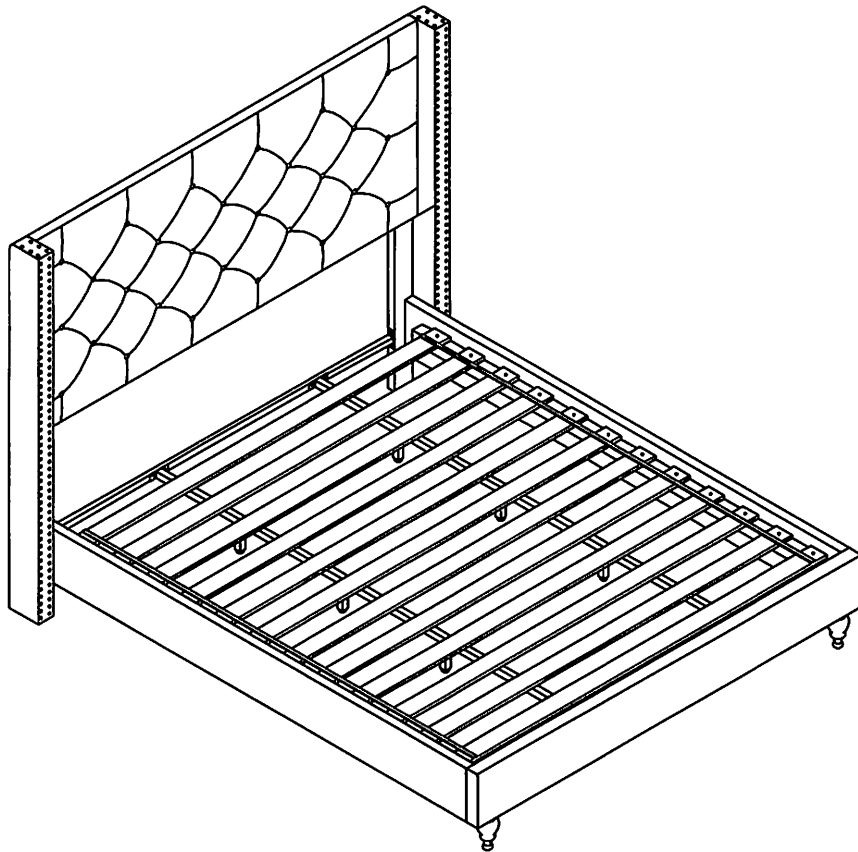

FINAL