

Assembly Instructions

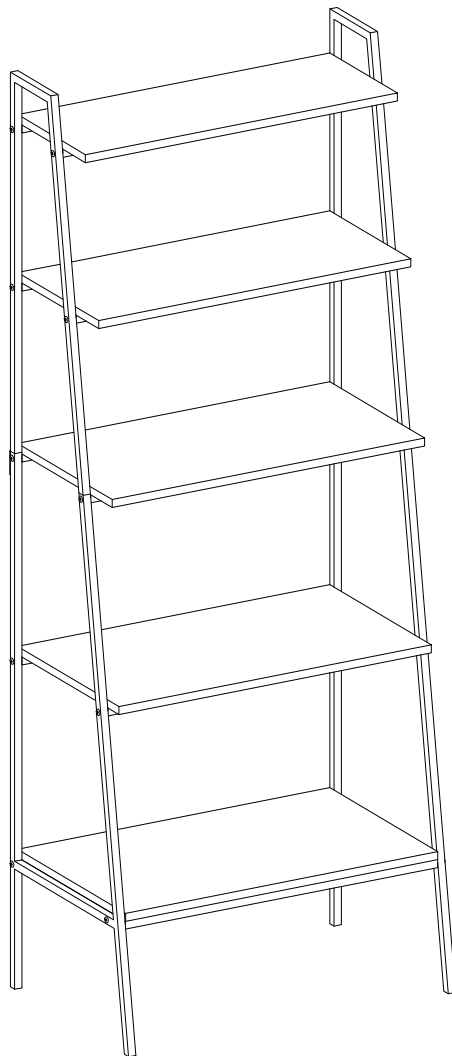

General Assembly Guidelines

- I. Ensure that all parts and hardware are available before beginning assembly.
- II. Follow each step carefully to ensure the proper assembly of this product.
- III. Two people are recommended for ease in the assembly of this product.
- IV. The main type of hardware used to assemble this product are: bolts and screws.
- V. Power tools should not be used to assemble this product.

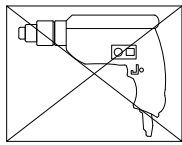





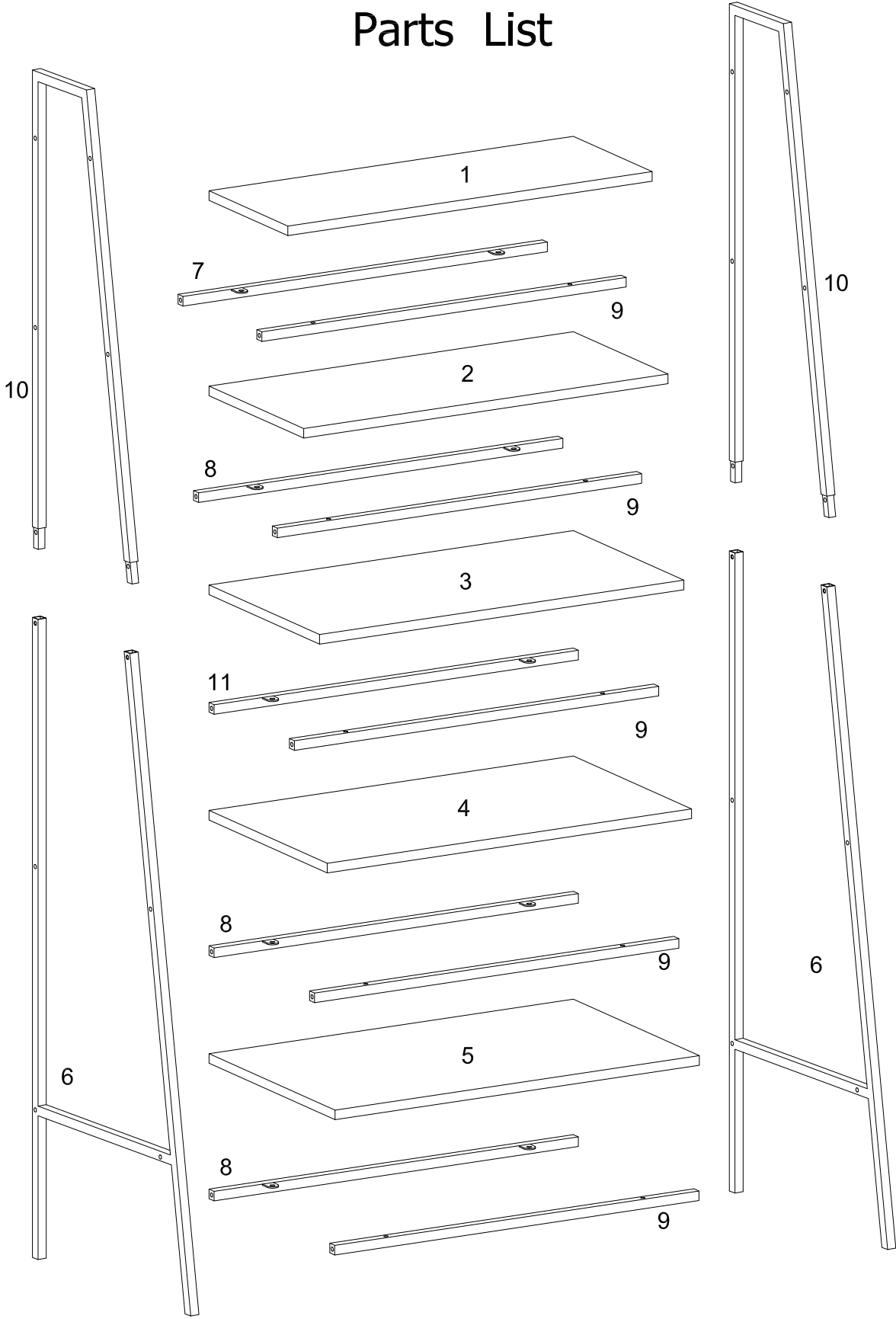

- VI. Drill may be needed for securing product to wall.

Parts List

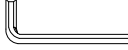

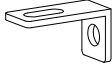
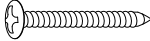
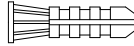
Hardware List

A		Ø1/4"x12mm	Bolt	11 pcs
B		Ø1/4"x25mm	Bolt	30 pcs
C		4 mm	Hex Key	1 pcs
D		Ø16x6.5x1.0mm	Washer	1 pcs
E		40x25x20mm	Bracket	1 pcs
F		Ø4x30mm	Screw	1 pcs
G			Wall anchor	1 pcs
H			Coner plate	2 pcs
J		Ø4x12mm	Screw	4 pcs

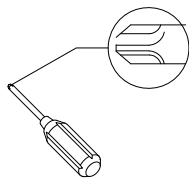

Philips head screwdriver required for assembly
(not included)

*The hardware quantities listed above are required for proper assembly.
Some extra hardware may also have been included.*

Step 1

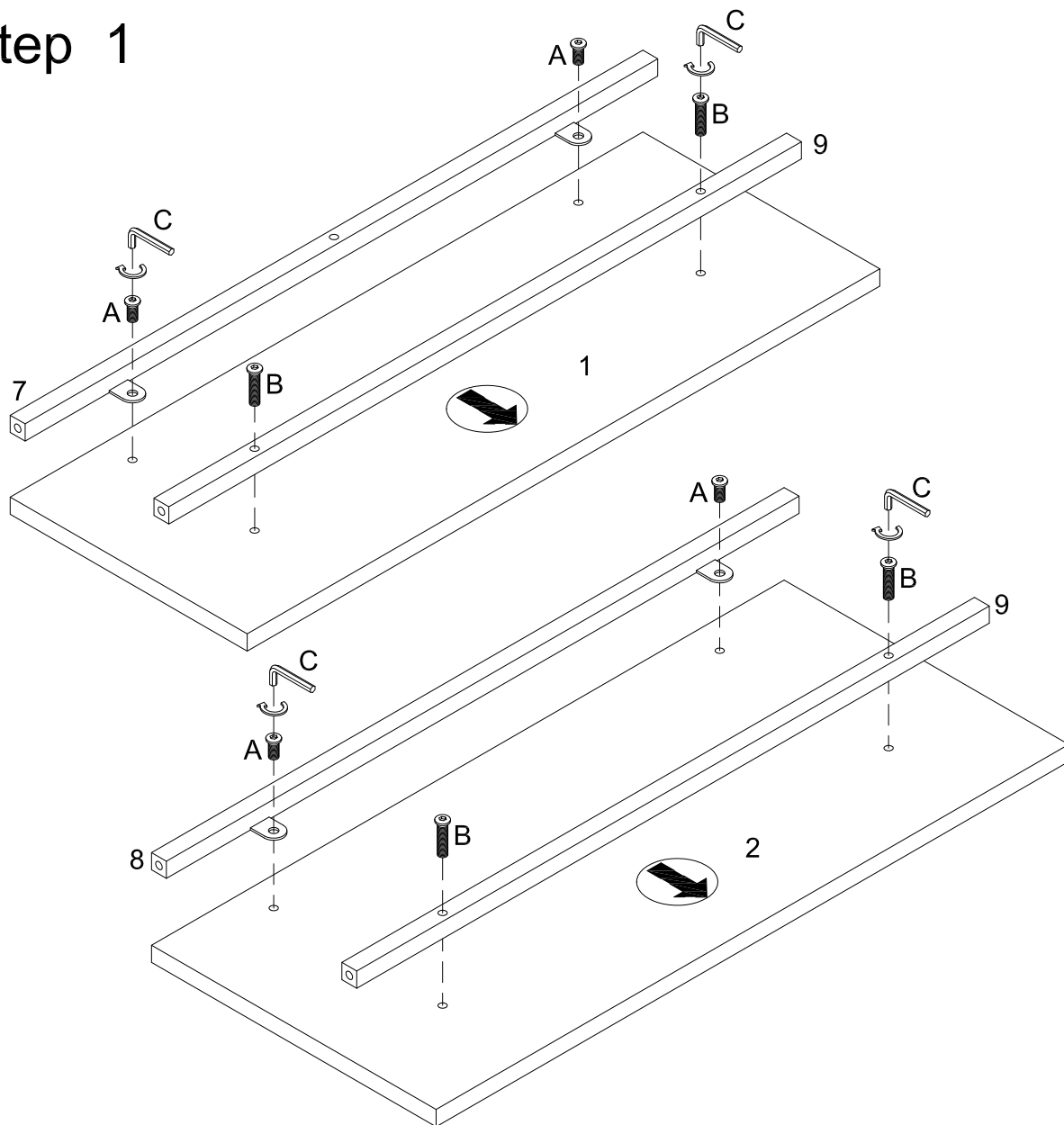

Attach part (7,9) to part (1), part (8,9) to part (2) using bolt (A,B) with hex key (C).

Step 2

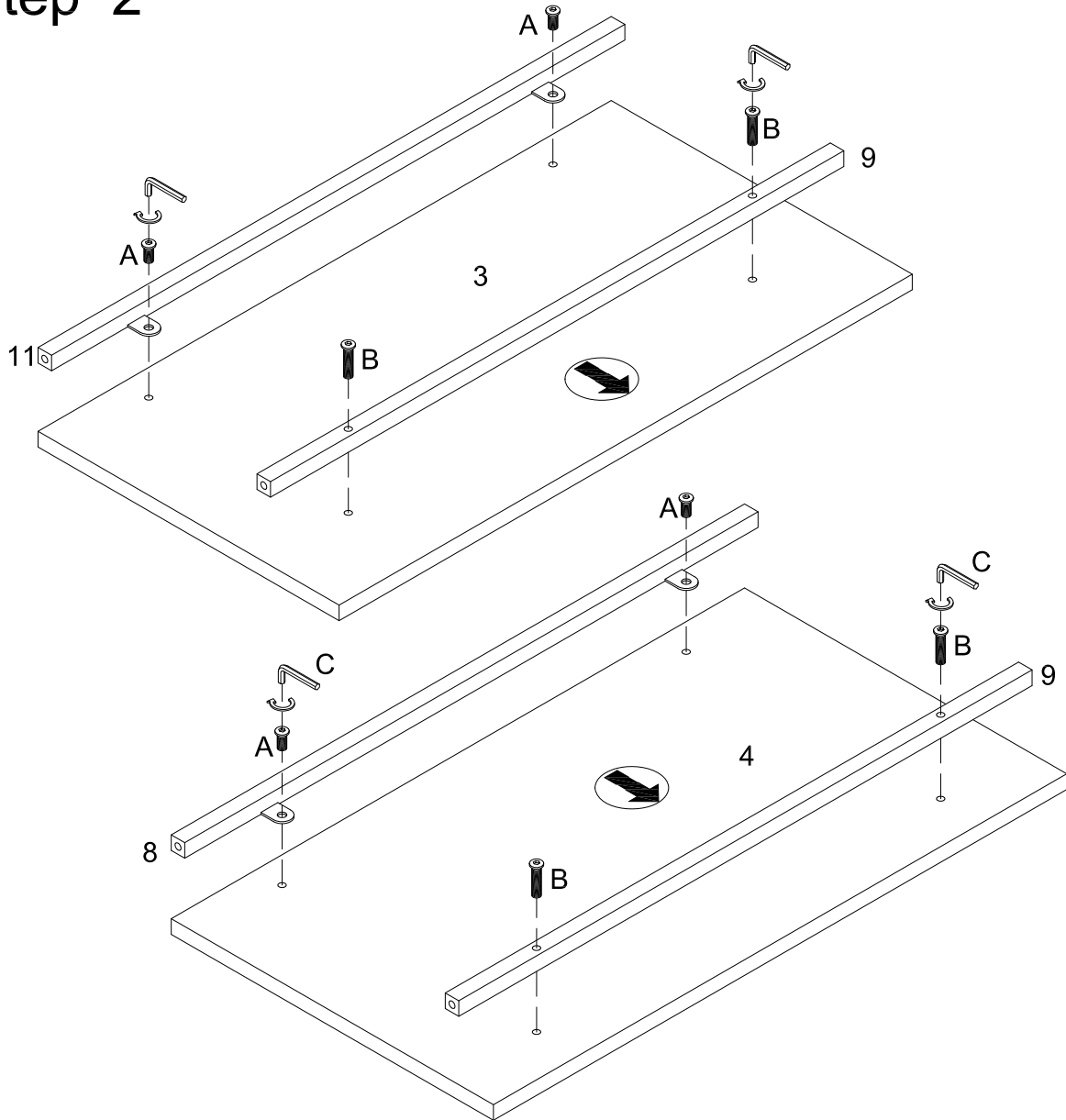

Attach part (11,9) to part (3), part (8,9) to part (4) using bolt (A,B) with hex key (C).

Step 3

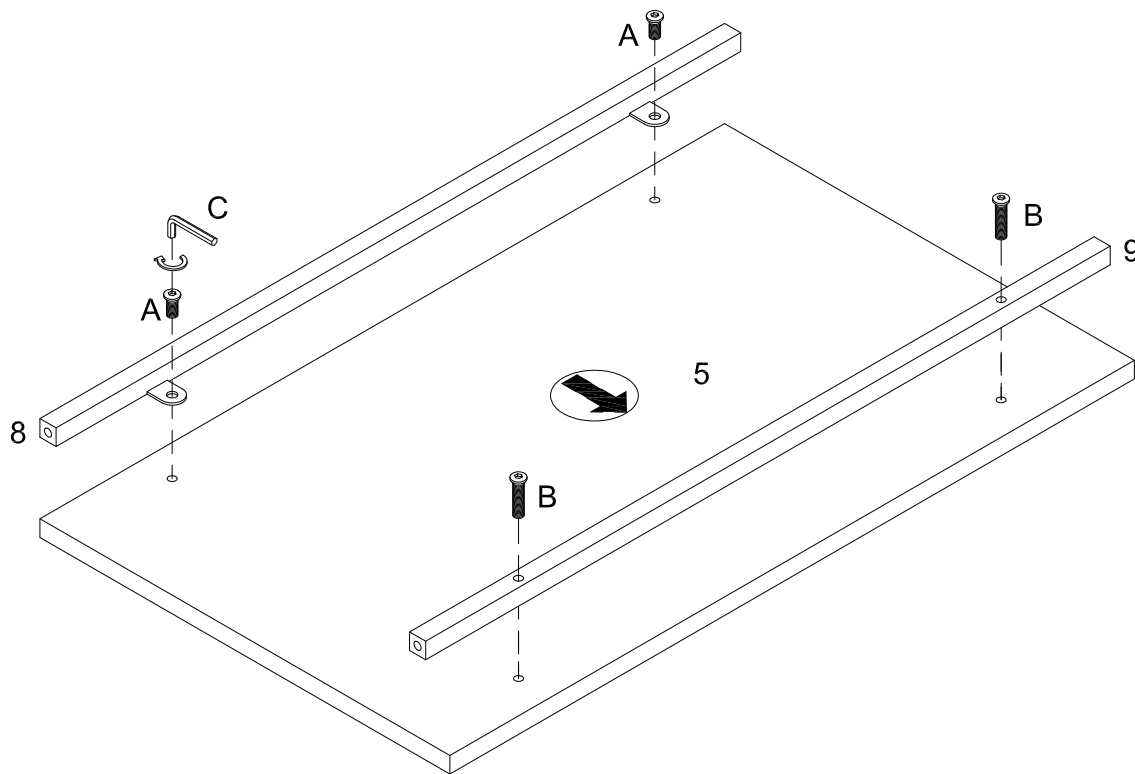

Attach part (8,9) to part (5) using bolt (A,B) with hex key (C).

Step 4

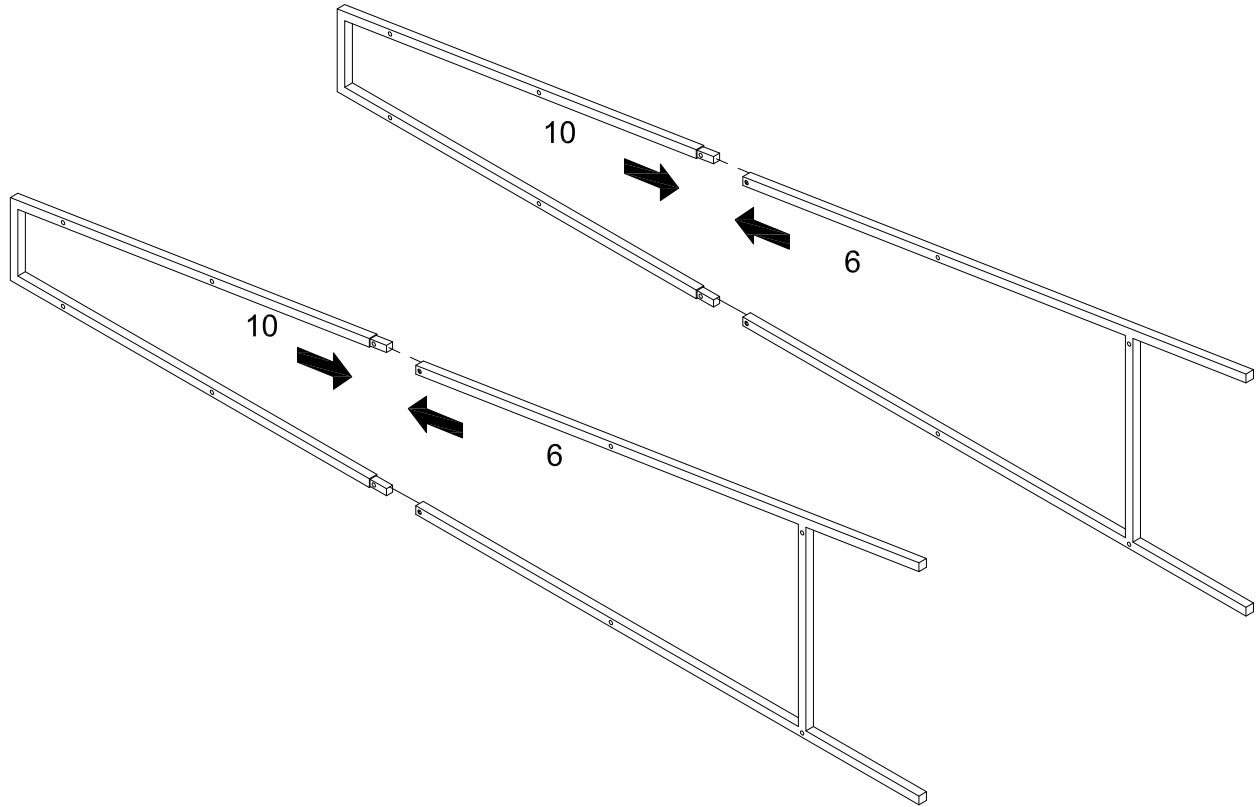

Attach part (10) to part (6) as per diagram.

Step 5

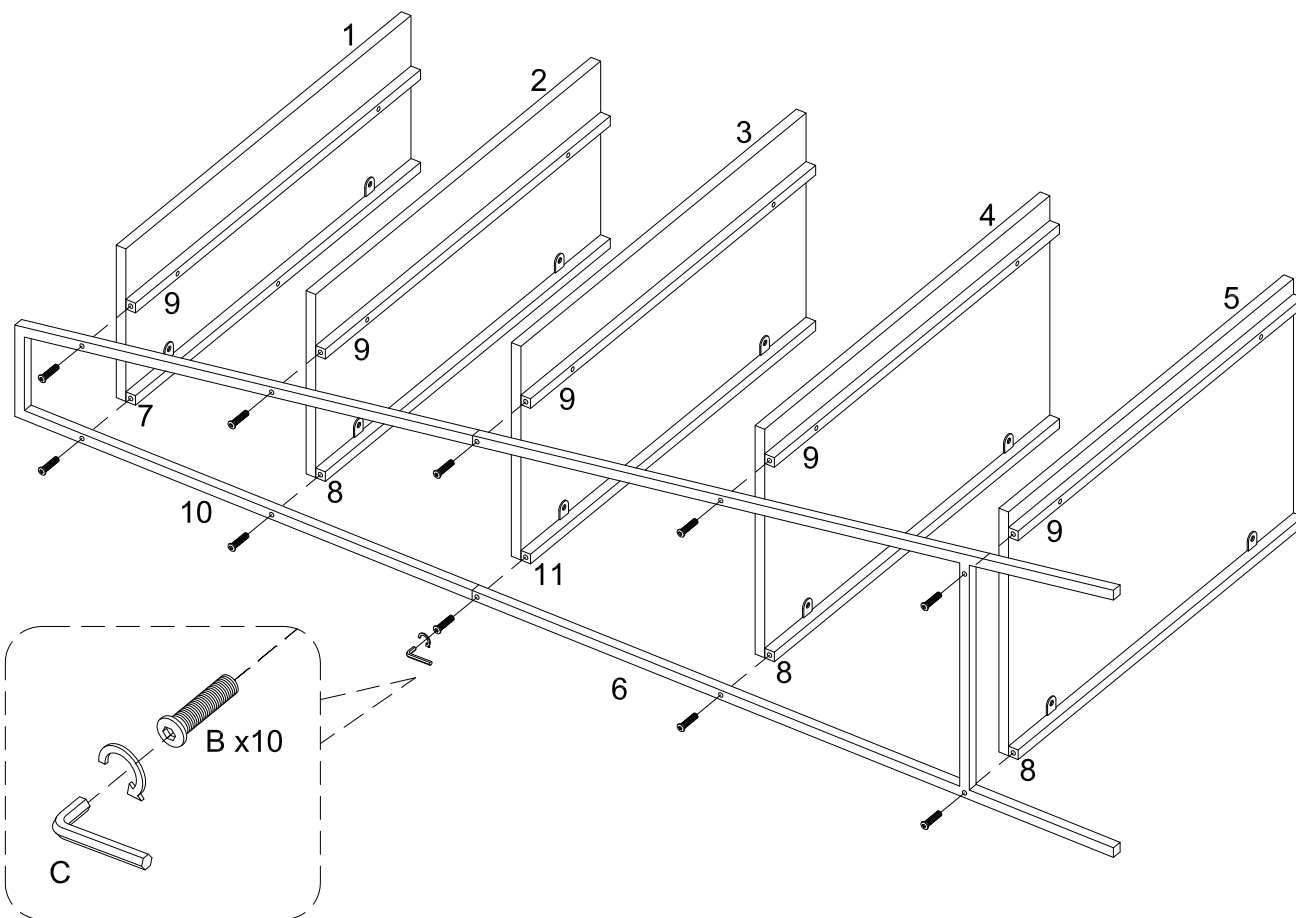

Attach part (6,10) to part (9,7,8,11) using bolt (B) with hex key (C).

Step 6

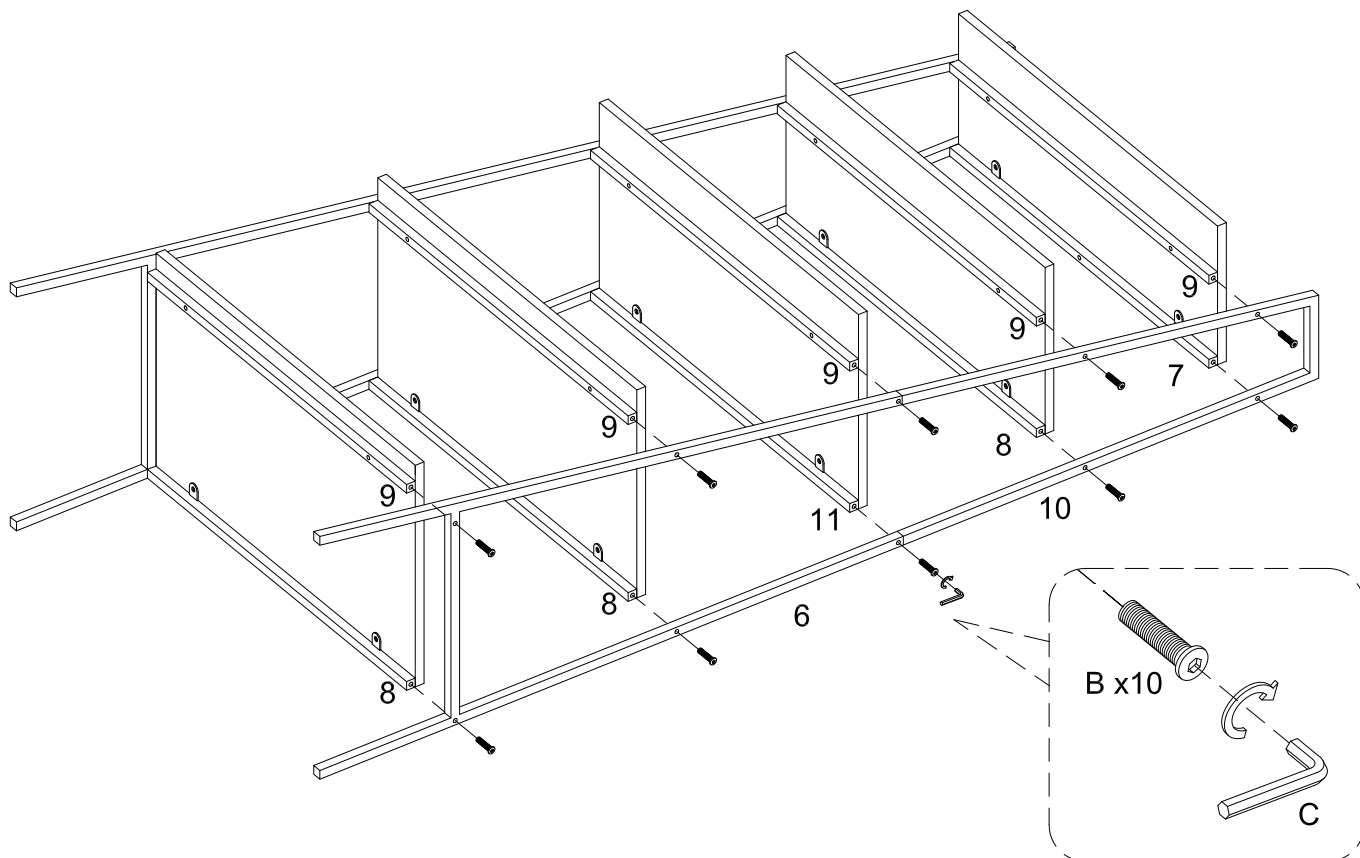

Attach part (6,10) to part (7,8,9,11) using bolt (B) with hex key (C).

Step 7

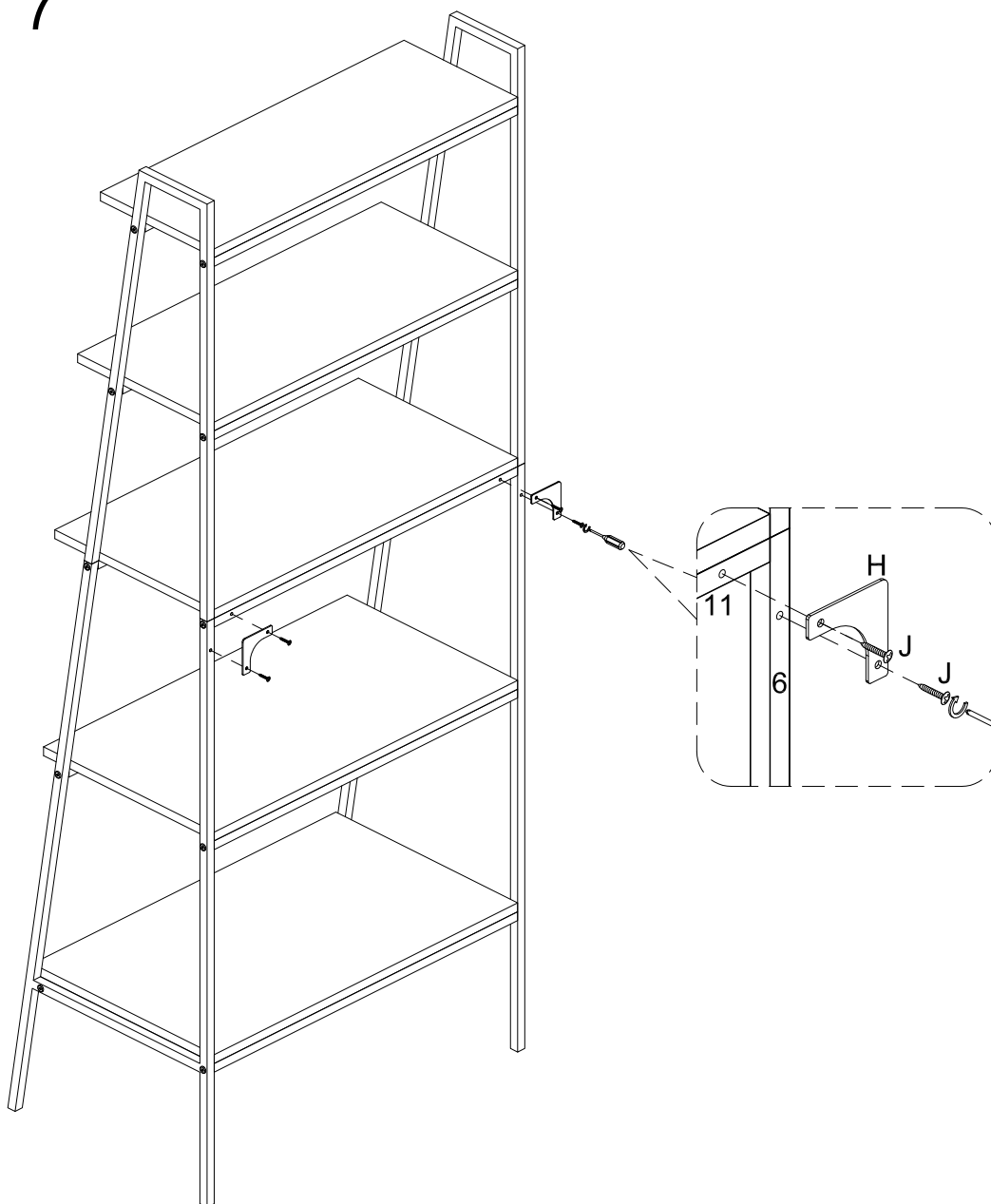

Attach corner plate (H) to part (11) (6) using screw (J) with screwdriver.

Step 8

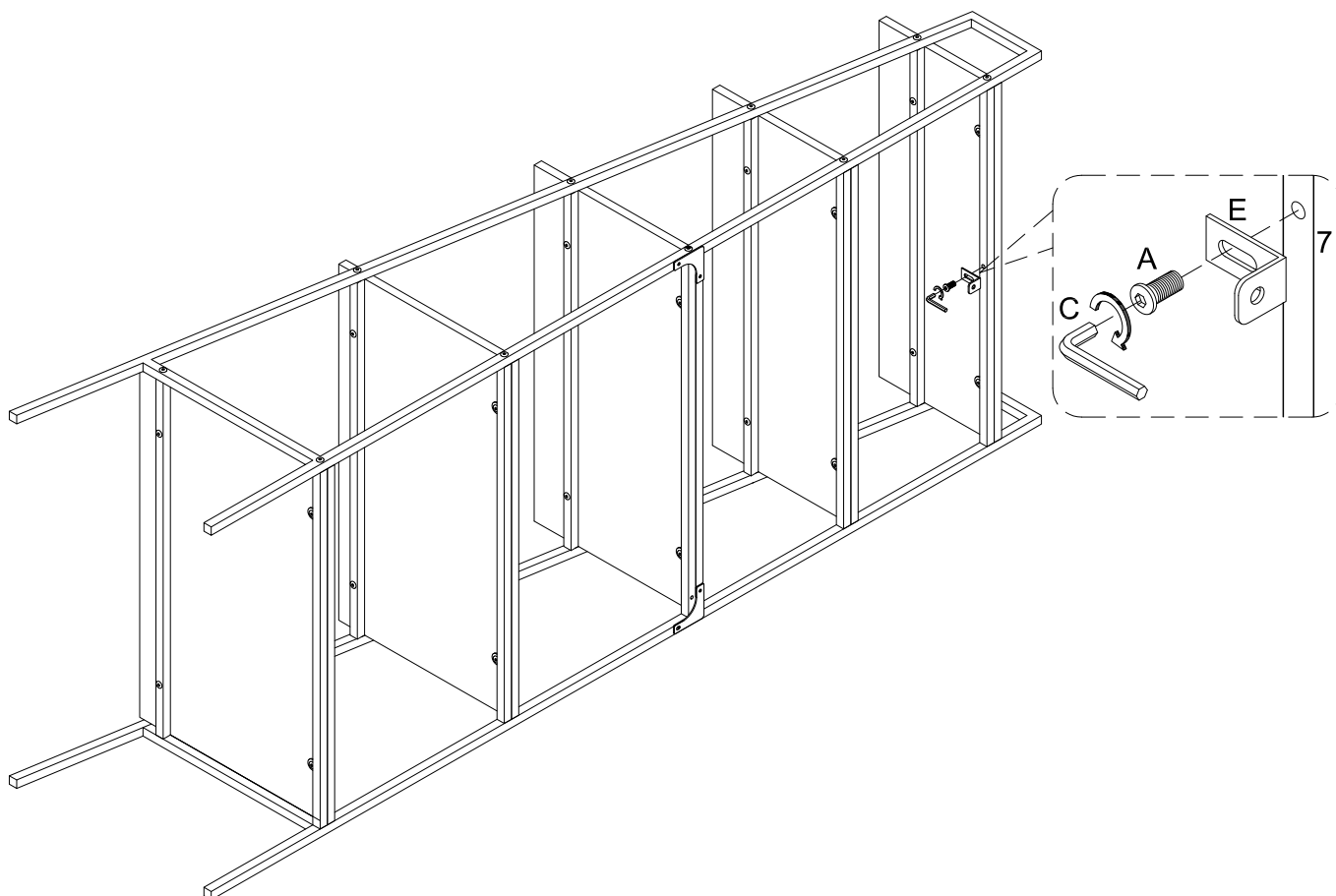

Attach bracket (E) to part (7) using bolt (A) with hex key (C).

Step 9

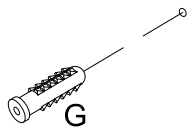
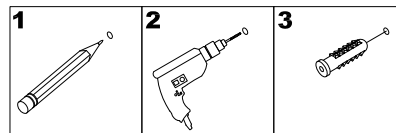

Wall

1. Measure height for bracket in desired location.
2. Drill hole using 6mm size bit.
3. Insert wall anchor (G) into wall at desired location.

*Wall anchor included for drywall mounting. Use correct wall anchor and hardware for your wall material.

Step 10

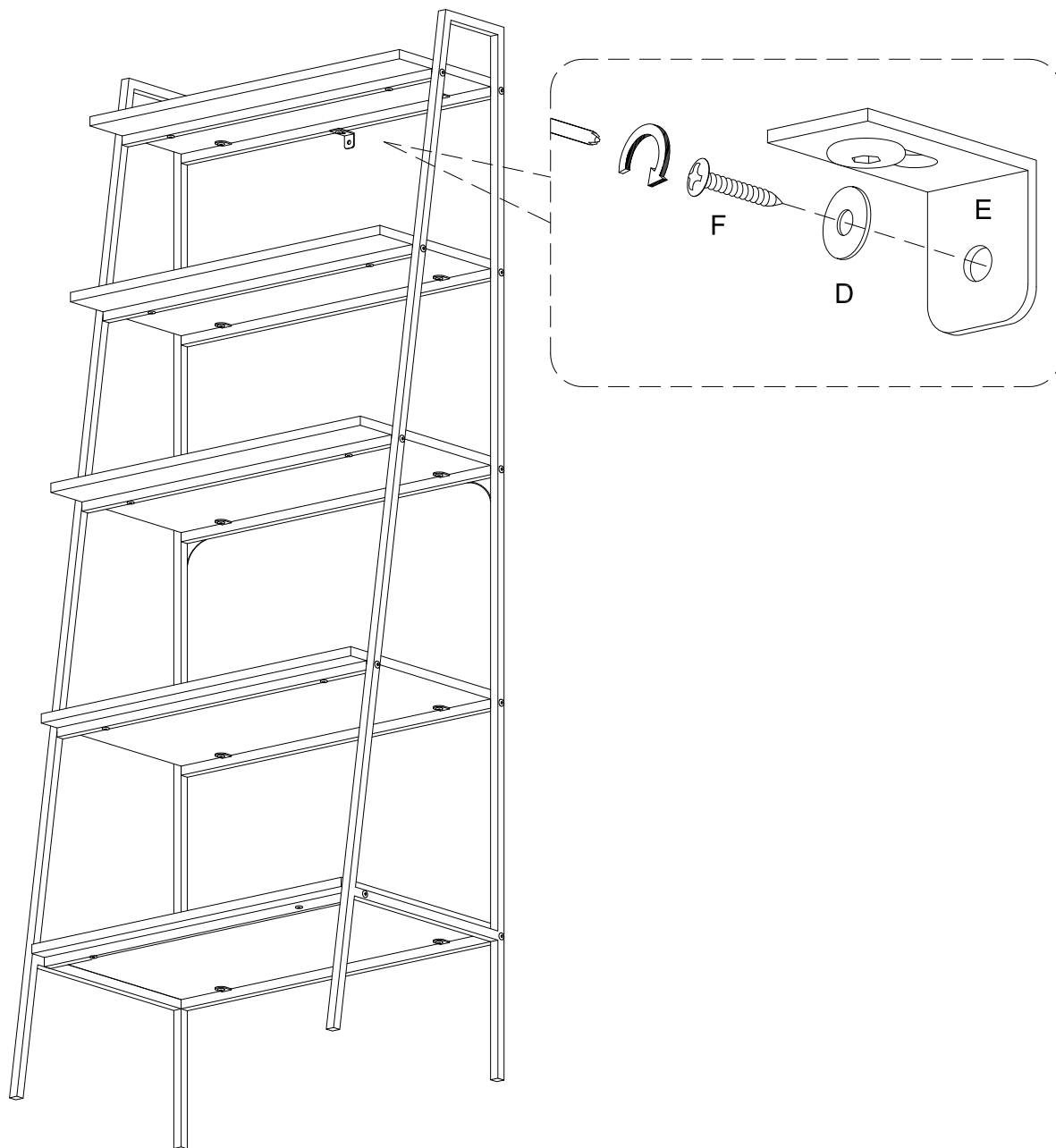

Secure furniture to wall anchor (G) in wall using washer (D) and screw (F) with a screwdriver.

Step 11

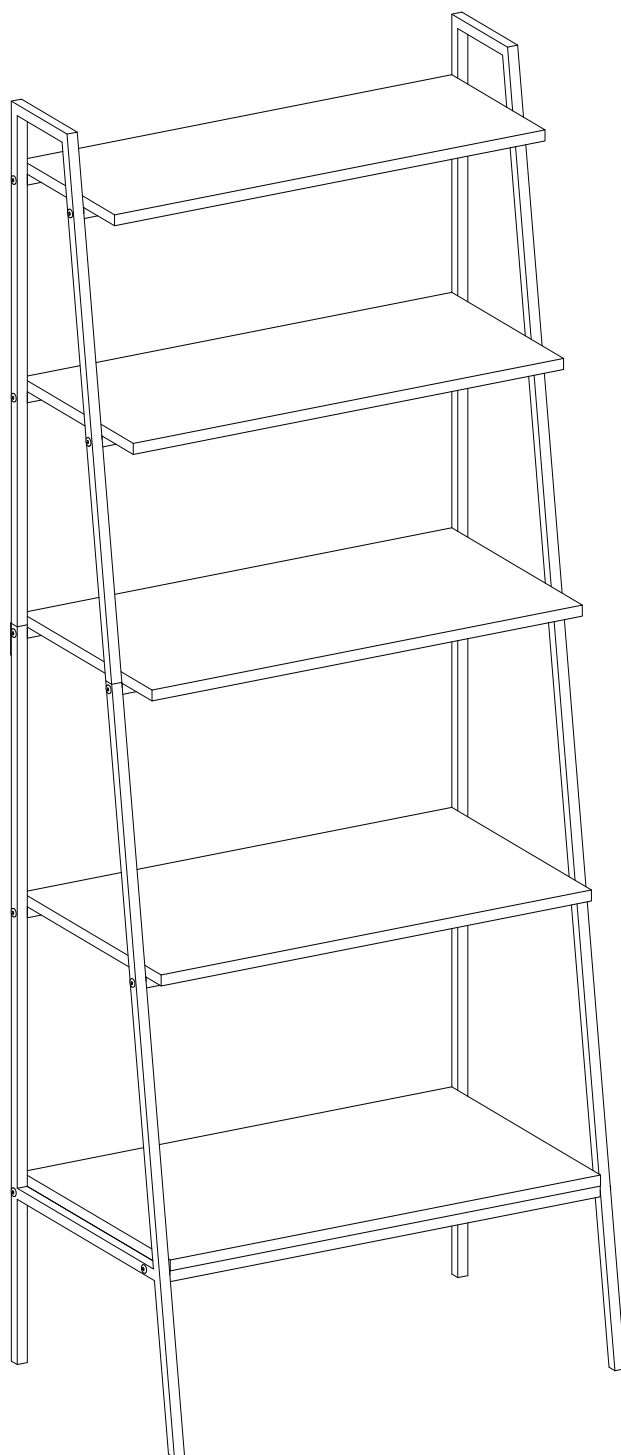

Final Assembly