

ASSEMBLY INSTRUCTIONS

Thank you for purchasing our product.

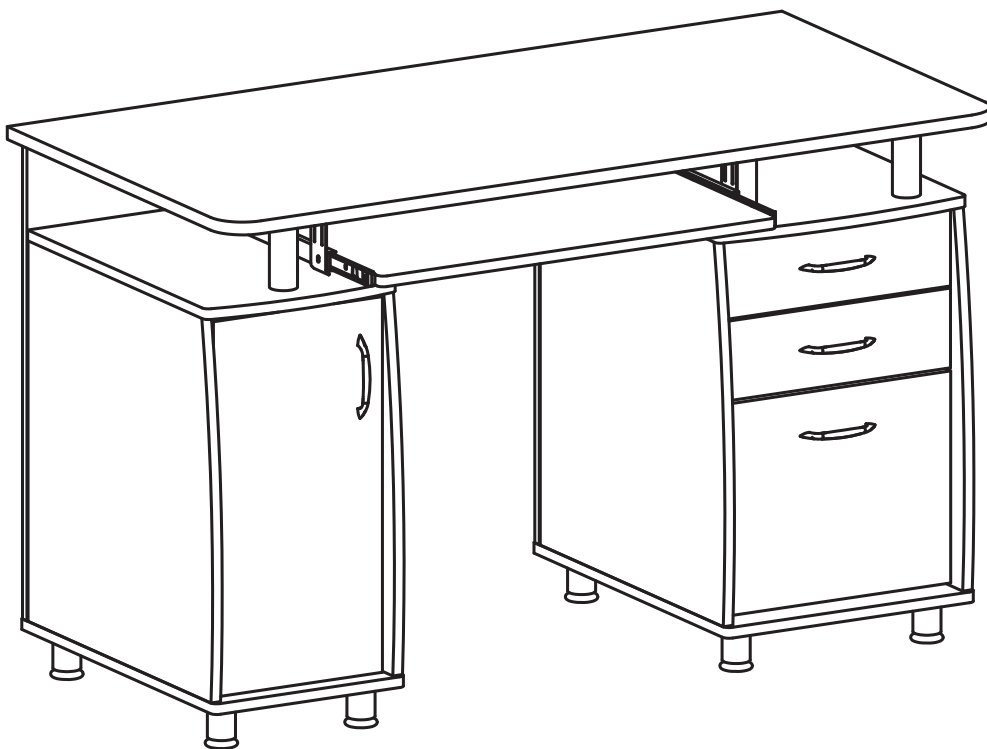



- Please read carefully the assembly instructions before the installation.







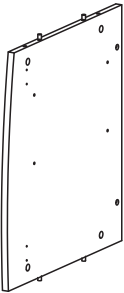
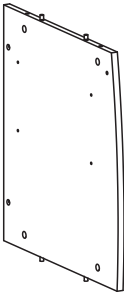
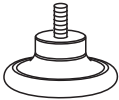
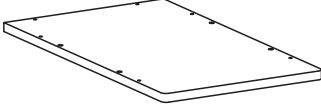
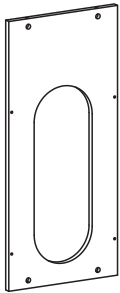
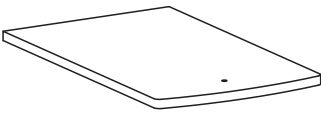
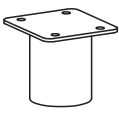
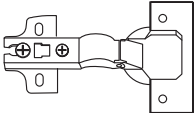
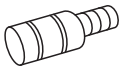
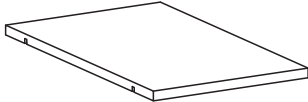
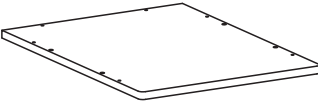
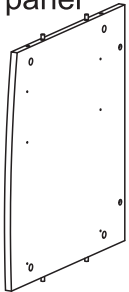
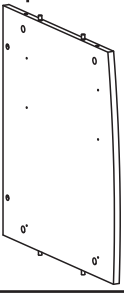
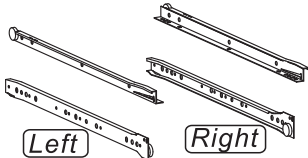
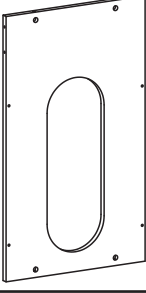
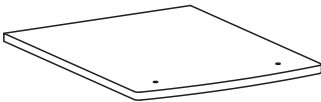
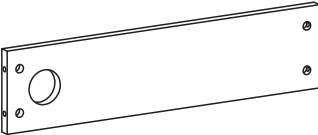
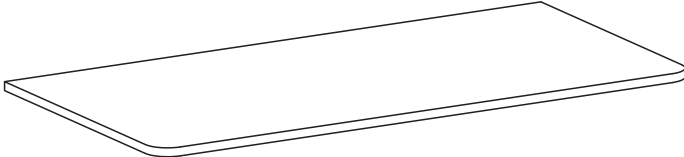
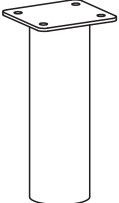

- Do not discard this manual or any of the packaging material until the unit has been completely assembled.

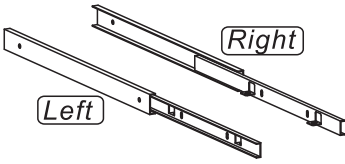

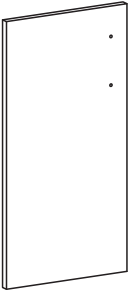

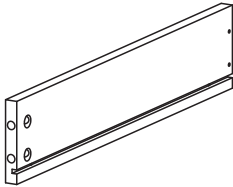
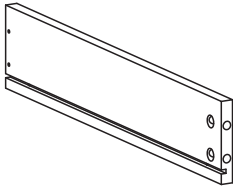
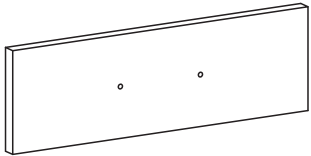
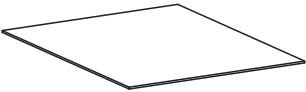
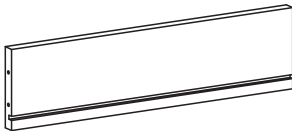
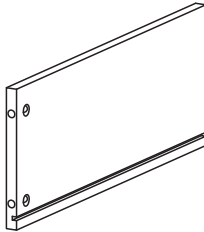
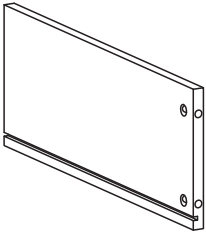
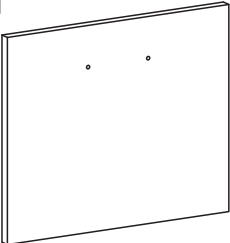
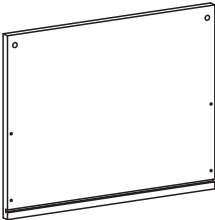
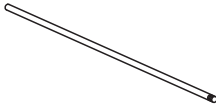
MAIN PARTS LIST

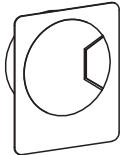



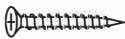

<p>1 CPU left panel x1</p> 	<p>2 CPU right panel x1</p> 	<p>3 Studs x8</p> 	<p>4 CPU bottom panel x1</p> 
<p>5 CPU back panel x1</p> 	<p>6 CPU top panel x1</p> 	<p>7 Base tubes x8</p> 	<p>8 Hinges x2</p> 
<p>9 Door stopper x1</p> 	<p>10 Adjustable panel x1</p> 	<p>11 File cabinet bottom panel x1</p> 	<p>12 File cabinet left panel x1</p> 
<p>13 File cabinet right panel x1</p> 	<p>14 Drawer sliders, SET for 1 drawer x3</p>  <p><i>Left</i> <i>Right</i></p>	<p>15 File cabinet back panel x1</p> 	<p>16 File cabinet top panel x1</p> 
<p>17 Central panel x1</p> 	<p>18 Main panel (tabletop) x1</p> 		<p>19 Support tubes for main panel x3</p> 

MAIN PARTS LIST

<p>20 Keyboard sliders SET x1</p> 	<p>21 Bases (brackets) for sliders x4</p> 	<p>22 Keyboard panel x1</p> 	<p>23 CPU door x1</p> 
<p>24 Handles x4</p> 	<p>25 Small drawer left panel x2</p> 	<p>26 Small drawer right panel x2</p> 	<p>27 Small drawer front panel x2</p> 
<p>28 Drawers bottom panel x3</p> 	<p>29 Small drawer back panel x2</p> 	<p>30 File drawer left panel x1</p> 	<p>31 File drawer right panel x1</p> 
<p>32 File drawer front panel x1</p> 	<p>33 File drawer back panel x1</p> 	<p>34 Hanging file tubes, SET of 2 pcs x1</p> 	<p>35 Metal pins SET of 4 pcs x1</p> 
<p>36 Grommet x1</p> 			

LIST OF SCREWS AND TOOLS

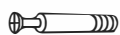
PART	QTY.	ITEM	
A	3	6X35 MM	
B	12	4X35 MM	
C	24	3X15 MM	
D	8	4X20 MM	
E	16	6X40 MM	
F	48	4X14 MM	

PART	QTY.	ITEM	
G	8	4X16 MM	
H	4	6X12 MM	
I	4	4X4 MM	
J	3	Φ 40 MM	
K	32	6X25 MM	
	1		

MAIN PARTS LAYOUT (FOR REFERENCE):

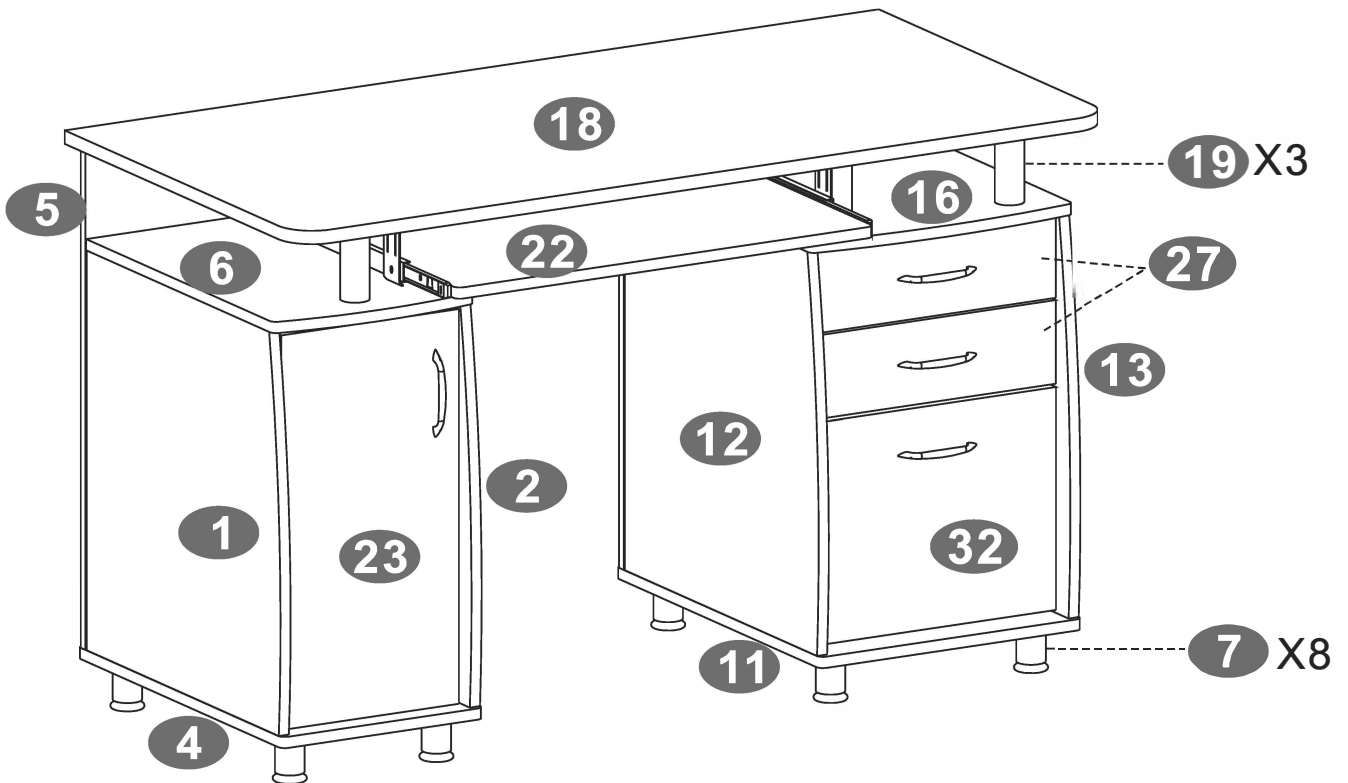

☞ This unit uses cam bolts and locks. The following explains how to use them. This is not an assembly step; it is a guide for when you are actually doing the assembly using this kind of hardware.

Cam Bolt



Cam Lock



1. Screw the bolt into the corresponding panel.

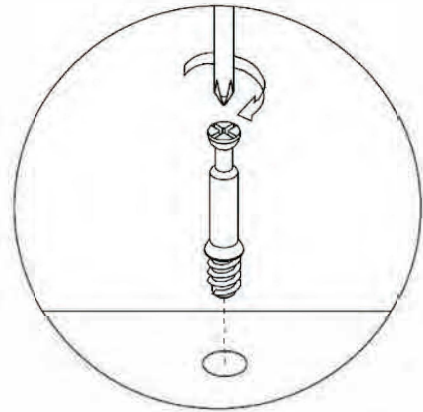
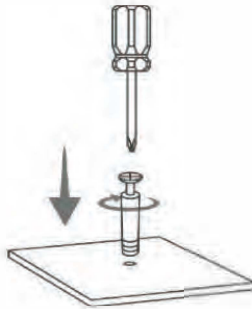

2. In the other panel, insert the cam lock and align it so it can properly receive the bolt, then join both panels. There might be a very small gap between the panels which is normal.

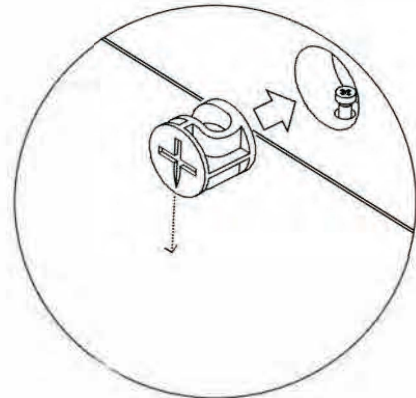
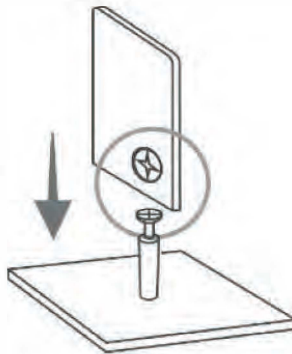

ALIGNMENT DIRECTION

3. Turn the cam lock clockwise to lock the parts together if there was a small gap it will also close.

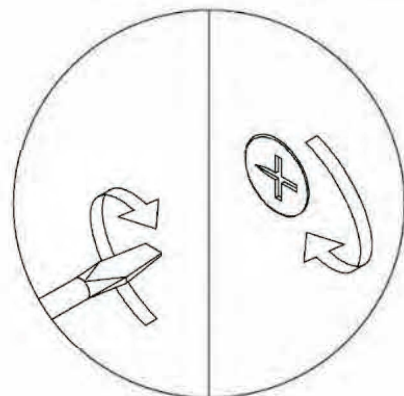
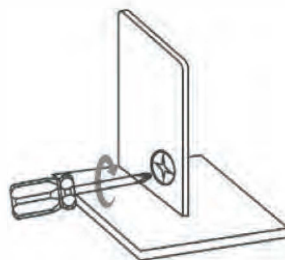

BEFORE YOU START THE ASSEMBLY, PLEASE READ THE FOLLOWING TIPS AND WARNINGS.

1 Do a quick inventory to make sure the package contains all the parts and hardware listed in the assembly instructions.



7 To avoid misalignments, always leave the screws loose and tighten them until all pieces are positioned correctly.

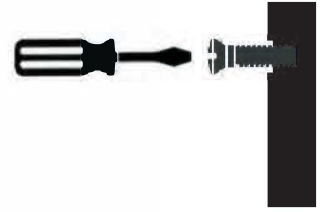

2 Missing, damaged and defective parts can be replaced at no cost to you. Please refer to the CONTACT card included with the product.



8 Do not overtighten or force the screws as they might break, strip, damage the threads of the holes or get stuck inside the part.

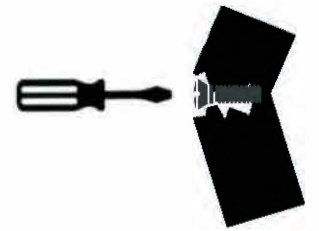

3 The replacement parts service is limited to the continental United States. If you reside in Hawaii, Puerto Rico, U.S. Dependencies or other countries, please contact the supplier from where the unit was purchased.



9 Sometimes the laminate might cover partially or entirely the hole on a panel. If there is no visible hole for the screw, pass and press the tip of your finger over the area where the hole should be located to feel the indentation, and once found, carefully pierce the laminate to reveal the hole underneath.



4 If during assembly you find an issue or need clarification, please contact our Customer Service for assistance. Please refer to the CONTACT card included with the product.



5 On each step read the instructions and analyze the illustrations thoroughly before proceeding to do the assembly.



10 If the hole seems too small for the screw, first make sure you are using the correct size of screw and that it's been installed in the correct hole. If the hole still appears to be too small, carefully pierce the laminate to reveal the hole's actual size.



6 Make sure you understand which hardware will be used on each step. Using the wrong size of screw, bolt or pin might strip the threads or cause damage to the part in which it is being used.

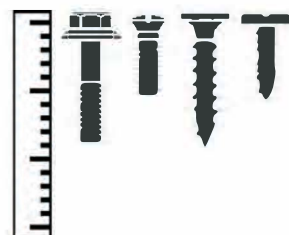

ASSEMBLY STEPS

STEP 1

First screw the bolts **K** into the back face of the small drawer front panel **27**, then assemble the drawer side panels **25** and **26** as shown and as explained in page 5.

Screws:

K	6x25mm	x4
----------	--------	----

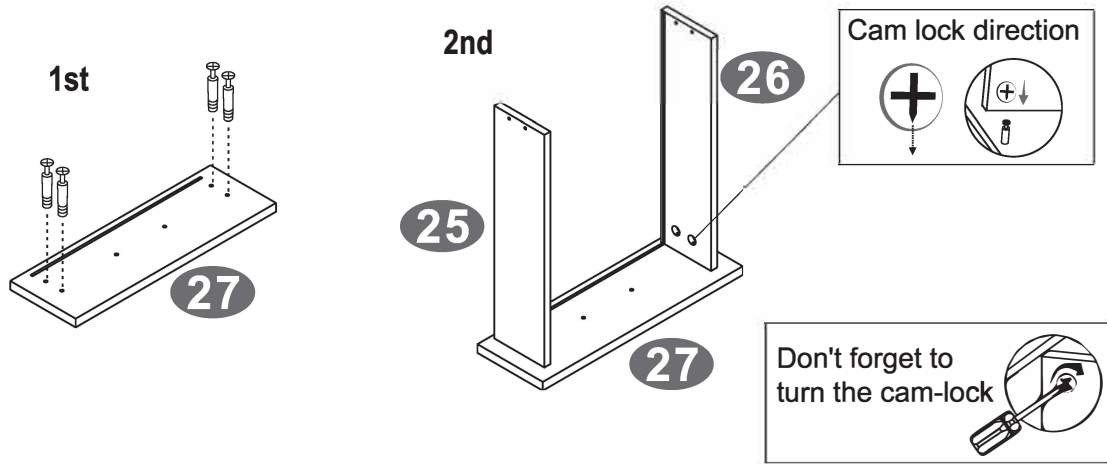

STEP 2

Slide the drawer bottom panel **28** through the groves of panels **25**, **26** and **27** as shown.

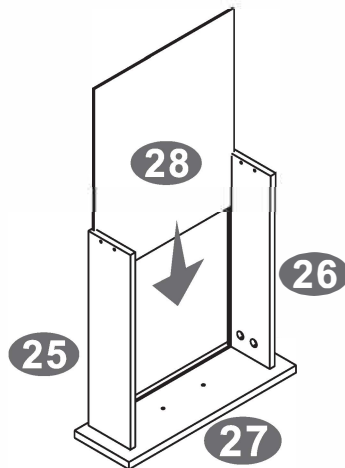

STEP 3

Use screws **B** to assemble the small drawer back panel **29** to the side panels **25** and **26** as shown.

Screws:

B	4x35mm	x4
----------	--------	----

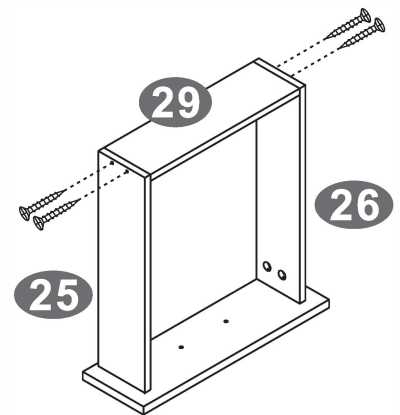

STEP 4

Grab 1 SET of drawer sliders **14**, and sort them by their shape:

- The "L" shaped will be used in this step.
- The flat ones will be used until step 21, so please set them aside.

With the drawer upside-down and its front facing away from you, assemble the "L" shaped sliders using screws **C** as shown.

Screws:

C	3x15mm	x4
----------	--------	----

ATTENTION: VERY IMPORTANT!

Correct **Incorrect**

The sliders must not protrude at the bottom

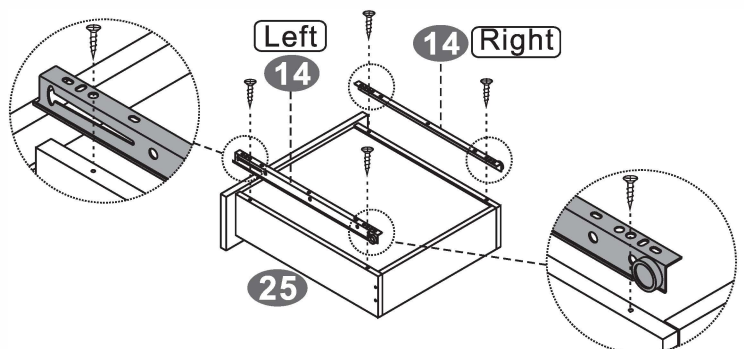

STEP 5

Assemble the handle **24** to the small drawer front panel **27** using screws **D** as shown.

Screws:

D	4x20mm	x2
		

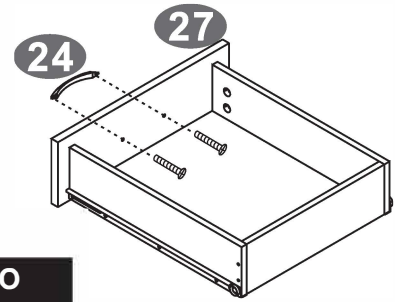

REPEAT STEPS 1 THRU 5 TO ASSEMBLE THE SECOND SMALL DRAWER

STEP 6

First screw the bolts **K** into the back face of the file drawer front panel **32**, then assemble the file drawer side panels **30** and **31** as shown and as explained in page 5.

Screws:

K	6x25mm	x4
		

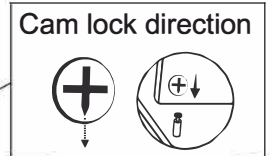
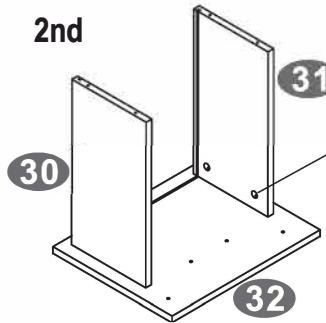
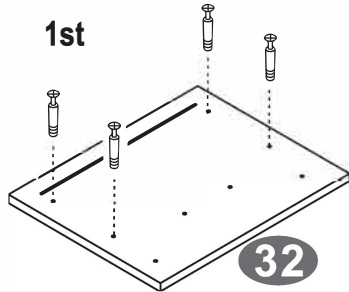

STEP 7

Slide the drawer bottom panel **28** through the grooves of panels **30**, **31** and **32** as shown.

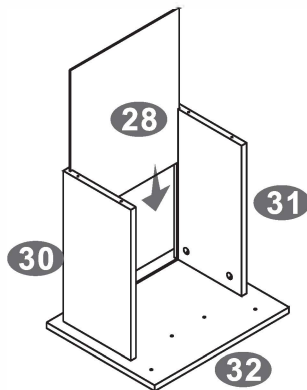

STEP 8

Use screws **B** to assemble the file drawer back panel **33** to the side panels **30** and **31** as shown.

Screws:

B	4x35mm	x4
		

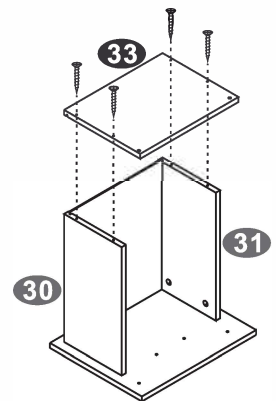

STEP 9

Insert the hanging file tubes **34** from the back through the file back panel **33** and into the threaded holes of the front panel **32** as shown.

IMPORTANT: Screw slowly and carefully, do not over tighten the tubes as they may perforate and damage the front panel! Such damage is not covered by the product's warranty.

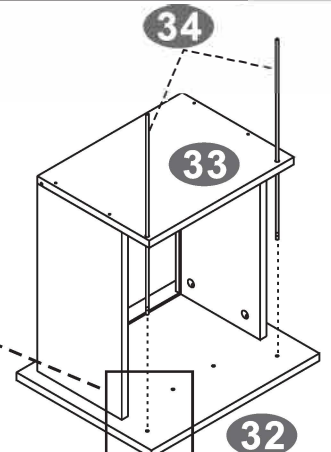
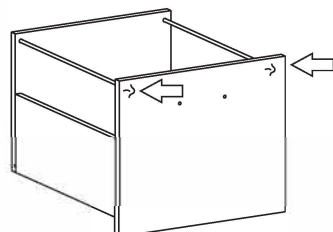

STEP 10

Screws:

C	3x15mm	x4
----------	--------	----

Grab the last SET of drawer sliders **14**, and sort them by their shape:

- The "L" shaped will be used in this step.
- The flat ones will be used until step **25**, so please set them aside.

With the drawer upside-down and its front facing away from you, assemble the "L" shaped sliders using screws **C** as shown.

ATTENTION: VERY IMPORTANT!

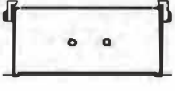
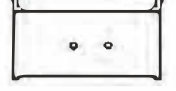
Correct	Incorrect
	

The sliders must not protrude at the bottom

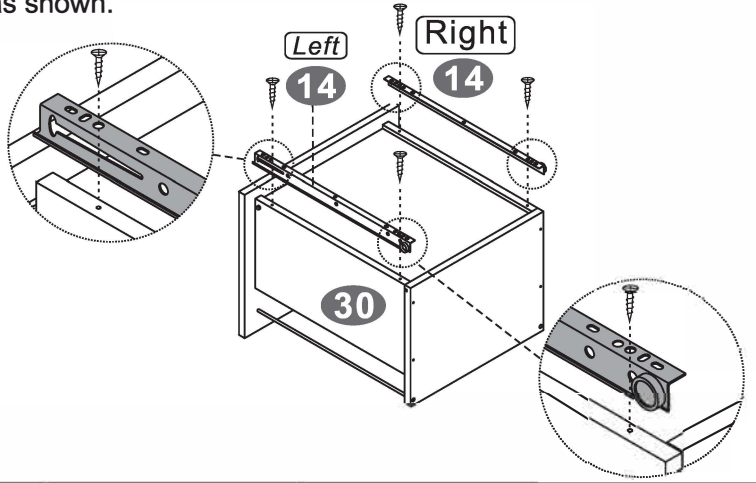

STEP 11

Screws:

D	4x20mm	x2
----------	--------	----

Assemble the handle **24** to the front panel **32** using screws **D** as shown.

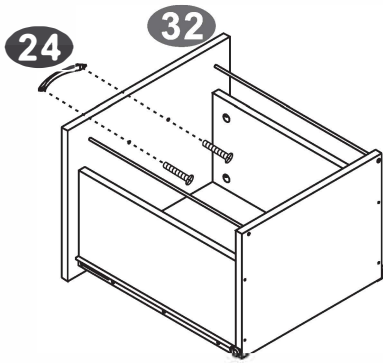

STEP 12

Screws:

F	4x14mm	x16
----------	--------	-----

Assemble the base tubes **7** to the bottom face of the CPU bottom panel **4** using screws **F** as shown.

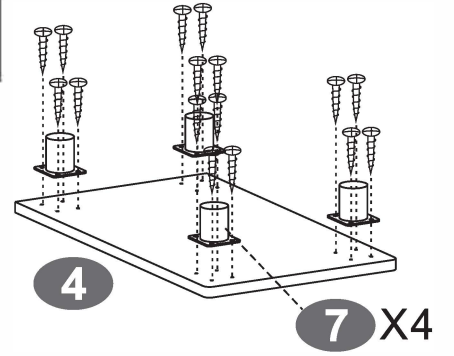

(This panel is narrower than panel 11)

STEP 13

Attach the studs **3** to the base tubes **7** as shown.

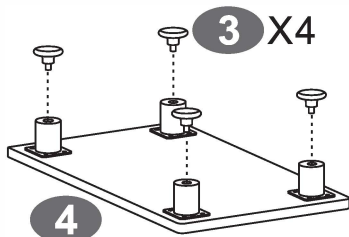

STEP 14

Screws:

K	6x25mm	x4
----------	--------	----

First screw the bolts **K** into the CPU back panel **5**, then assemble the CPU side panels **1** and **2** as shown and explained in page 5, and then install the door stopper **9** as shown.

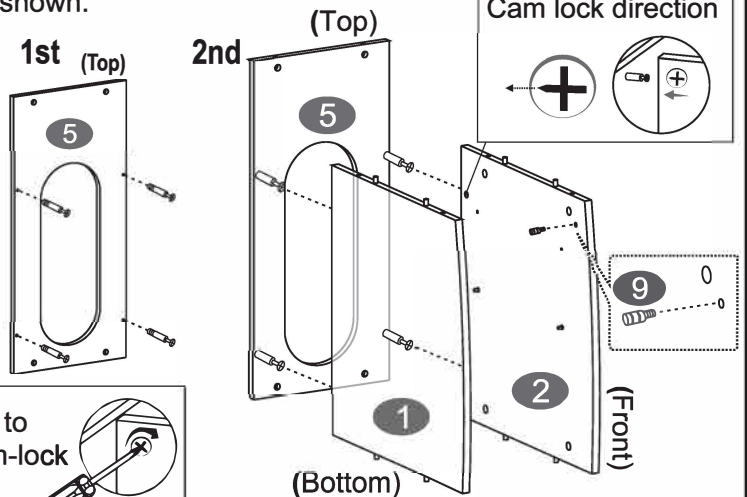

Don't forget to turn the cam-lock

(The panels 1 and 2 are wider at the bottom)

STEP 15

First screw the smaller bolts **K** to the back end of the panel **4**, then screw the longer bolts **E** on the sides as shown.

Screws:

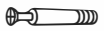
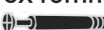
K	6x25mm 	x2
E	6x40mm 	x4

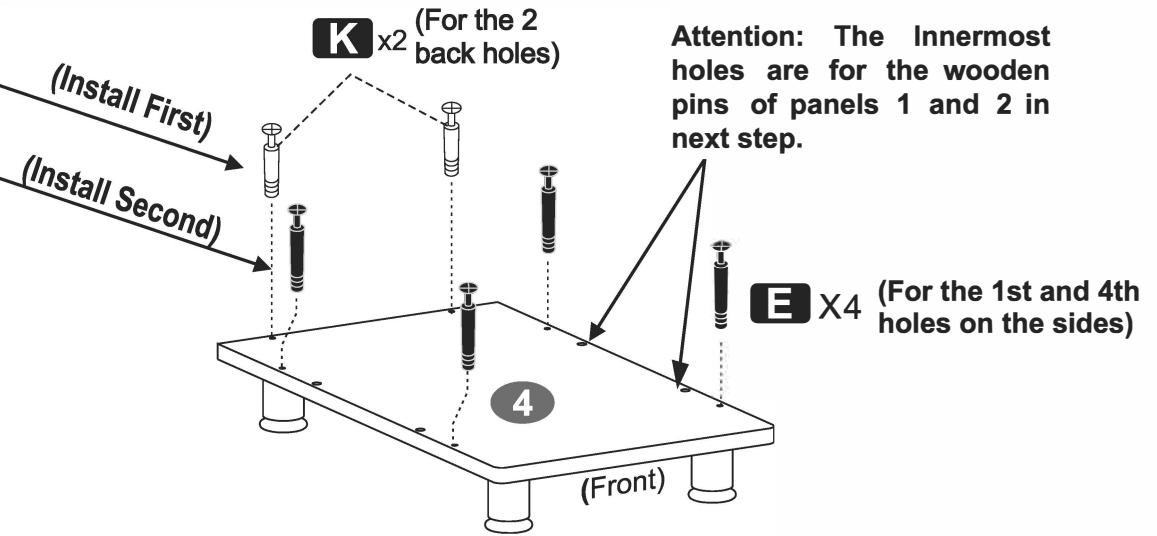

STEP 16

Assemble the CPU panels **1 - 2 - 5** to the CPU bottom panel **4** as shown and explained in page 5.

Troubleshoots:

Problem: The panels don't come down flush and there is a gap.

Solution 1: Review and make sure you installed the correct size of bolts in the correct positions in step 15.

Solution 2: Make sure the cam locks on panels **1, 2** and **4** are properly aligned to receive the bolts.

Problem: The cam locks don't turn or turn less than half way.

Solution: Remove the panels, align the cam locks and insert a screwdriver in every hole, jiggling it a little to allow the cam lock to align inside the panel.

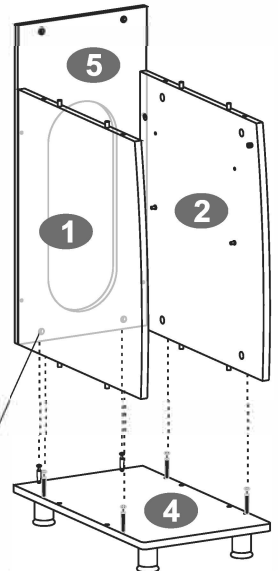
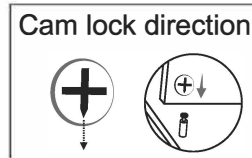

STEP 17

First screw the bolts **E** to the bottom face of the CPU top panel **6**, then assemble the panel to panels **1** and **2** as shown and as explained in page 5.

Screws:

E	6x40mm 	x4
----------	---	----

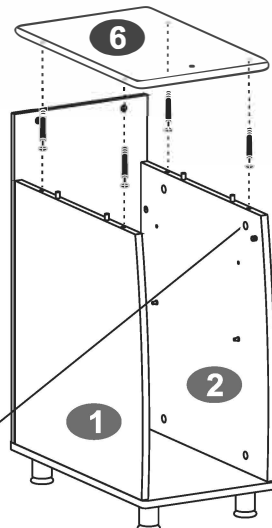
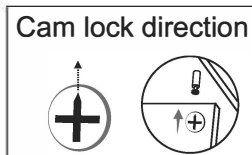

STEP 18

Insert the metal pins **35** into the set of holes of the side panels **1** and **2** according to your desired height, then place the adjustable panel **10** over the pins.

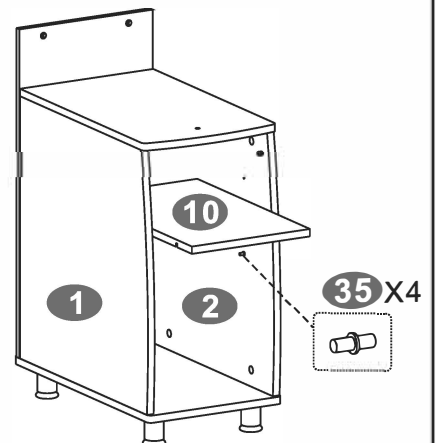

STEP 19

Assemble the base tubes 7 to the bottom face of the file cabinet bottom panel 11 using screws F as shown.

Screws:

F	4x14mm	x16
----------	--------	-----

(This panel is wider than panel 4)

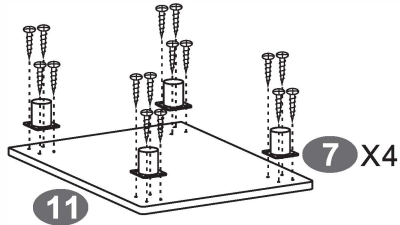

STEP 20

Attach the studs 3 to the base tubes 7 as shown.

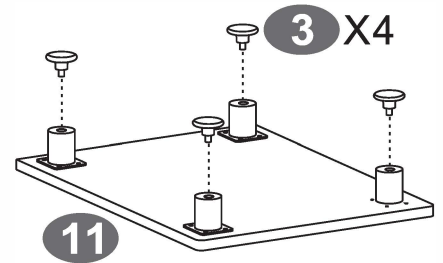

STEP 21

With the cabinet side panels 12 and 13 oriented as shown, assemble 2 sets of the flat sliders 14 to the top and middle sets of holes using screws C as shown. Note that the wheel is facing towards the front of the panels and down with 2 empty holes (on the slider) above it. THE BOTTOM SET OF FLAT SLIDERS ARE INSTALLED UNTIL STEP 25.

Screws:

C	3x15mm	x8
----------	--------	----

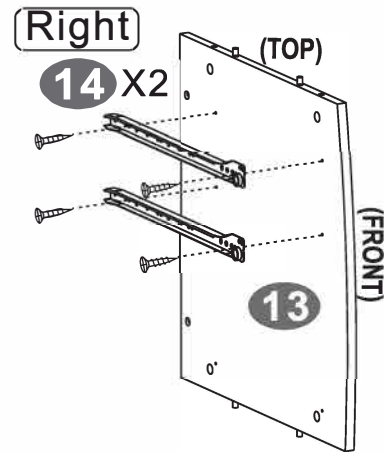
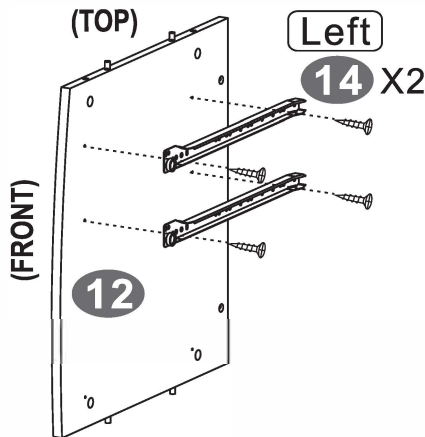
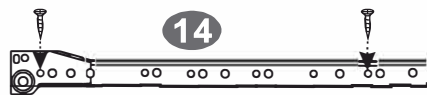

STEP 22

First screw the bolts K into the interior face of the cabinet back panel 15, then assemble the side panels 12 and 13 as shown and explained in page 5.

Screws:

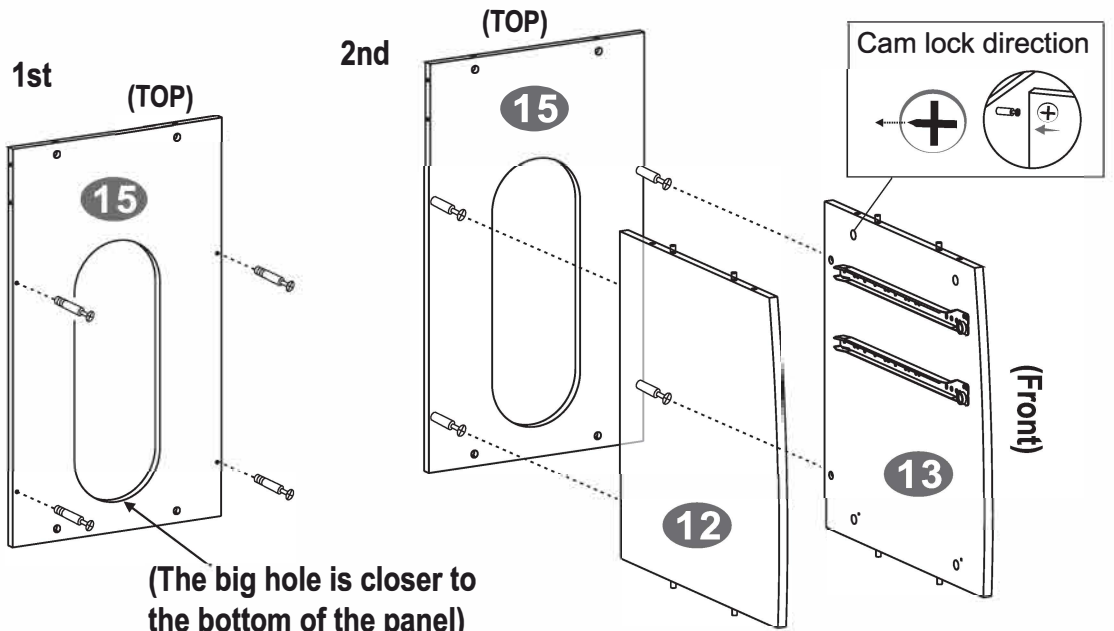

K	6x25mm	x4
----------	--------	----



STEP 23

First screw the smaller bolts **K** to the back end of the panel **11**, then screw the longer bolts **E** on the sides as shown. Finally, assemble the panels **12**, **13** and **15** as shown and as explained in page 5.

Screws:

K	6x25mm 	x2
E	6x40mm 	x4

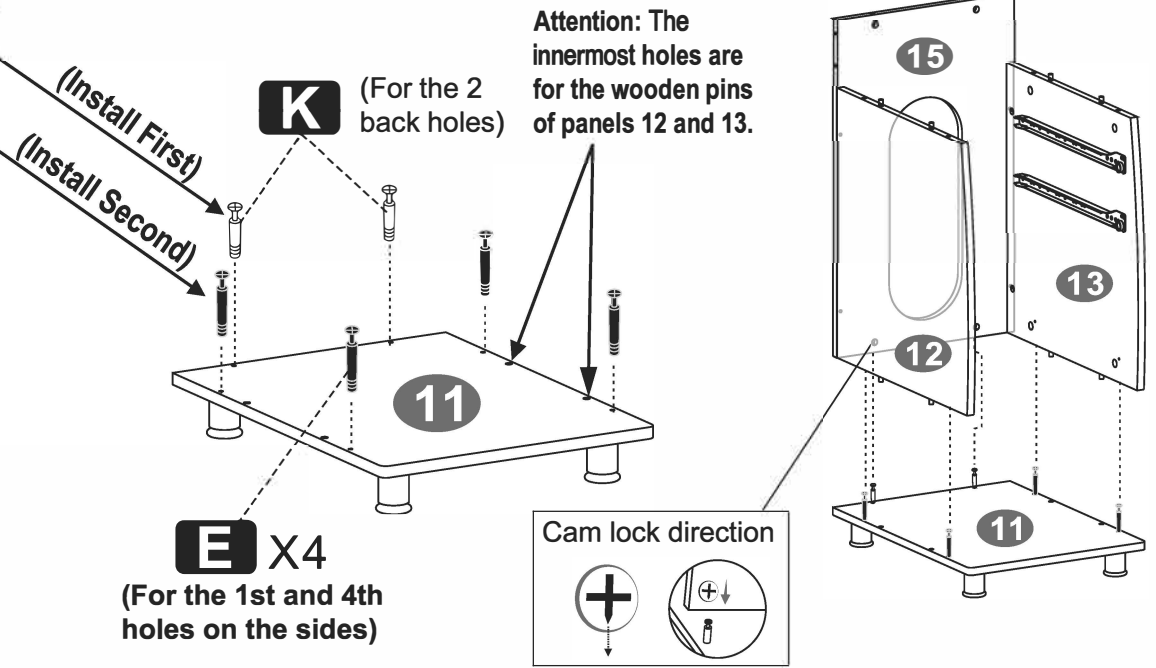

Troubleshoots:

Problem: The panels don't come down flush and there is a gap.

Solution 1: Review and make sure you installed the correct size of bolts in the correct positions.

Solution 2: Make sure the cam locks on panels **12**, **13** and **15** are properly aligned to receive the bolts.

Problem: The cam locks don't turn or turn less than half way.

Solution: Remove the panels, align the cam locks and insert a screwdriver in every hole, jiggling it a little to allow the cam lock to align inside the panel.

STEP 24

First screw the bolts **E** to the bottom face of the cabinet panel **16**, then assemble the panels **12** and **13** as shown and as explained in page 5.

Screws:

E	6x40mm 	x4
----------	---	----

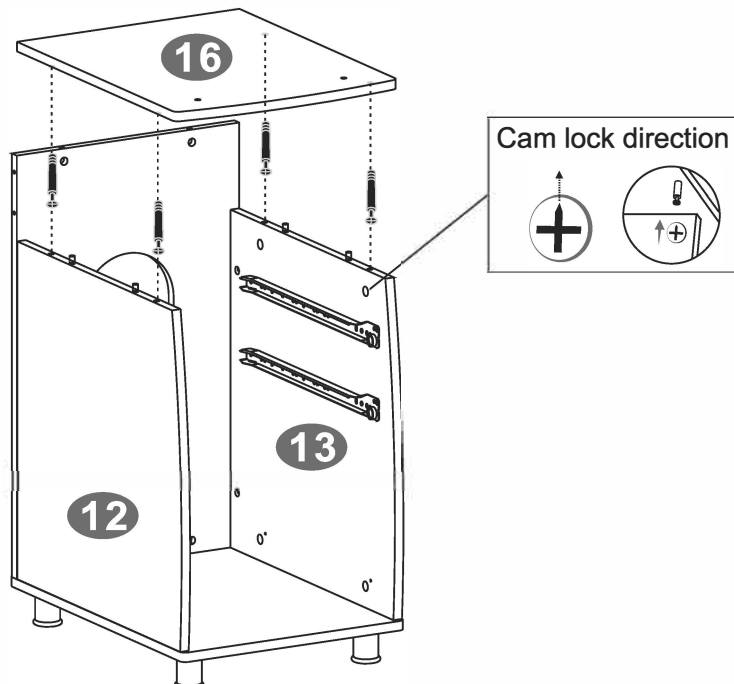

STEP 25

Assemble the last set of flat sliders **14** to the bottom sets of holes on the side panels **12** and **13** using screws **C** as shown. Note that the wheel is facing towards the front of the panels and down with 2 empty holes (on the slider) above it.

Screws:

C

3x15mm

x4

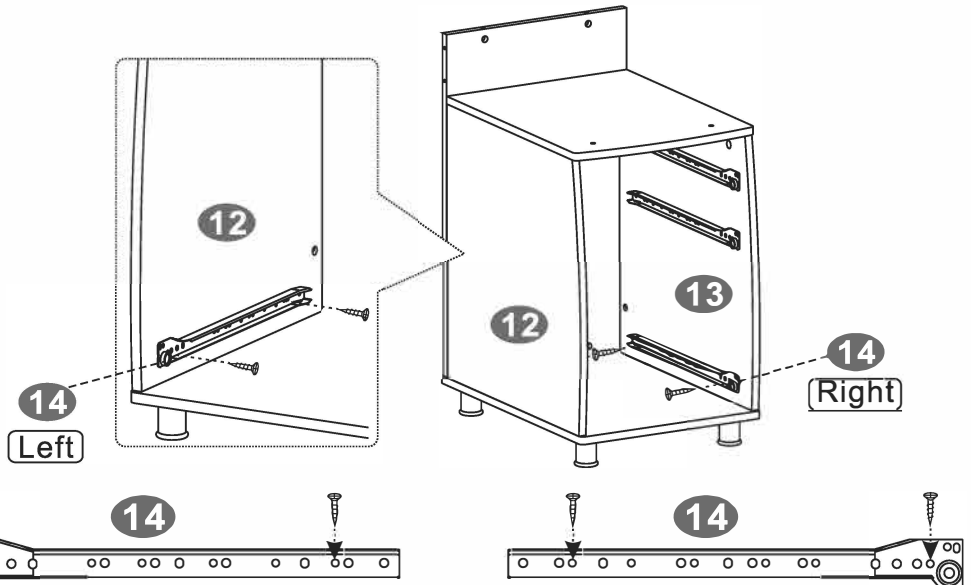

STEP 26

First screw the bolts **K** to panels **5** and **15** as shown, then assemble to both panels the central panel **17** as shown and as explained in page 5, and finally, insert the grommet **36** into panel **17** from the outside as shown.

Screws:

K

6x25mm

x4

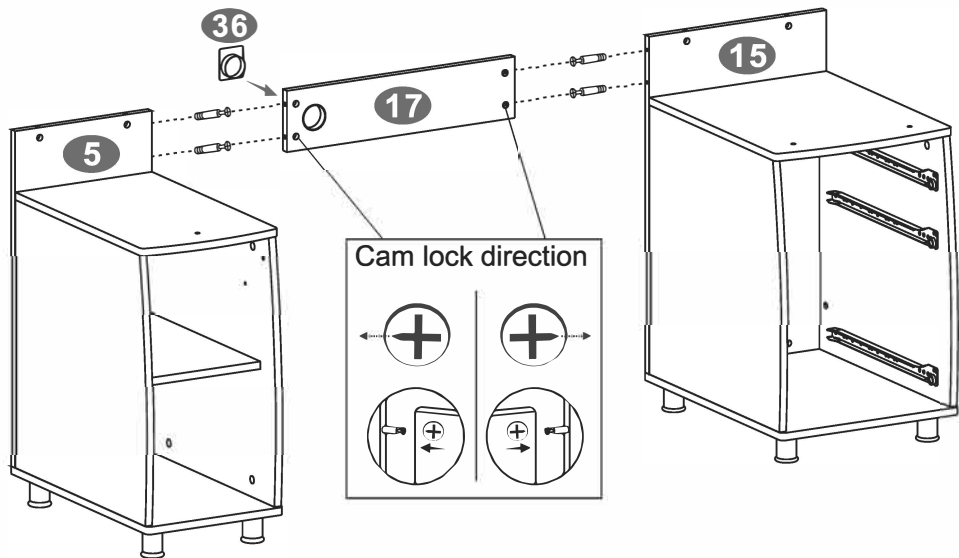
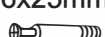

STEP 27

Assemble the support tubes for main panel **19** on the bottom face of the main panel **18** using screws **F** as shown.

Screws:

F

4x14mm

x12

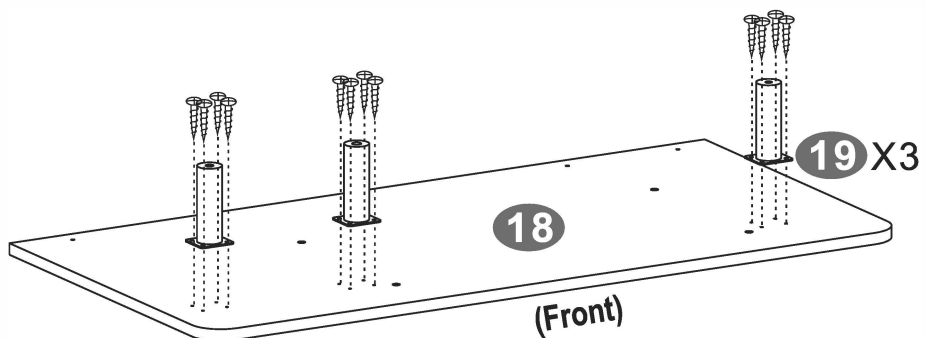
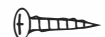

STEP 28

Use screws **H** to assemble the slider bases **21** to the back face of the main panel **18**, with the bases oriented towards the outside as shown.

Screws:

H

6x12 mm

x4



Bases are oriented towards the outside

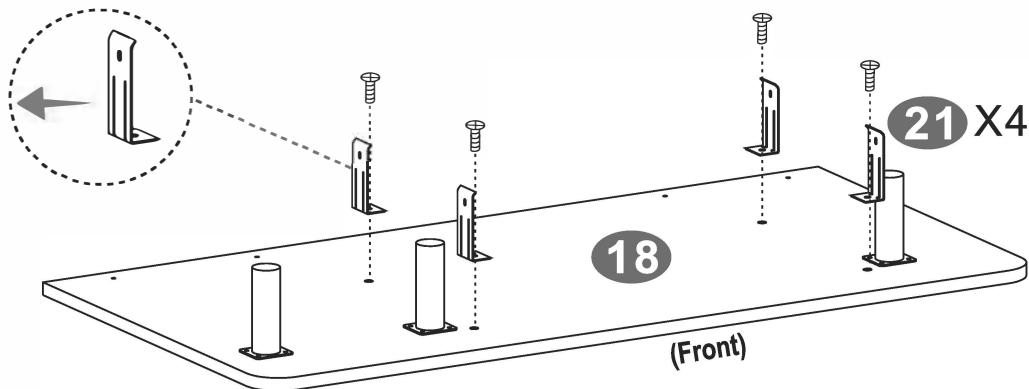

STEP 29

Use screws **I** to assemble the keyboard sliders **20** to the slider bases **21** as shown.

MAKE SURE YOU ARE ASSEMBLING THE SLIDERS CORRECTLY:

Screws:

I

4x4mm

x4



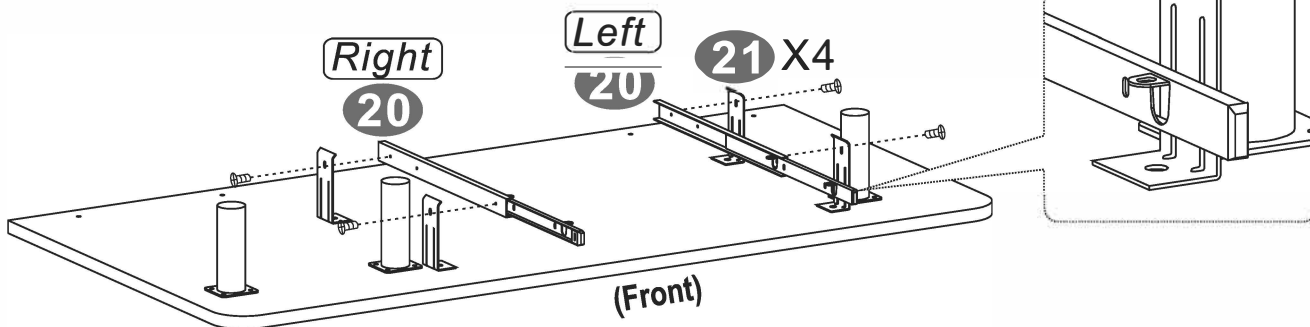

- The flat side of the sliders are positioned touching the bases.
- The tabs on the sliders face up.
- The screw is inserted from the outside through the base hole and into the threaded hole of the slider.
- The sliders will slide towards the front.



STEP 30

Screws:

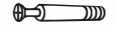
A	6x35mm 	x3
J	Ø 40mm 	x3
K	6x25mm 	x4

First screw bolts **K** to the main panel **18** as shown. Then with the help of another person, place the main panel over the frame, making sure the bolts enter into the holes of the back panels **5** and **15** , **BUT DO NOT LOCK THE CAM LOCKS YET**. Then place plastic washers **J** over the holes of the cabinets, and secure the support tubes **19** using screws **A** from underneath the frame. Finally, lock the cam locks as explained in page 5.

 MIGHT REQUIERE 2 PEOPLE

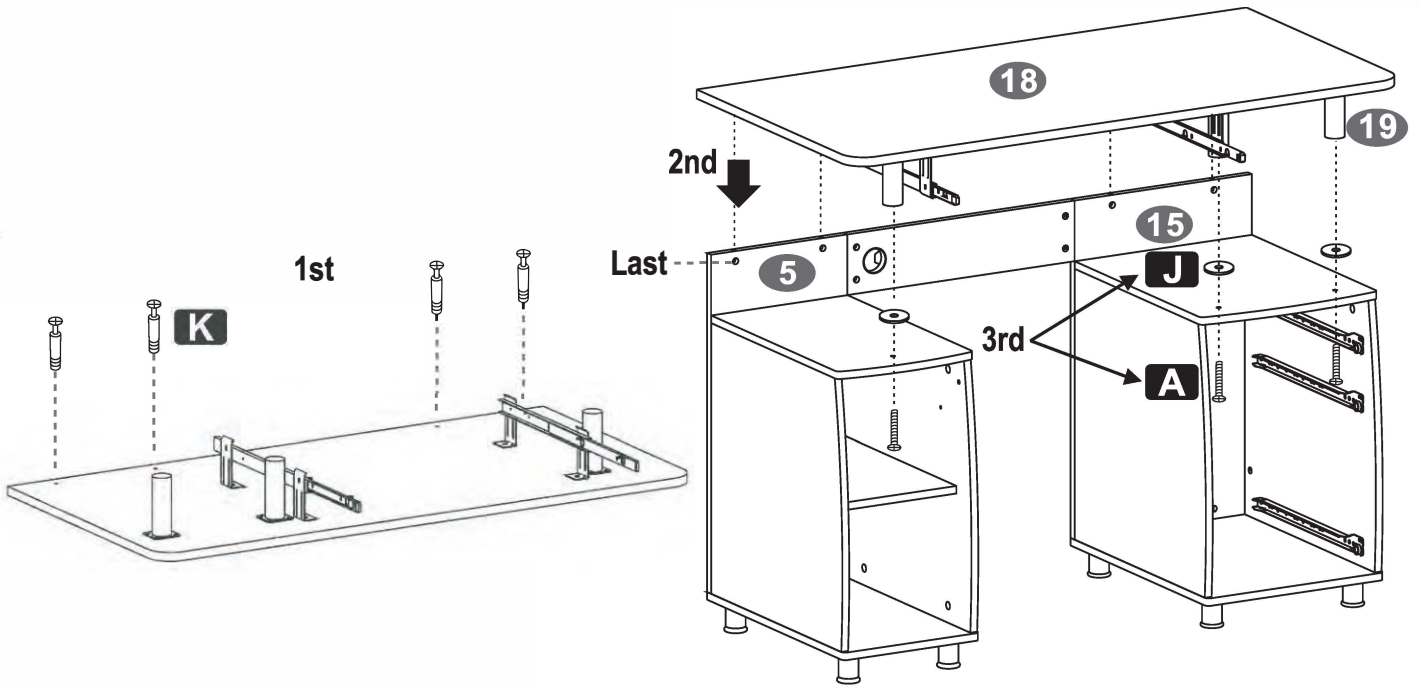

STEP 31

Screws:

F	4x14mm 	x4
----------	---	----

Extend the keyboard sliders **20** and place the keyboard panel **22** over the tabs, making the holes coincide, and secure the panel using screws **F** from underneath as shown.

The tabs on the sliders face down, and the panel rests on the tabs.

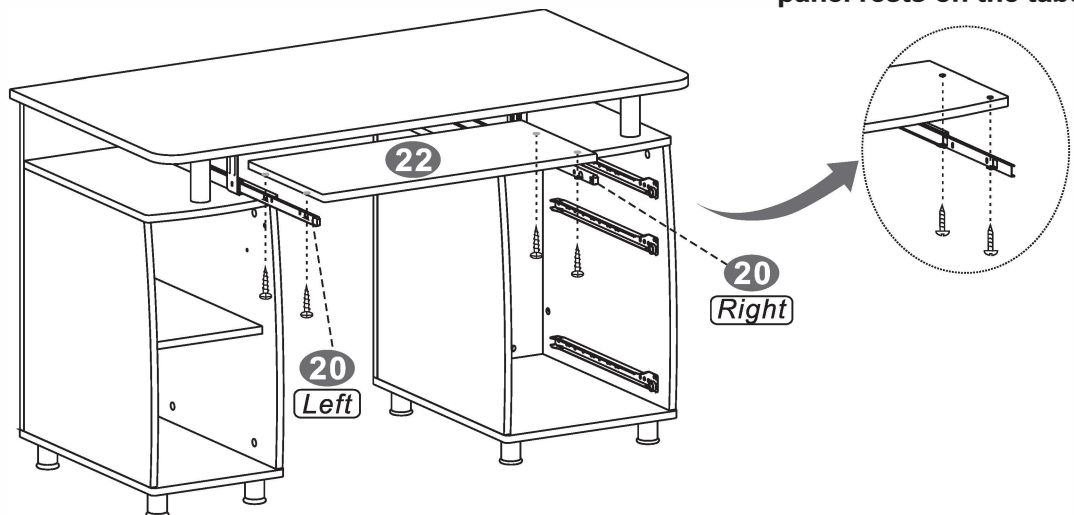

STEP 32

Use screws **G** to assemble the hinges **8** to the CPU door **23**.

Screws:

G	4x16mm	x4
----------	--------	----

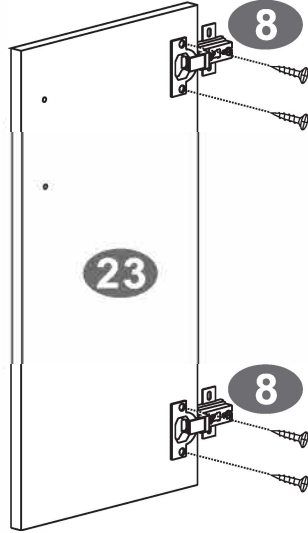
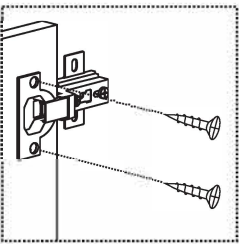

STEP 33

Use screws **D** to assemble the handle **24** to the CPU door **23**.

Screws:

D	4x20mm	x2
----------	--------	----

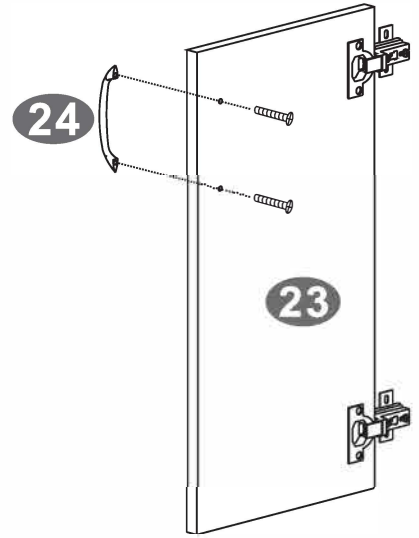

STEP 34

Use screws **G** to assemble the hinges **8** on the CPU door **23** to the CPU left panel **1** as shown.

Screws:

G	4x16mm	x4
----------	--------	----

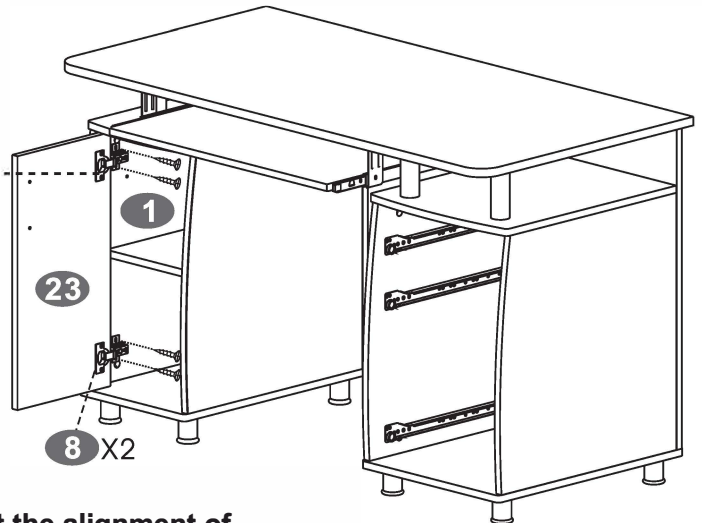
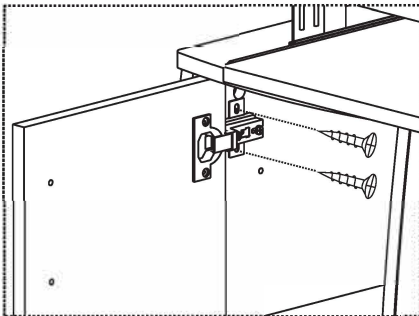

If the door does not close properly, you can adjust the alignment of the hinges by adjusting the following screws:

<p>Adjust side-to-side:</p>	<p>Adjust the height:</p>	<p>Adjust the depth:</p>

STEP 35

Insert the drawers into the cabinet, starting with the bottom drawer. For the top drawer, you might have to insert it at a downward tilted angle. The wheel on the drawer will run in the middle of the sliders on the cabinet.

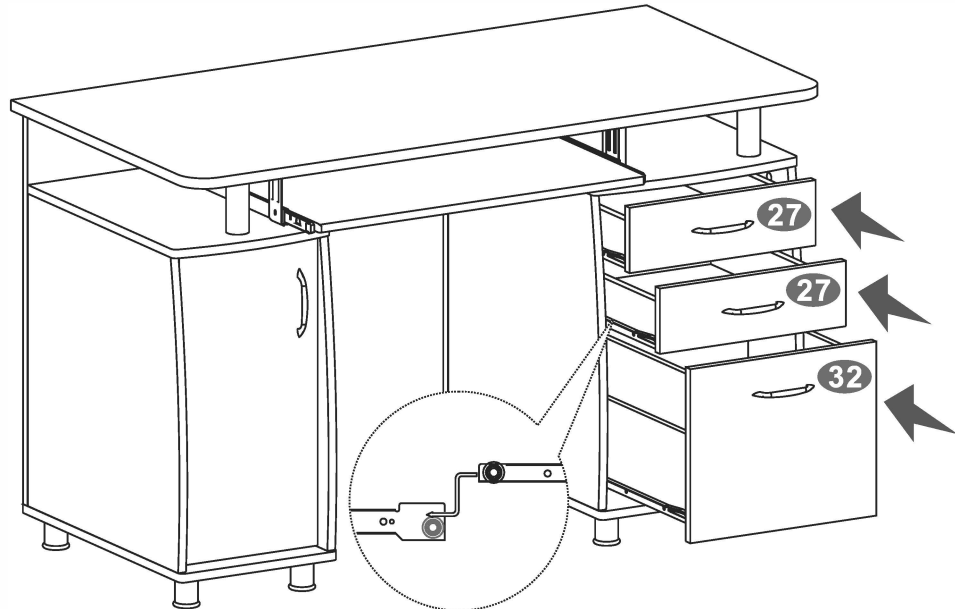
**Troubleshoot:**

Problem: There is a gap at the bottom of the file drawer and/or the top drawer doesn't fit.

Reason: The drawers sliders are rising the drawers more than what it should be.

Solution: Review steps 4 and 10 for the correct assembly of the sliders on the drawers.

Problem: The bottom drawer hits the bottom panel and/or there is a gap at the top of the top drawer.

Reason: The sliders inside the cabinet are tilted down at the front.

Solution: Review steps 21 and 25 for the correct assembly of the sliders inside the cabinet.



ALL DONE!

Give yourself a nice pat on the back. You did a great job!

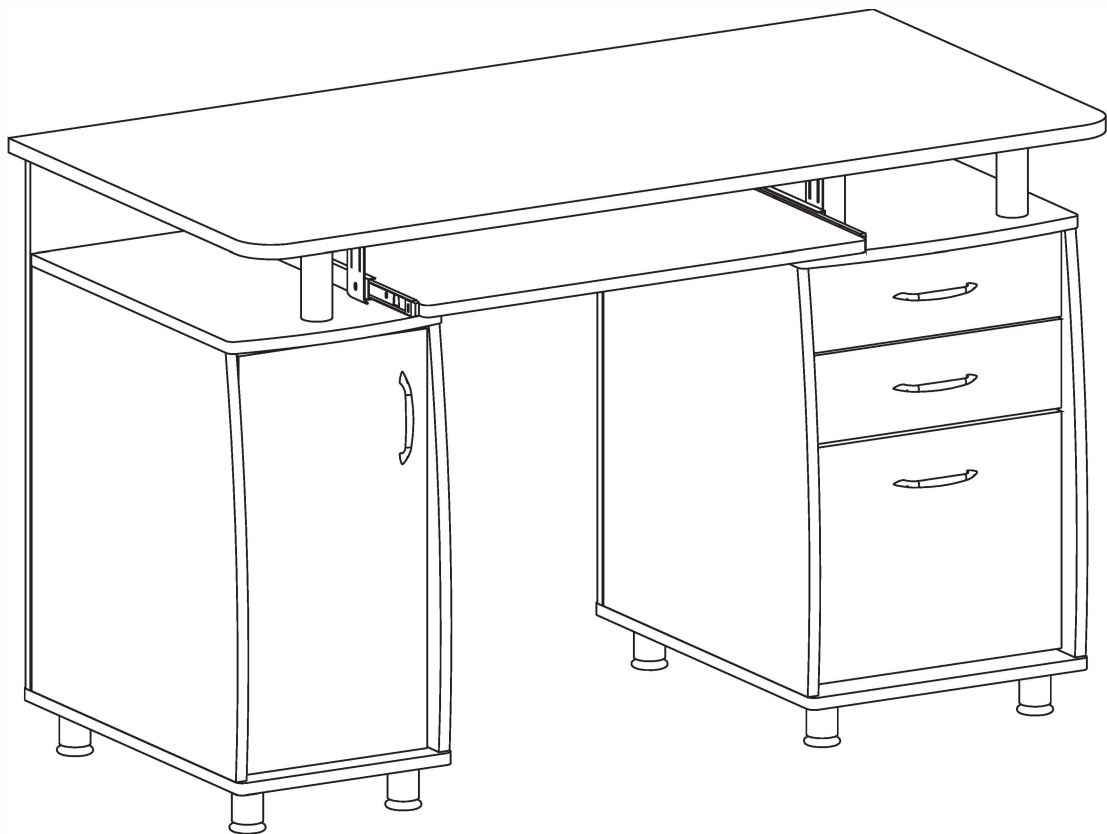

AFTER THE ASSEMBLY IS DONE, PLEASE READ CAREFULLY THE FOLLOWING CARE AND MAINTENANCE WARNINGS:

MAXIMUM WEIGHT CAPACITIES

(DO NOT EXCEED THESE LIMITS)

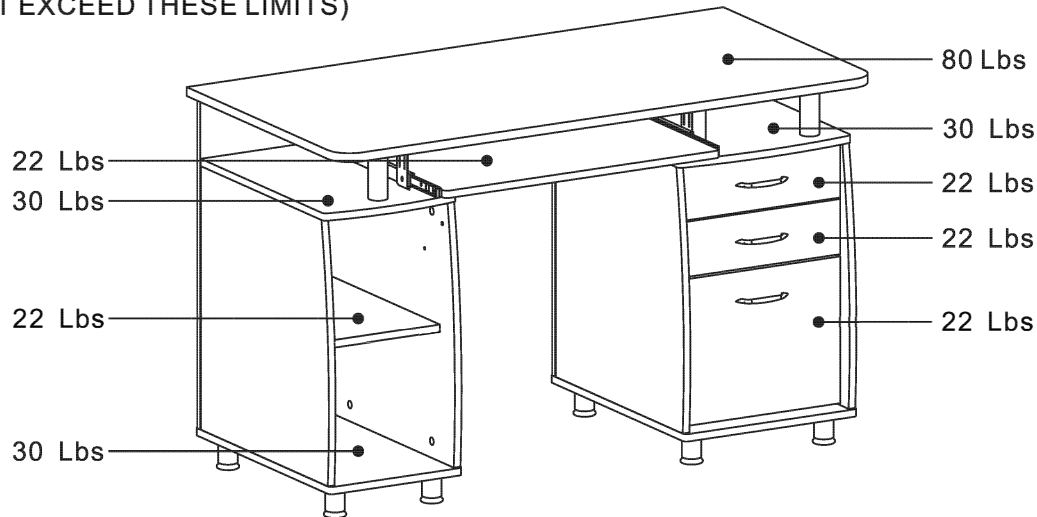

- Do not exceed the indicated weight limits.
- Do not expose the surfaces to direct sunlight or to extreme environmental conditions.
- Clean the surfaces preferable with a clean cloth damped in a solution of mild soap and water, then dry with a clean towel.
- Do not use solvents or abrasive materials to clean the unit.
- If you decide to use a cleaning agent, test first on an area hidden from view such as underneath the tabletop.
- Do not seat on the unit or lean against it.
- Do not allow small children to play under or over the unit.
- Do not allow small children to reach inside the drawers or compartments without your supervision.
- Do not pull, push or drag the unit to move it for more than 1 feet. The unit must be lifted by at least 2 persons when moving in the same or adjacent rooms.
- Before moving the unit, make sure to secure or remove any object that is heavy or might fall off. Please note that lifting from the tabletop with too much weight on the product might lead to part damage/separation.
- When lifting the unit, use both hands and bend your knees, not your backs.
- When transporting the unit to places far away, protect and secure the unit to avoid damage in transit.
- Shall any part of the unit become defective during the warranty period, replacement parts might be available to you at no charge. Please refer to the last pages on this manual.
- The warranty does not extend to regular wear and tear, nor the manufacturer assumes liability for damages or consequences due to accidents, incorrect assembly, negligence, improper use, modifications, or not heeding the above warnings.

DESKS/LAPTOP CARTS/FILE CABINETS: LIMITED 5-YEAR WARRANTY
TV Stand/Entertainment Center: 2 YEAR WARRANTY

We warrants to the Original Purchaser who acquired a new product or its authorized resellers that this product will be free from defects in its workmanship and materials, under normal use and service conditions, as described herein. "Defects" as used in this warranty, is defined as any imperfections that impair the use of the furniture or product. We will replace any defective part, at its discretion, and without charge to the original purchaser other than the freight from the end consumer.

Replacement parts can only be supplied if parts are available. Items out of production may be unavailable. This warranty will be effective for the applicable time period beginning the date of purchase on your original sales receipt. The obligation under this warranty is limited to repairing or replacing products or parts as provided herein. This product has been designed for and is intended for office and home-office use only. This warranty is Original Purchaser's sole remedy for product defects, and this warranty does not extend to any product, or damage to any product, caused by or attributed to abuse or misuse, products used for commercial or rental purposes, use modifications of, or attachments to the product, and products or parts not used, maintained, or extended hereunder is in lieu of any and all other warranties, express or implied, including without limitations any implied warranty or merchantability or of fitness for a particular purpose. Please note, all desks made with PVC Laminate surface should not be exposed to direct sunlight, as it may damage the material. Damage of this nature is not covered under this warranty.

We will not be responsible for indirect, special, incidental or consequential damages. This warranty is limited to merchandise purchased in the Continental United States. Some States do not allow the exclusion or limitation of incidental or consequential damages, so the above limitations or exclusions may not apply to you. This warranty gives you specific legal rights. You may also have other rights that may vary from state to state.