

Jarvis L-shaped standing desk

Assembly instructions

For assembly assistance,
visit fully.com/howtojarvis
or call 888-508-3725
or email support@fully.com

fully

Thank you for choosing a Jarvis desk
from Fully.

Cautions and use	1
Before starting	1
In the box	2
Assembly	3
Setup	22
Custom settings	22
Troubleshooting	25
Reset procedure	25
Using your own desk top	26
Specs	28
Contact	28

Cautions

Please read this manual carefully. If this desk changes hands, please provide this manual to the new owner.

Make sure the desk top is not touching any obstacles or walls. Make sure no obstacles are in the desk's path. Make sure all cords are an appropriate length to accommodate the full range of height adjustment.

Keep children away from desk components. There is risk of injury and electric shock.

Do not sit or stand on the desk frame. Do not crawl or lie under the desk frame.

Do not open or modify any of the components, including the Lifting Columns, Control Box, or Handset. Doing so risks electric shock and voids any warranty claims.

Placing objects taller than 20" underneath the desk will obstruct the desk's movement and may result in physical damage.

Voltage converters

Using a voltage converter could cause damage to the desk, and is considered improper use. Resulting damage is not covered by the warranty.

Verify the voltage of the Control Box as labeled to avoid damage. Alternative voltage Control Boxes are available from Fully.

Use & liability

This Jarvis height adjustable desk has electric motors and is designed for use in dry work environments only.

This Jarvis desk is adjustable so it can be positioned at an optimal ergonomic height. Any extra-curricular use is at user's own risk.

Under no circumstances does the manufacturer accept warranty claims or liability claims for damages caused by improper use or handling of the desk frame.

Jarvis is a registered trademark of Fully, Inc. All rights reserved.

Before starting

On a padded or carpeted area, take all of the items out of your Jarvis two frame boxes, and confirm that nothing is missing. Reference the included parts listings on page 2.

Pro tip

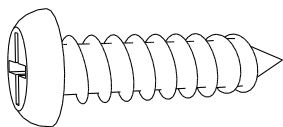

Wood Screws: Pointy End

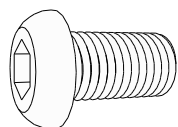

Machine Screws: Flat End

Tools



4mm Hex Wrench
(included)



5mm Hex Wrench
(included)

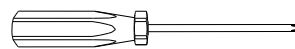

Phillips Head Screwdriver
(not included)

In the box

FRAME PARTS

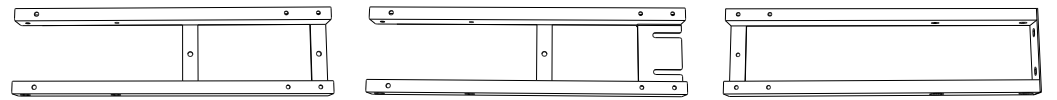

Frame End x1 Bracket Frame End x1 Corner Frame End-A x1



Corner Frame End-B x1 Center Rail Support x1 Center Rails x4

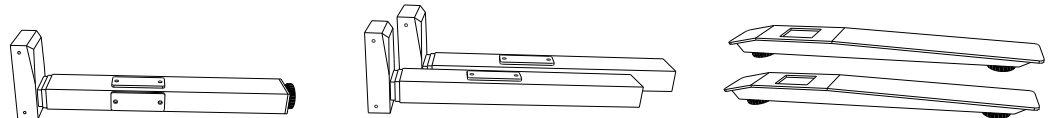

Corner Leg x1 Side Leg x2 Foot x2

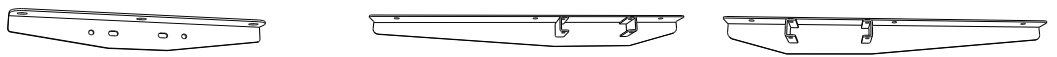

Corner Bracket x1 Left Side Bracket x1 Right Side Bracket x1

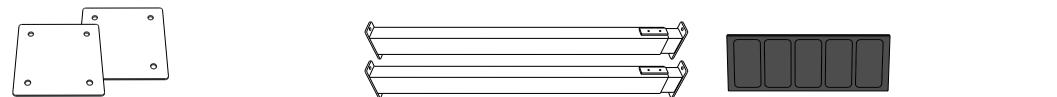

Mending Plate x2 Crossbar x2 Noise Attenuation Pads

ELECTRIC PARTS

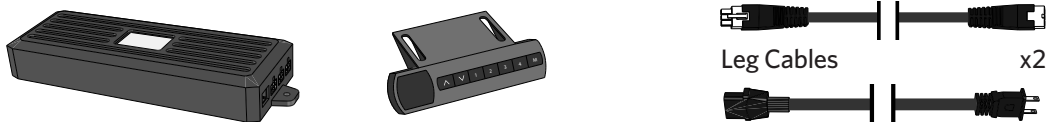

Control Box x1 Memory Handset x1 Leg Cables x2 Power Cable x1

HARDWARE

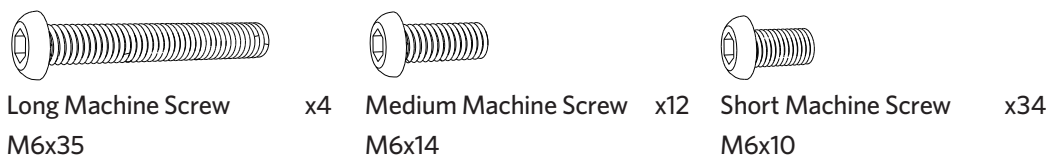

Long Machine Screw M6x35 x4 Medium Machine Screw M6x14 x12 Short Machine Screw M6x10 x34

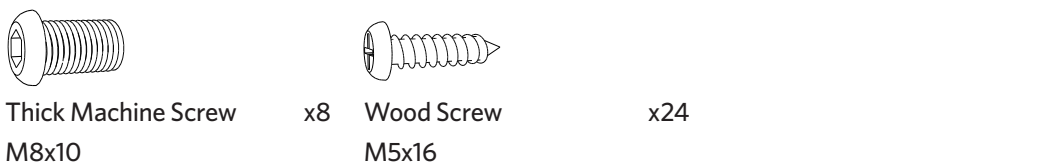

Thick Machine Screw M8x10 x8 Wood Screw M5x16 x24

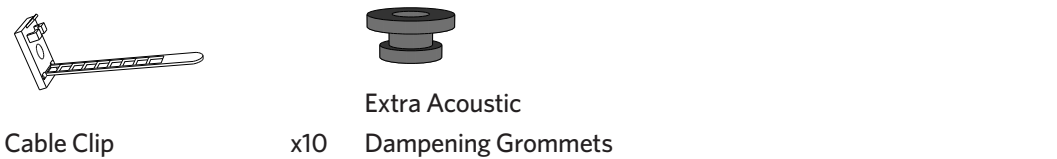

Cable Clip x10 Extra Acoustic Dampening Grommets

Assembly

STEP 1

Before assembling your desk, we find it helpful to choose how you'd like your desk oriented, and decide whether you'd like the Memory Handset to be mounted on the left or the right.

Lay your Desk Top on a padded workspace, top down, in the shape of an L. If you'd like the desk top to form an L to your left once built, align the smaller piece on the right side during assembly, and vice versa.

We know this can be difficult to wrap your head around! Don't worry, we made pictures to help.

A. Handset on left, small desk top on left

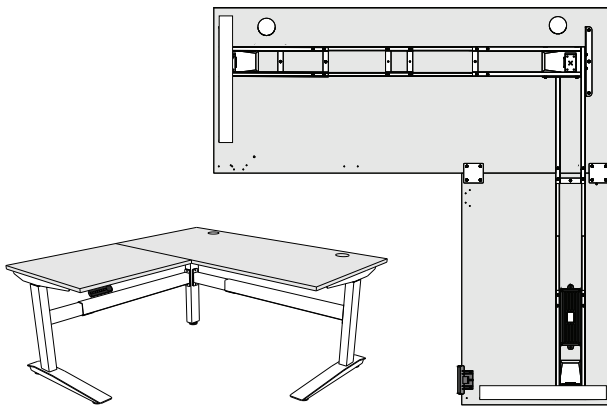

B. Handset on right, small desk top on left

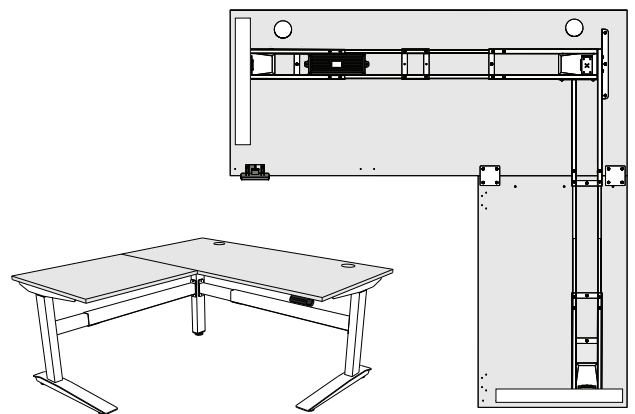

C. Handset on left, small desk top on right

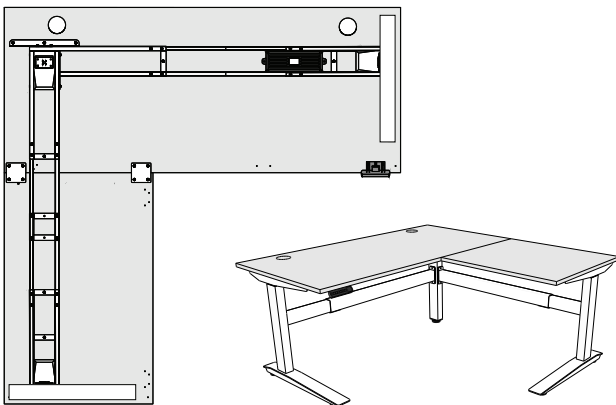

D. Handset on right, small desk top on right

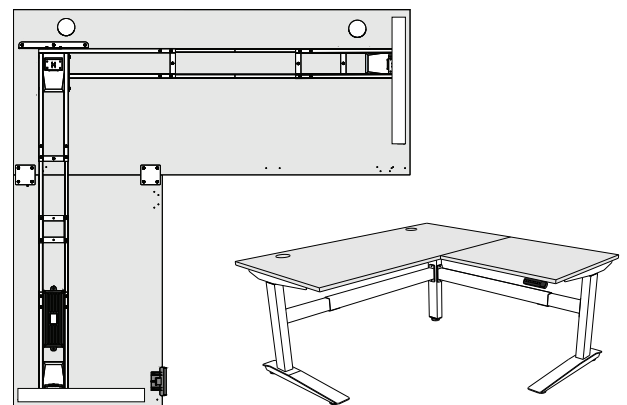

Now that you've chosen your orientation, decide which side you'd like your Handset on.

Keep in mind that a Handset placed on your left during assembly will be on the right once the desk is flipped over, and vice versa.

These instructions will follow the assembly of a desk with the smaller desk top on your left, and the handset on the right, mounted to the larger desk top (Configuration B). We'll point out any steps where you'll need to pay extra attention and make adjustments for other orientations.

STEP 2

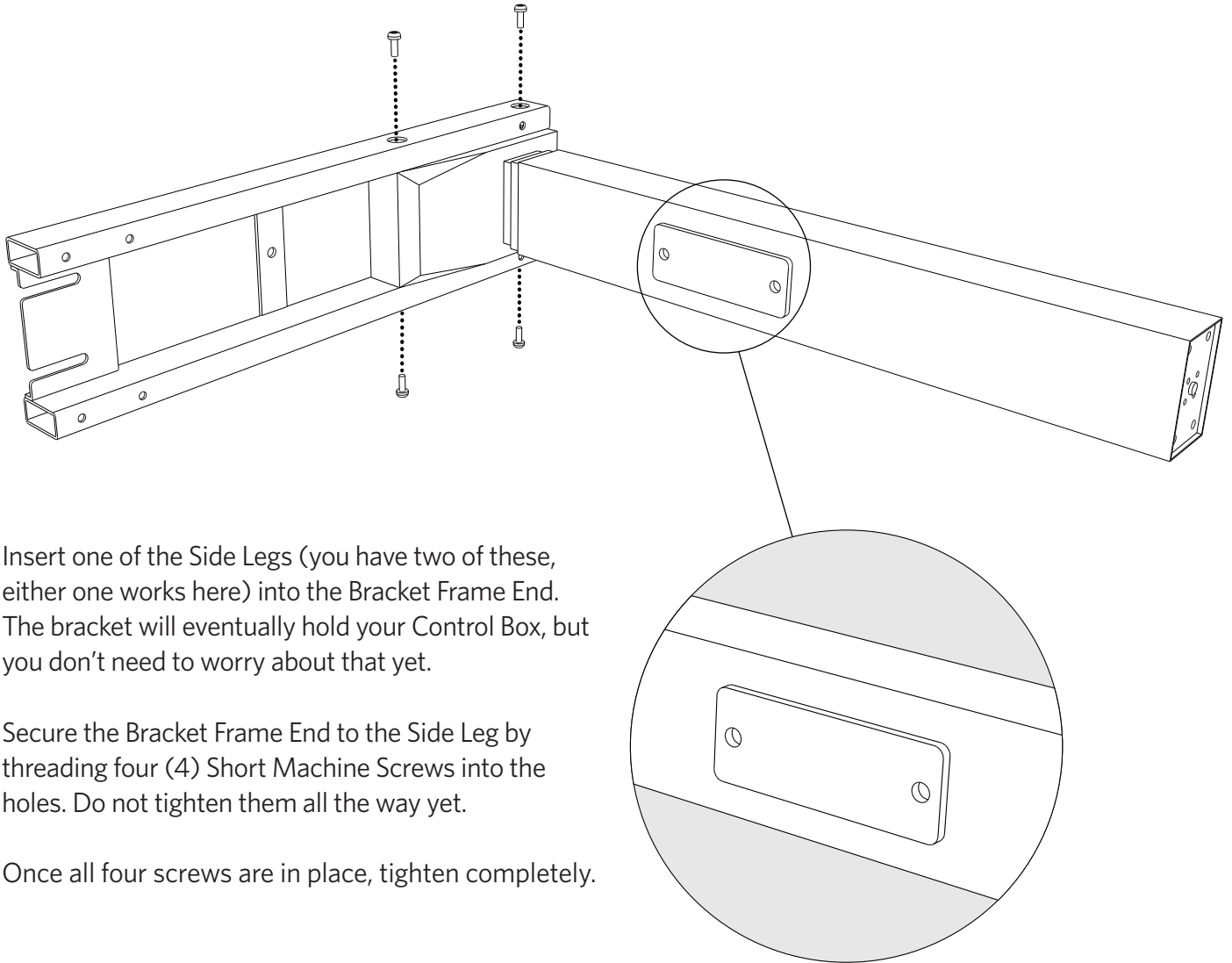
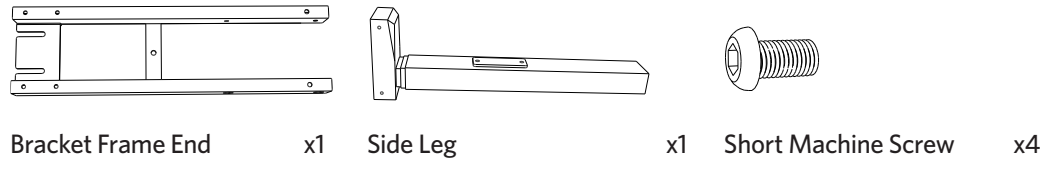

Insert one of the Side Legs (you have two of these, either one works here) into the Bracket Frame End. The bracket will eventually hold your Control Box, but you don't need to worry about that yet.

Secure the Bracket Frame End to the Side Leg by threading four (4) Short Machine Screws into the holes. Do not tighten them all the way yet.

Once all four screws are in place, tighten completely.

Note: Each Side Leg has only one crossbar mounting plate.

STEP 3

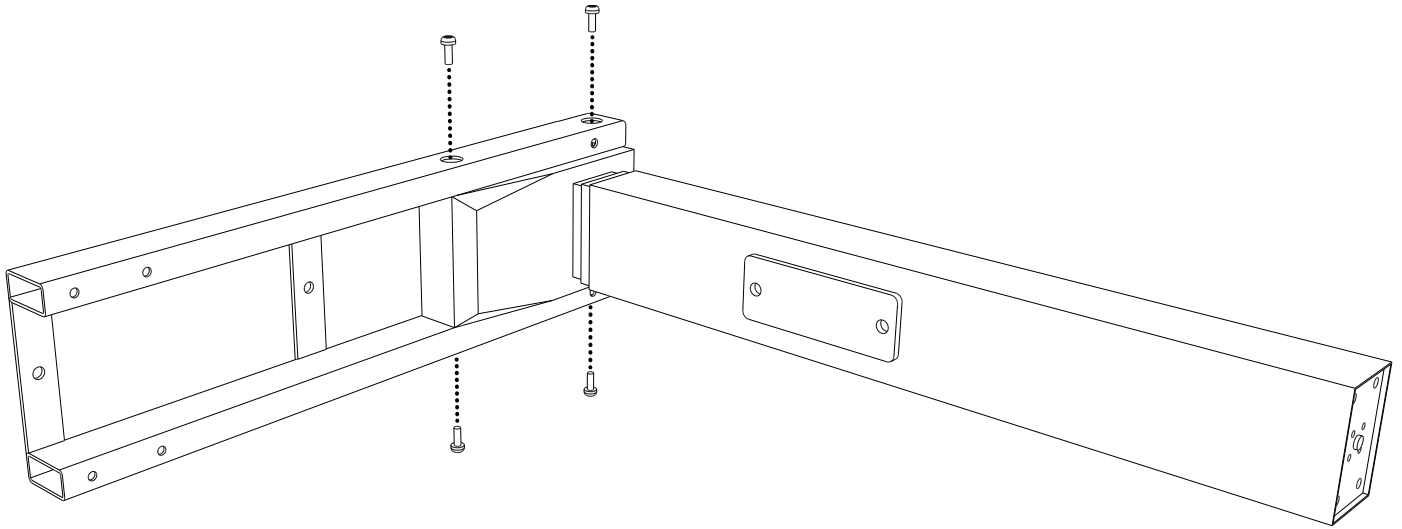
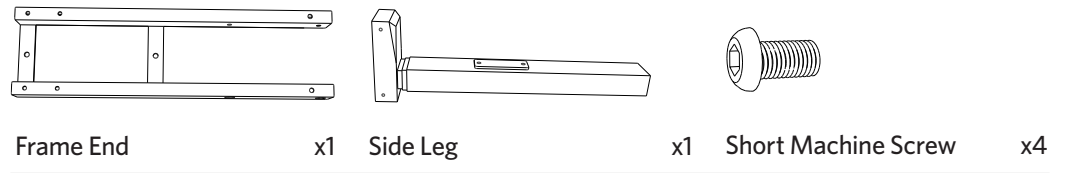

Insert the remaining Side Leg into the Frame End.

Thread four (4) Medium Machine Screws into the holes. As before, don't tighten all the way until all four screws are in place.

STEP 4

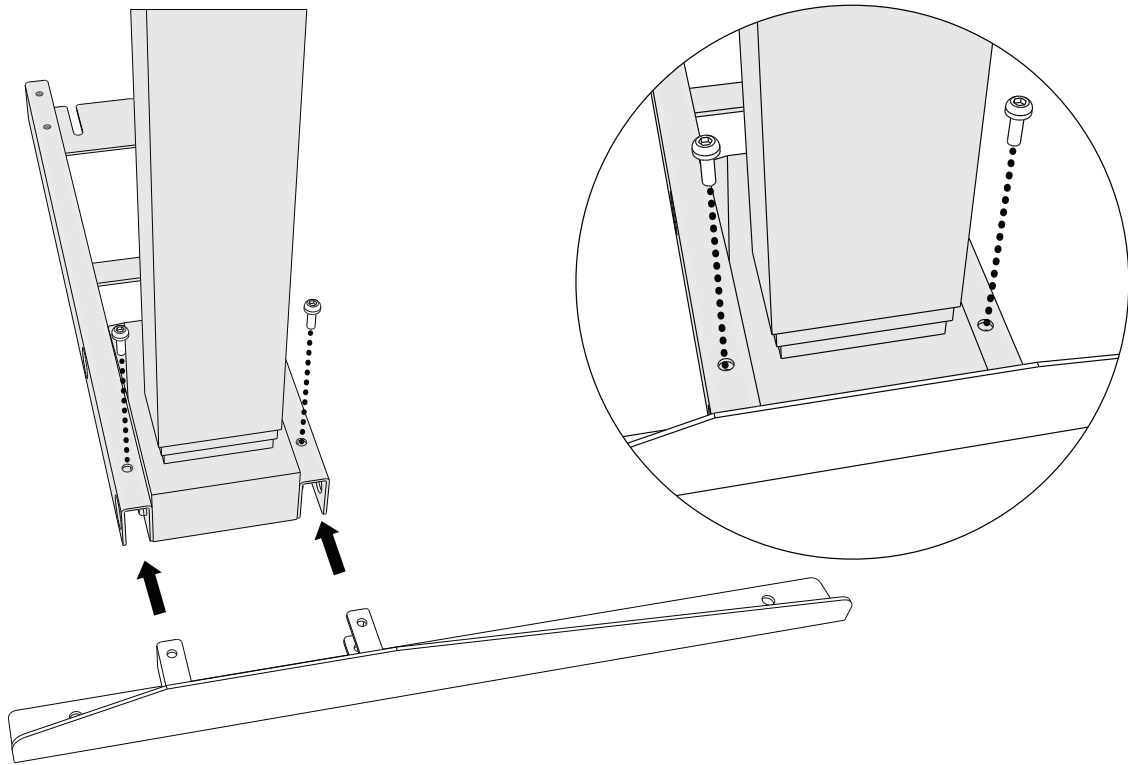
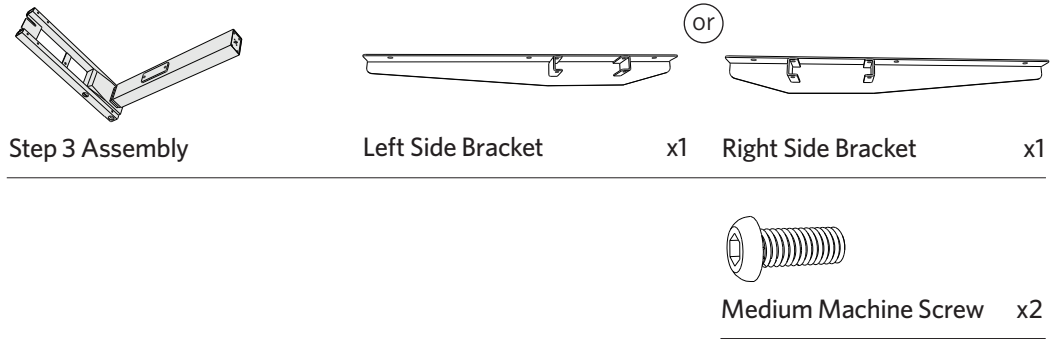

Select the Side Bracket that corresponds with your chosen Handset placement. If you'd like your Handset on the left, use the Left Side Bracket here; for the right side, choose the Right Side Bracket. Our illustration shows the Right Side Bracket.

(Revisit the Desk Orientation Illustration on page 4 if you need help picturing what this looks like once assembled.)

Grab the assembly from Step 2—the one with the Side Leg attached to the Bracket Frame End.

The two tabs on the Side Bracket will slot into the Frame End, on either side of the Leg. Use two (2) Medium Machine Screws to attach the Side Bracket to the Bracket Frame End.

As before, wait until both screws are in place before tightening completely.

STEP 5

Repeat Step 4 to attach the Side Leg and Frame End assembled in Step 3 to the remaining Left or Right Side Bracket.

STEP 6

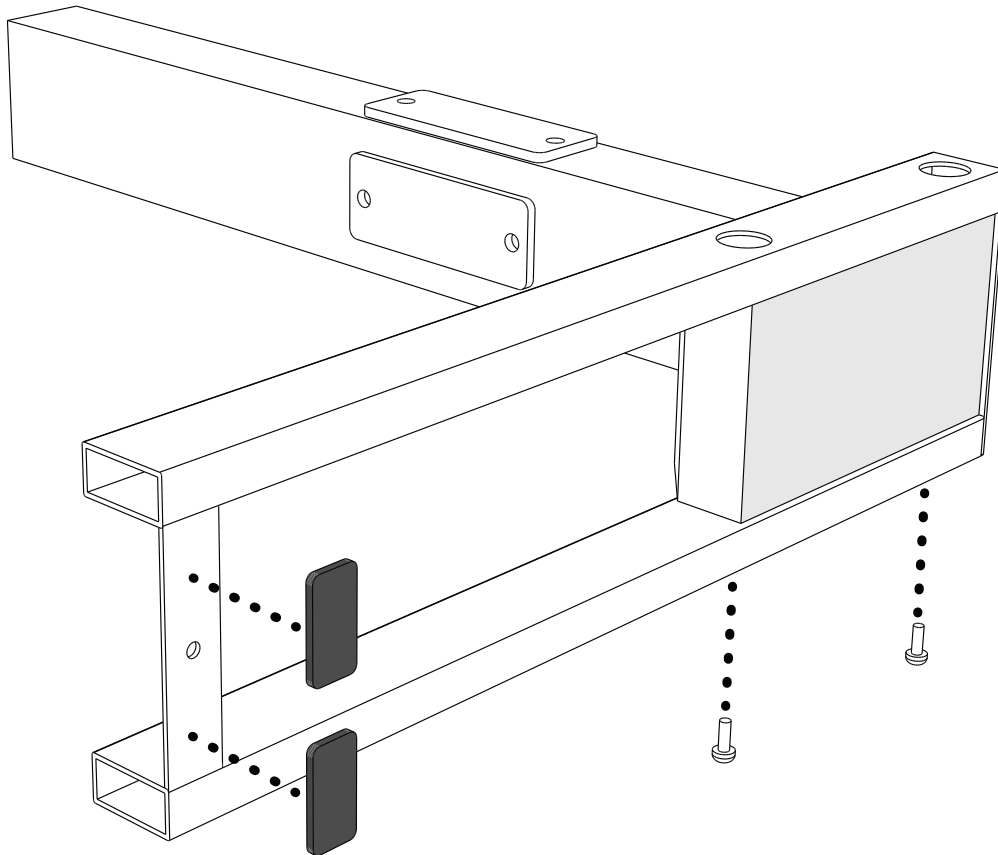
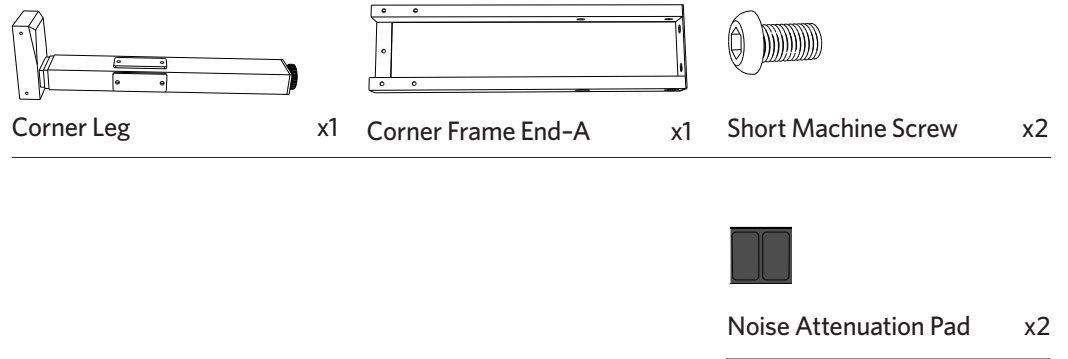

Apply two Noise Attenuation Pads to Corner Frame End-A, avoiding the screw hole.

Insert the Corner Leg into the Corner Frame End-A.

Attach the Middle Frame End to the Center Leg by inserting two (2) Short Machine Screws into the holes on the side of the leg without a crossbar mounting plate.

Thread both screws, but do not tighten completely.

STEP 7

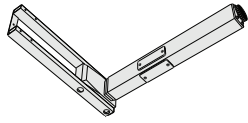

Step 6 Assembly

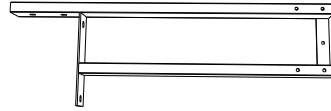

Corner Frame End-B

x1

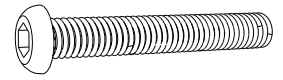

Long Machine Screw

x2

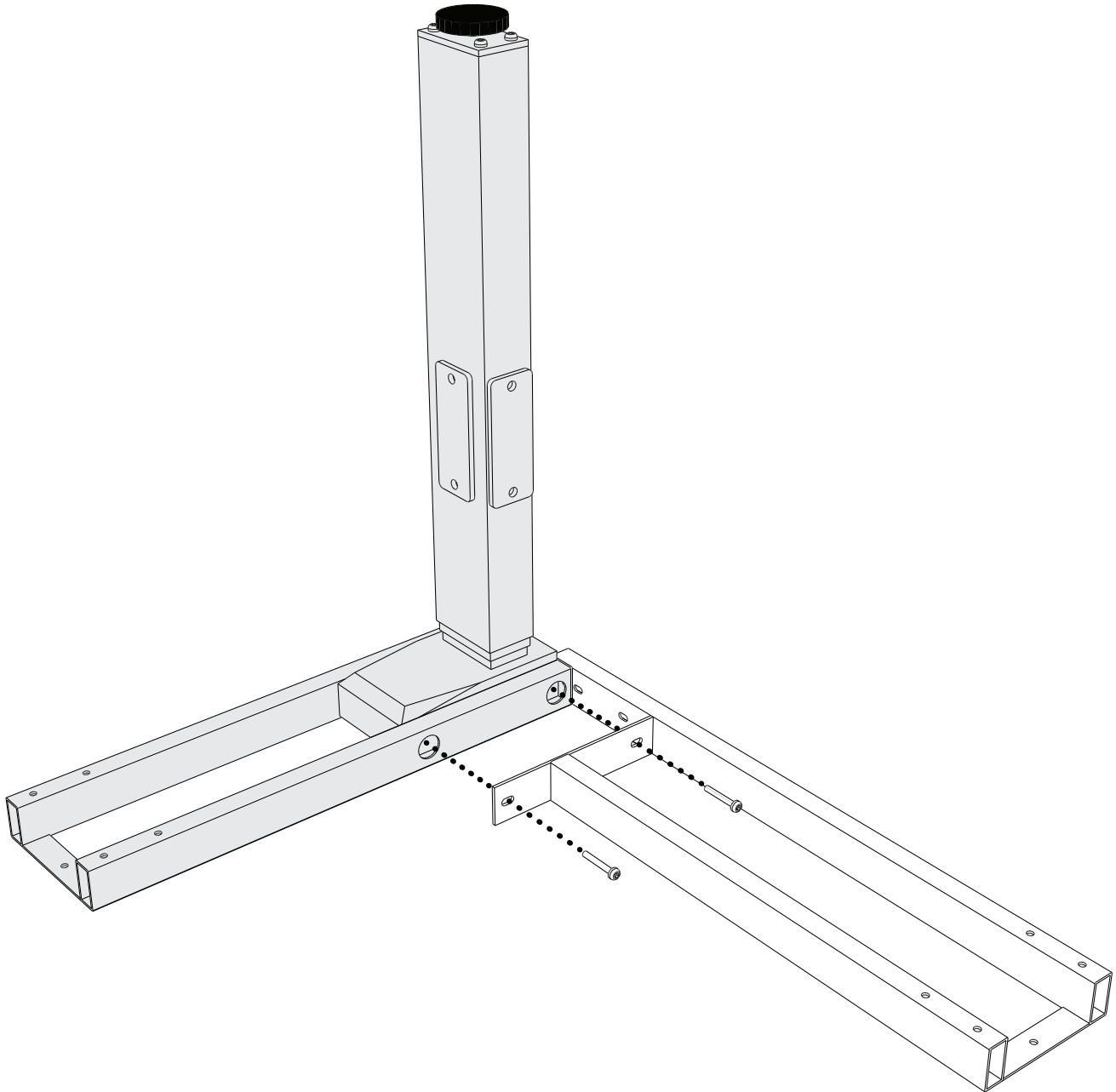

Attach the Corner Frame End-B to the Corner Leg Assembly from Step 6 with two (2) Long Machine Screws.

Now tighten all the screws from Steps 6 and 7.

STEP 8

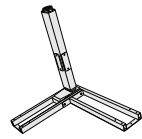

Step 7 Assembly



Corner Bracket

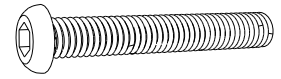

x1 Long Machine Screw x2



Noise Attenuation Pad x2

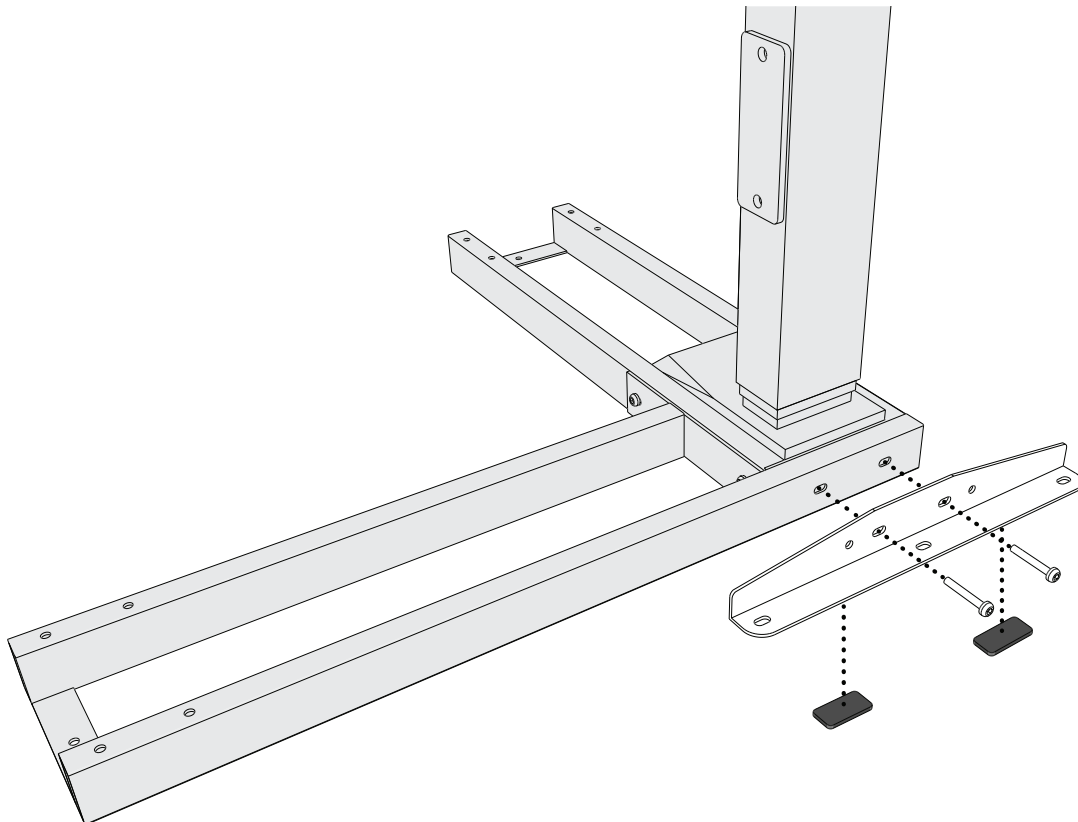

Apply two (2) Noise Attenuation Pads between the three screw holes on the Corner Bracket.

Use two (2) Long Machine Screws to attach the Corner Bracket to the outer edge of the Corner Leg Assembly.

Wait until both screws are in place before tightening completely.

STEP 9

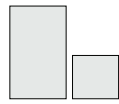

Large and Small Desk Tops

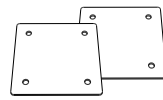

Mending Plate

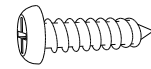

x2 Wood Screw

x8

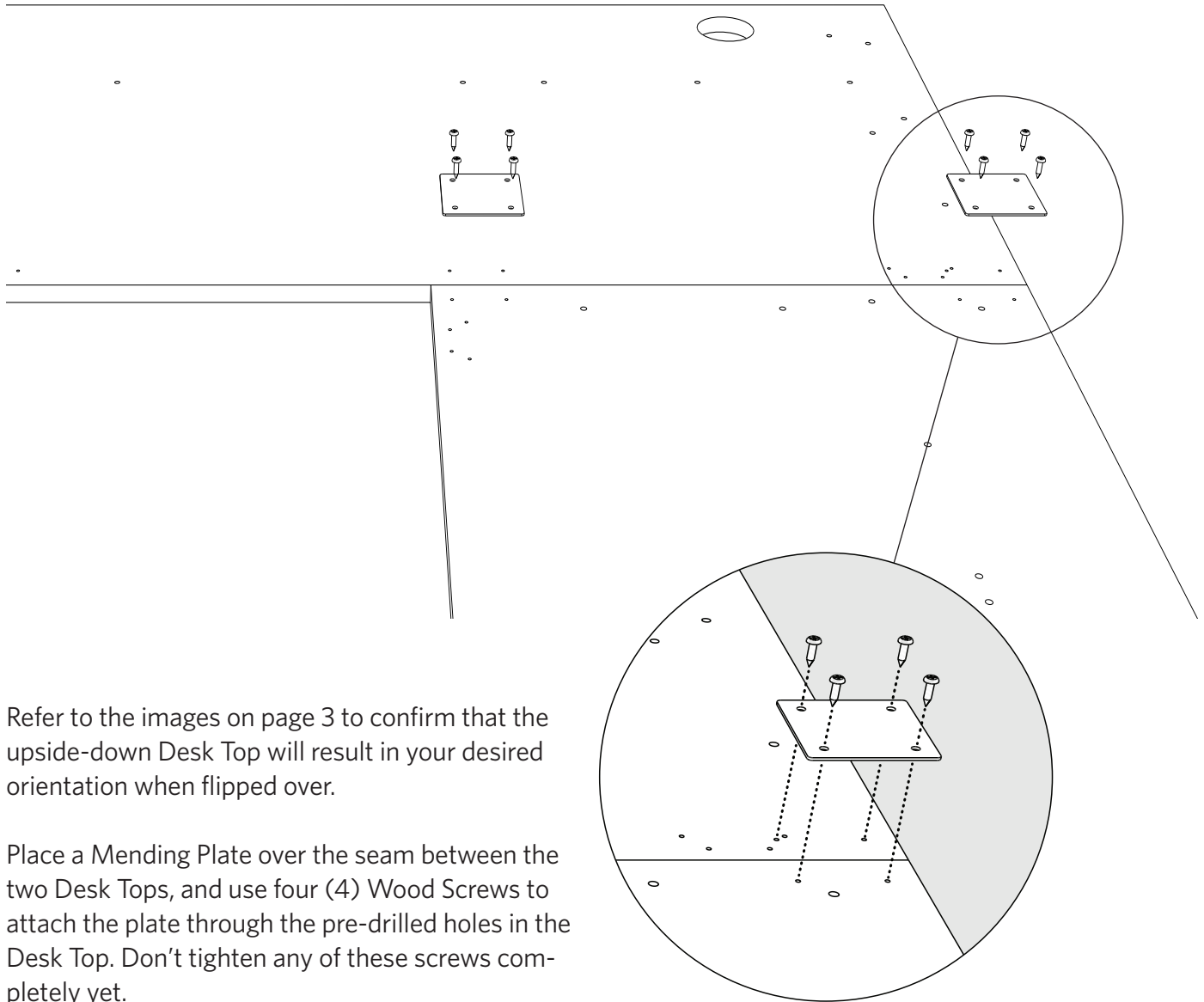

Refer to the images on page 3 to confirm that the upside-down Desk Top will result in your desired orientation when flipped over.

Place a Mending Plate over the seam between the two Desk Tops, and use four (4) Wood Screws to attach the plate through the pre-drilled holes in the Desk Top. Don't tighten any of these screws completely yet.

Repeat with the second Mending Plate. Once both Plates and all eight (8) Wood Screws are in place, tighten the Screws completely.

Note: The Desk Tops should fit tightly together when the Mending Plates are aligned with the correct set of pre-drilled holes.

STEP 10



Side Leg Assembly

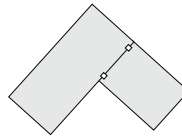

Desk Top

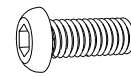

Desk Top Machine Screw x4

or

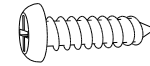

Wood Screw x4

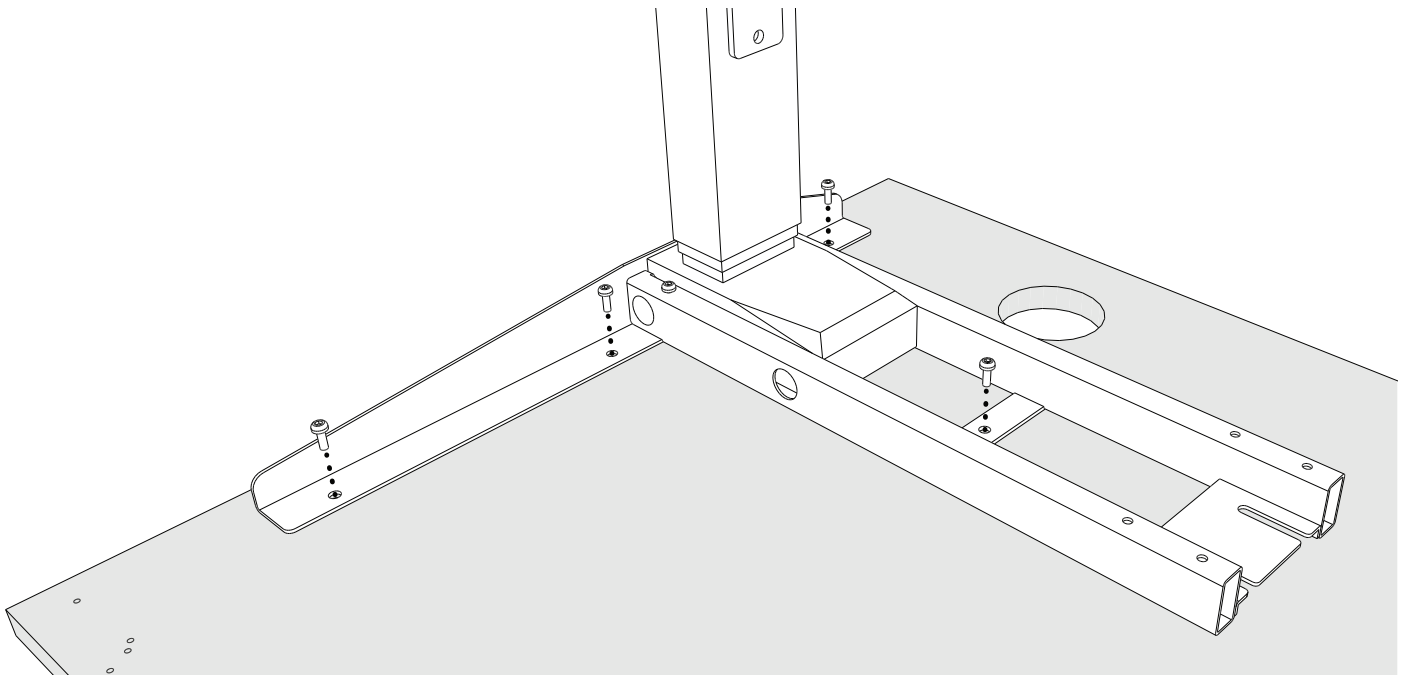

Locate the Side Leg Assembly that includes the Bracket Frame End (from Step 4). Next you'll attach it to the Desk Top on the side where you want the Handset to be installed.

In our example, we're installing the Handset on the right side of the desk, (with the smaller top to the left) so this Side Leg will be attached to the larger Desk Top. (Revisit the desk orientation illustration on page 3 if you need to!)

Place the Side Leg Assembly onto the Desk Top on the desired side, with the Bracket Frame End pointing towards the center of the desk. Attach the Side Leg Assembly to the Desk Top using four (4) screws.

Thread all four (4) screws into place, then tighten completely.

Pro Tip: If you have one of our tops with the threaded screw inserts, you'll use the Machine Screws that came packaged with the desk top. Otherwise, use the Wood Screws that came with your frame.

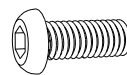

Use if desk top has threaded inserts.

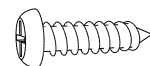

Use if desk top does not have threaded inserts.

STEP 11

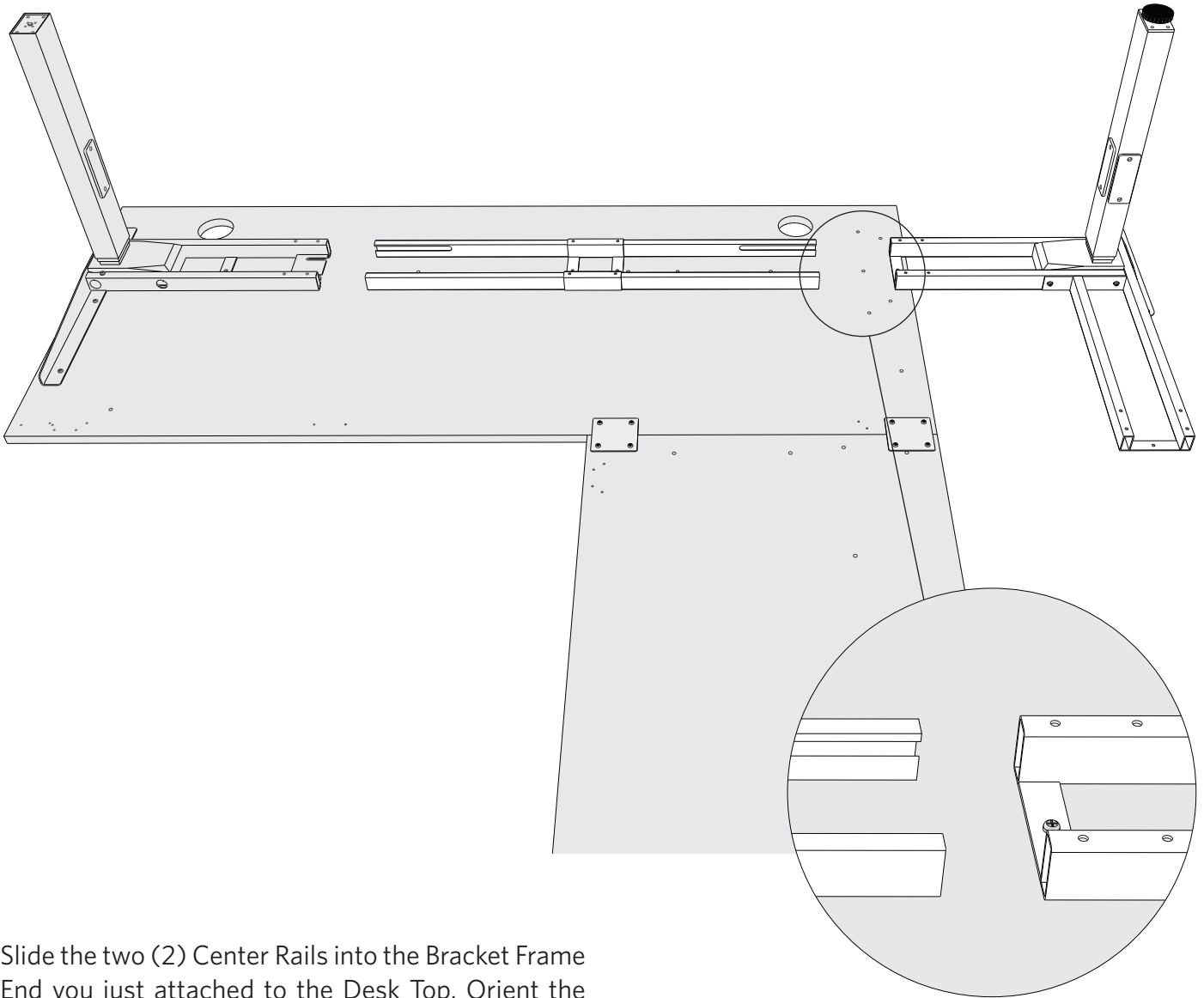
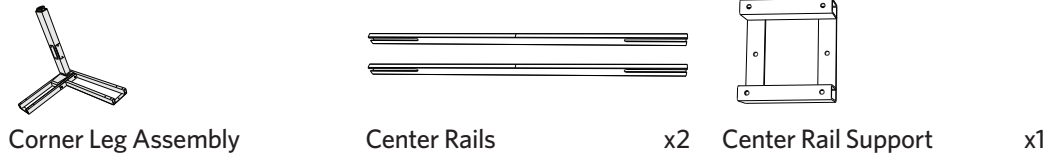

Center Rail orientation

Slide the two (2) Center Rails into the Bracket Frame End you just attached to the Desk Top. Orient the Rails so the cut-out slots face each other, and are on the top side of the Center Rails, as shown.

Slide the Center Rail Support halfway down the Center Rails, covering the marks in the middle of the Center Rails. The Center Rail Support does not need to be screwed to the Desk Top—it will be locked to the Center Rails later.

Slide the Corner Leg Assembly onto the other end of the Center Rails.

Trade Secret: The Center Rail Support adds extra support for the larger of the two tops. If you're assembling your desk in orientation A or D (see page 3), you will need to add this in Step 13 instead.

If your largest top is smaller than 72", you may leave this part off. There's no harm in using it anyway, unless your top is so small that you don't have room for it.

STEP 12

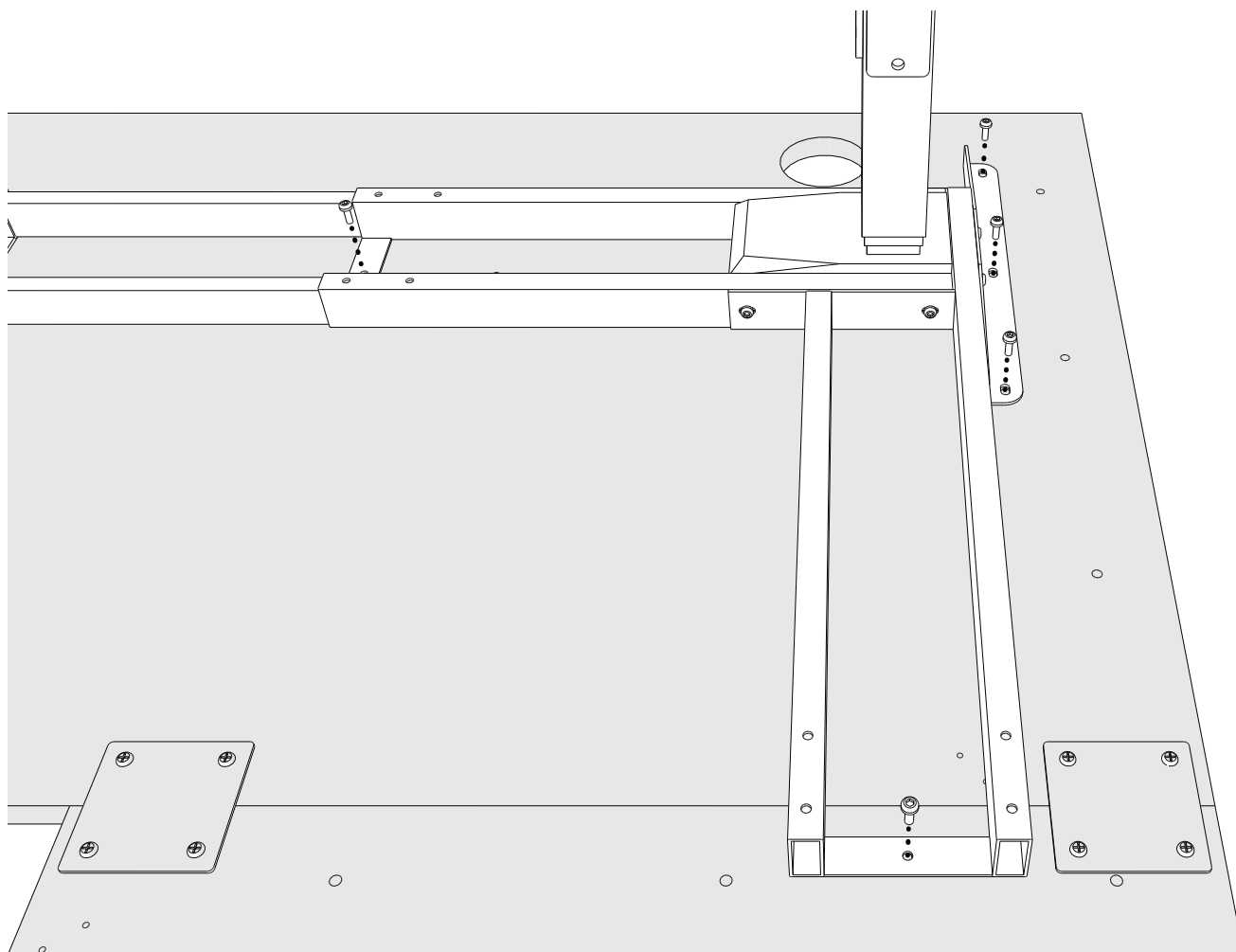
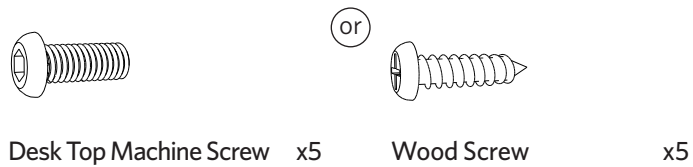

Use five (5) screws to attach the Corner Leg Assembly to the Desk Top.

Insert all screws part way before tightening them completely.

STEP 13

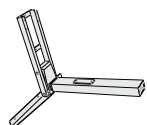

Side Leg Assembly

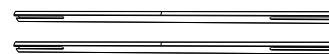

Center Rails

x4

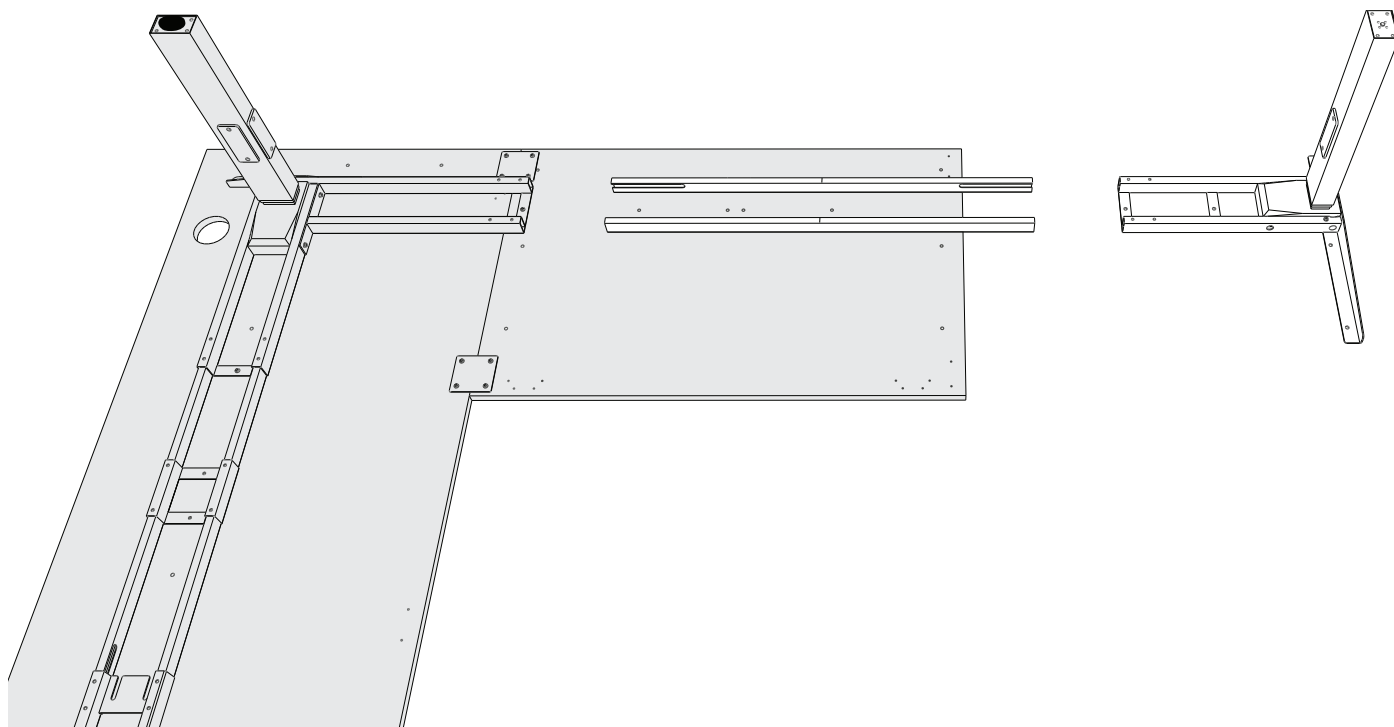

Slide the remaining two (2) Center Rails into the Corner Frame End attached to the Desk Top. Again, you'll orient the Center Rails so the cut-out slots face each other and are on the top side of the Rails.

Slide the final Side Leg Assembly onto the other end of the Center Rails.

Reminder: If you're attaching the second leg to your large top at this point, as in orientations A and D (see page 3), now is the time to add your Center Rail Support.

STEP 14

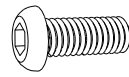

or

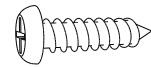

Desk Top Machine Screw x5

Wood Screw

x5

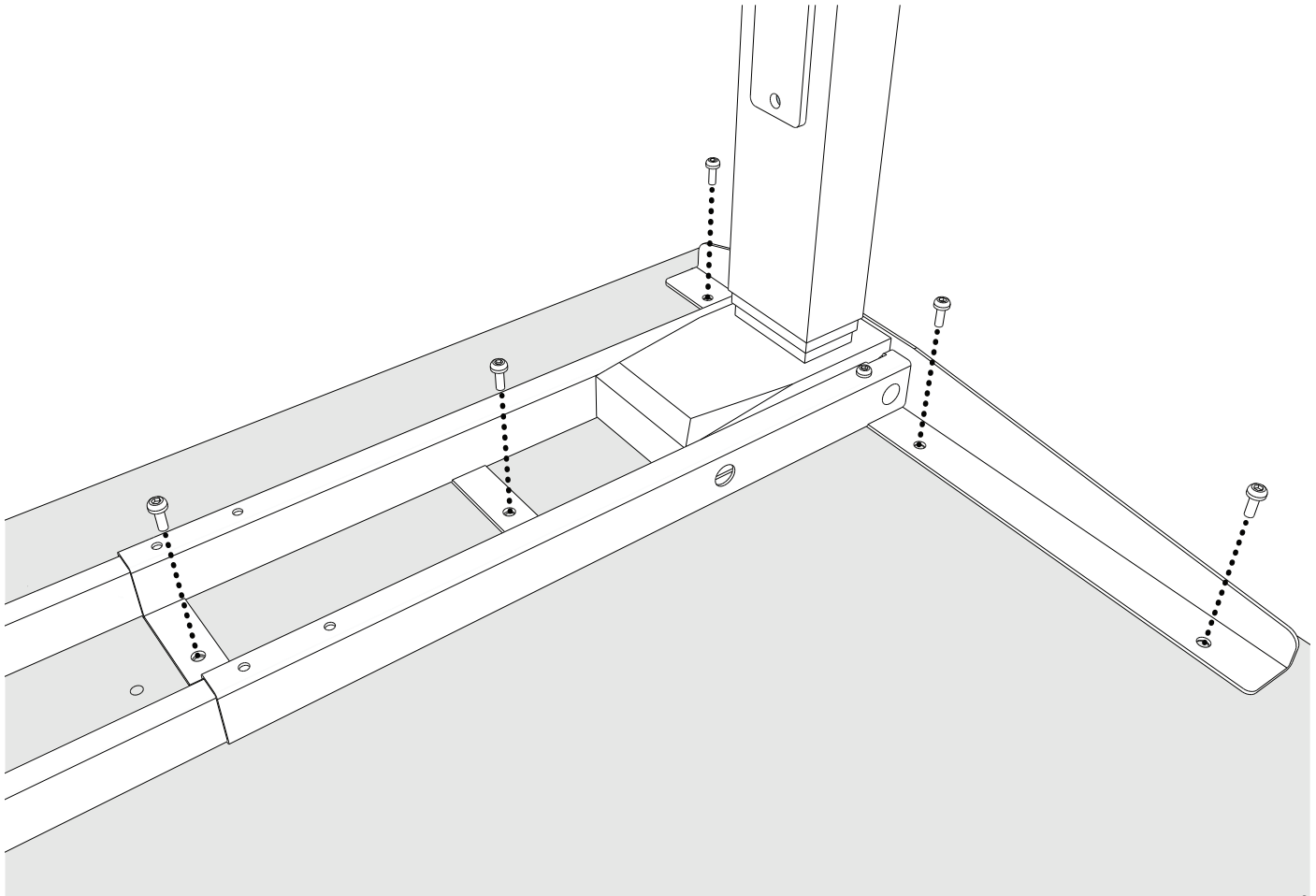

Secure the final Side Leg Assembly with five (5) screws.

Thread all screws part way. Once they are in place, tighten them completely.

STEP 15

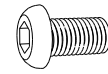

Short Machine Screw x20

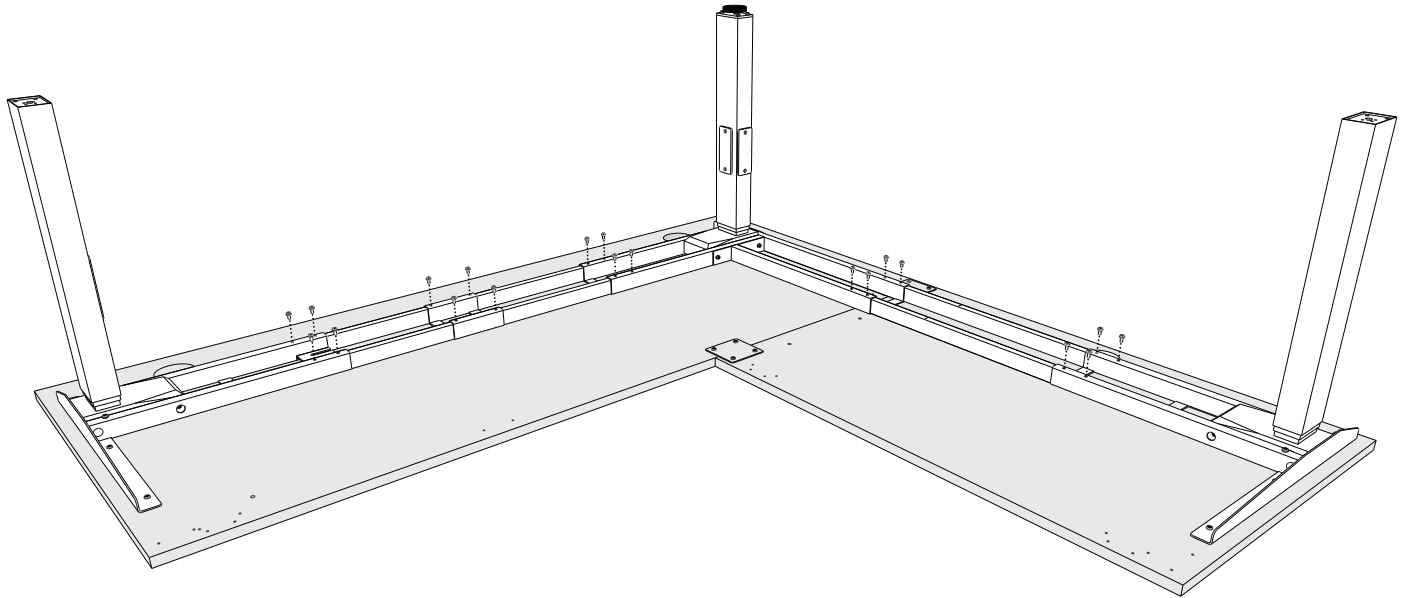

Center both pairs of Center Rails between the Frame Ends.

Warning: It might be tempting to skip this step. But don't! Doing so will result in stability issues.

Use twenty (20) Short Machine Screws to lock the Center Rails down firmly. This will turn the frame into a single unit, and provide support for the parts of the tabletop between the legs.

If you've omitted the Center Rail Support, you'll only use 16 screws.

STEP 16

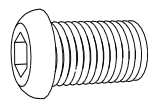

Thick Machine Screw

x8

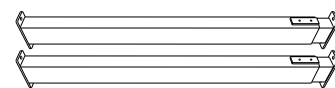

Crossbar

x2

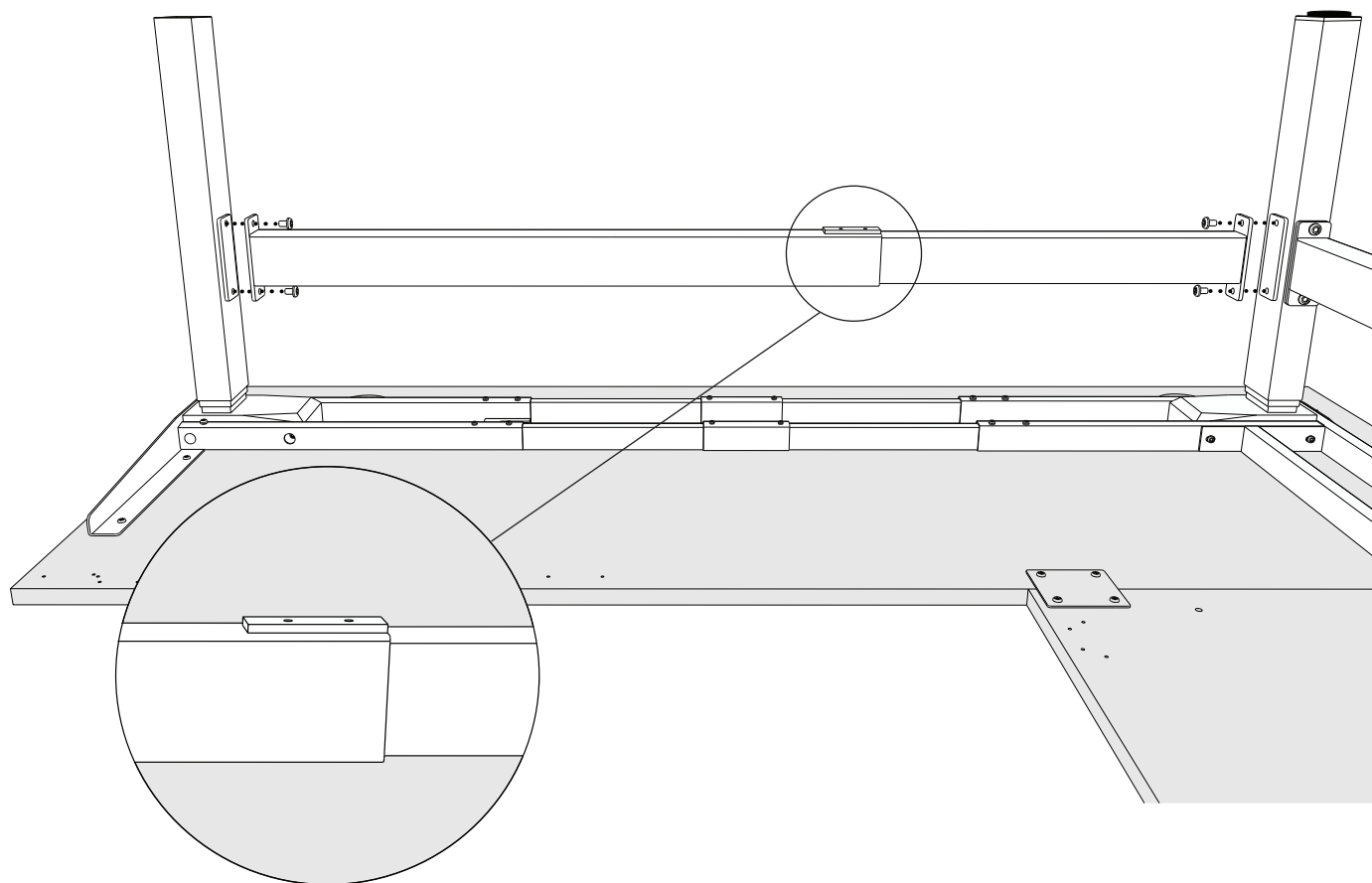

Install both Crossbars to the mounting plates on the Side and Center Legs, adjusting the width to meet each plate.

It doesn't matter which Crossbar end goes left or right, but you do want the center screw plate facing up.

Once all screws are in place on both Crossbars, tighten them completely.

Pro tip: We find it easiest to start by partly threading both top Thick Machine Screws into place before installing the bottom screws.

STEP 17

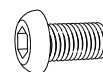

Short Machine Screw x4

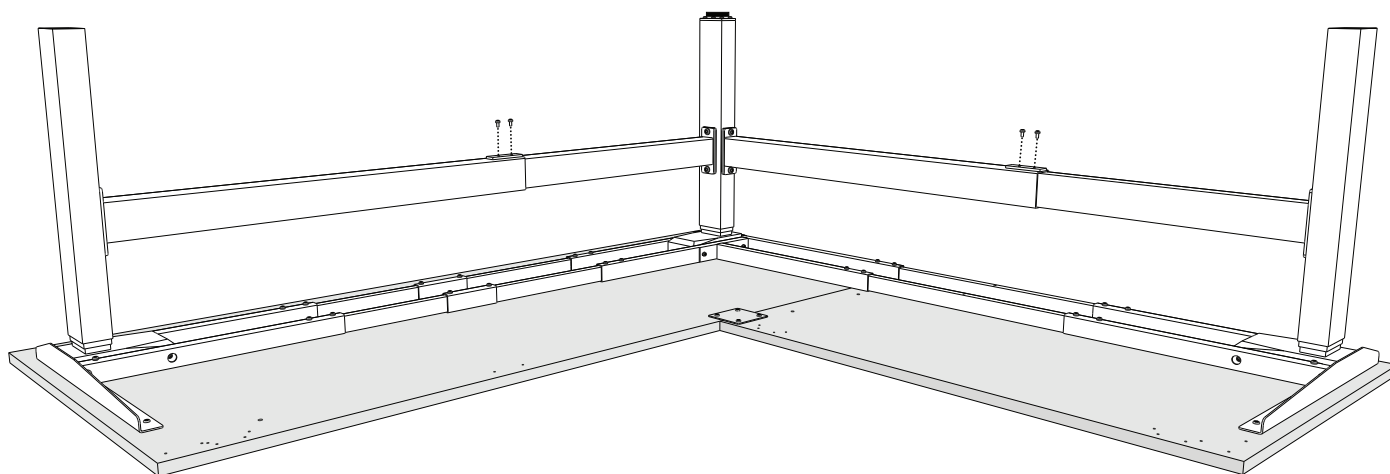

Use four (4) Short Machine Screws to fix the Crossbars in place.

STEP 18



Memory Handset



x1 Wood Screw x2

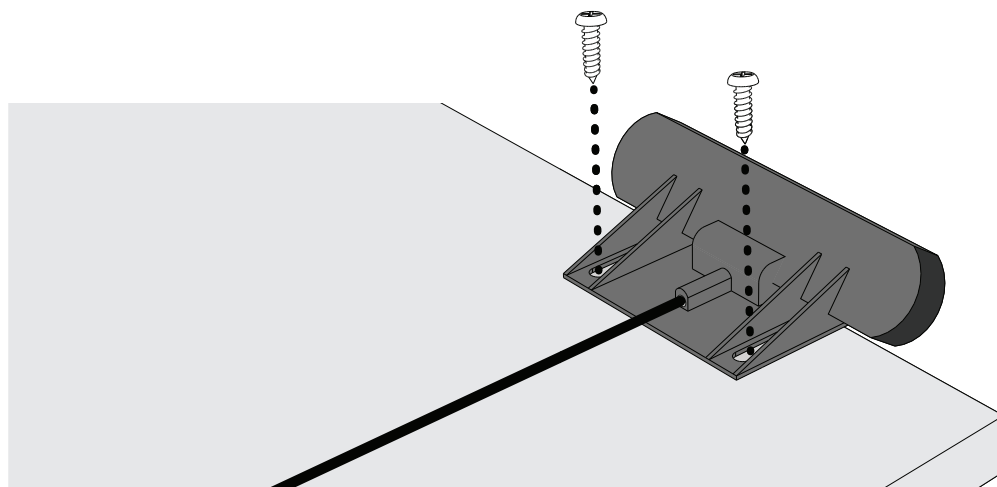

It's time to install your Handset.

If you're using a Jarvis Desk Top, there will be pre-drilled holes on both the left and the right sides for attaching your Handset. These holes will not have threaded inserts.

Using two (2) Wood Screws, secure your Handset to the Desk Top.

STEP 19

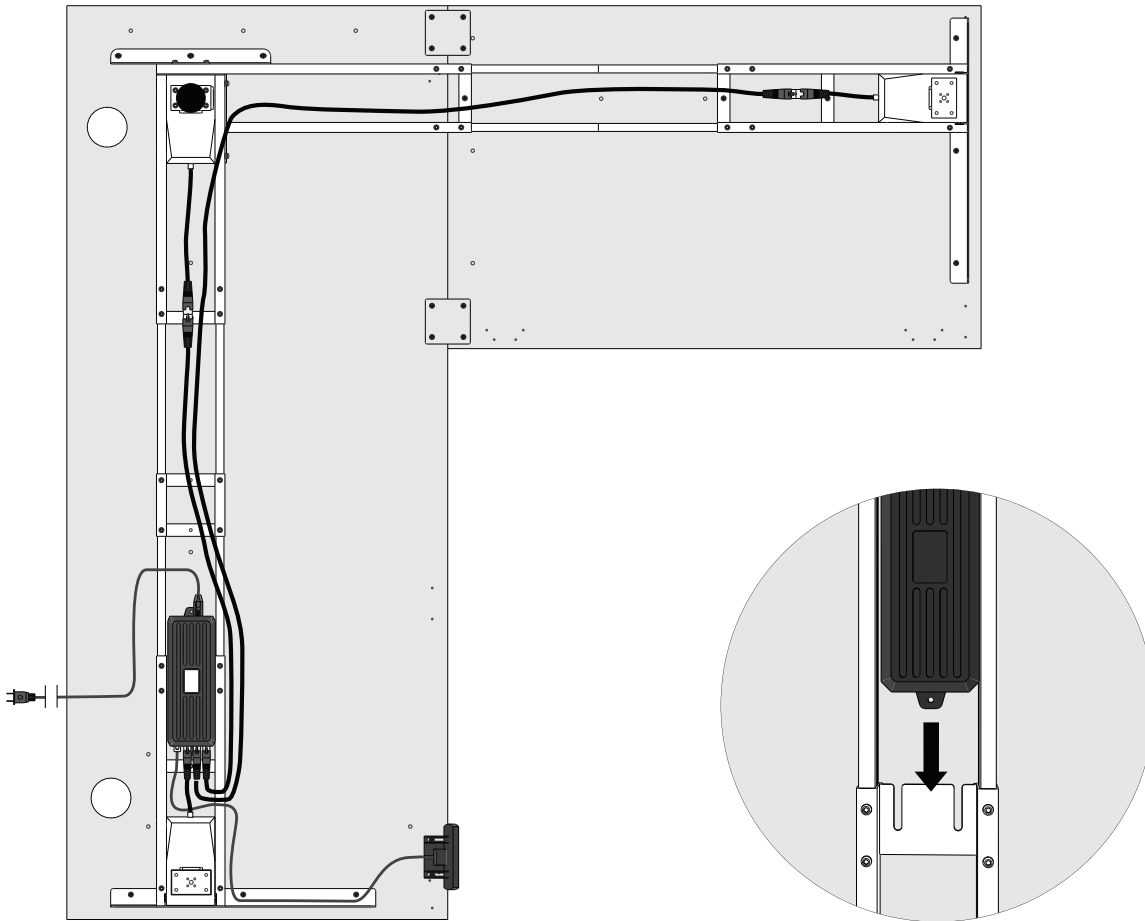
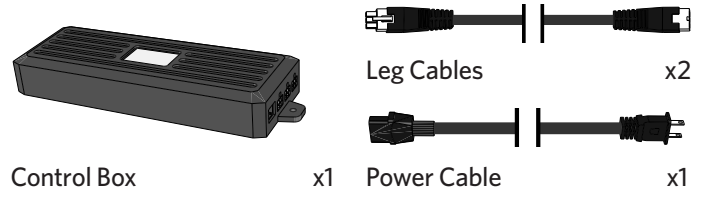

Slide the Control Box onto the Control Box Bracket on the Bracket Frame End. The “M” sockets should face the closest leg.

Plug the cable from the closest leg directly into socket M1 on the Control Box. Use the Short and Long Leg Cables to connect the other two legs to the Control Box via the M2 and M3 sockets.

Connect the Handset to the Control Box using the socket labeled HS.

Connect the Power Cable to the Control Box using the socket labeled AC.

Pro Tip—Cable Management: Cable Clips work best when they are adhered directly to the metal Jarvis frame, rather than the desk top. Plus, it just looks cleaner.

Route your Power Cable towards the side of your nearest wall outlet, or use a cable management tray for optimal cable taming goodness.

STEP 20

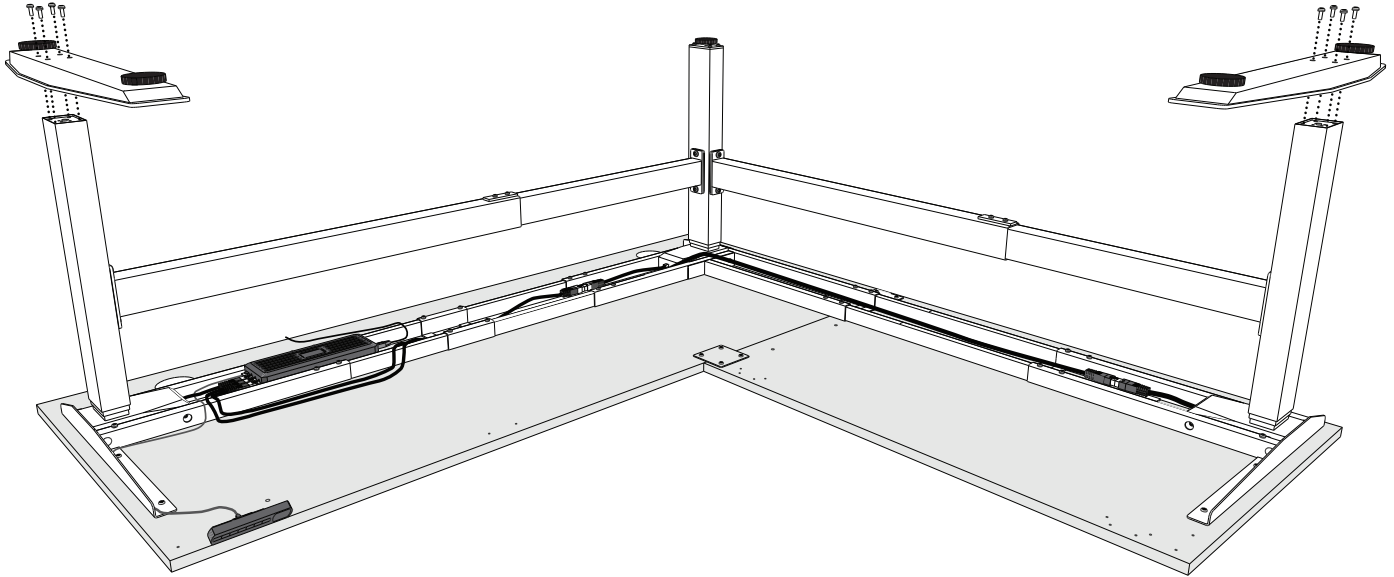
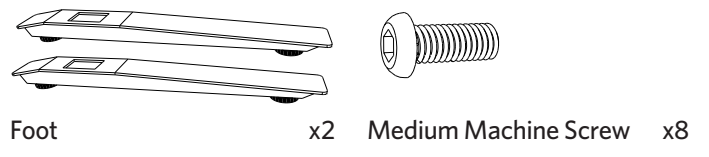

Loosely attach a Foot to one of the Side Legs using four (4) Medium Machine Screws. Once all screws are in place, tighten them completely, working in an X pattern.

Repeat to attach the other Foot to the other Side Leg.

If you are planning to use Braking Casters with your Jarvis Desk, remove all five Leveling Glides from the feet and thread the Braking Casters in their place at this point.

STEP 21

Double check that all of the screws on the desk are fully tightened.

Failure to install and tighten all screws may result in instability.

STEP 22

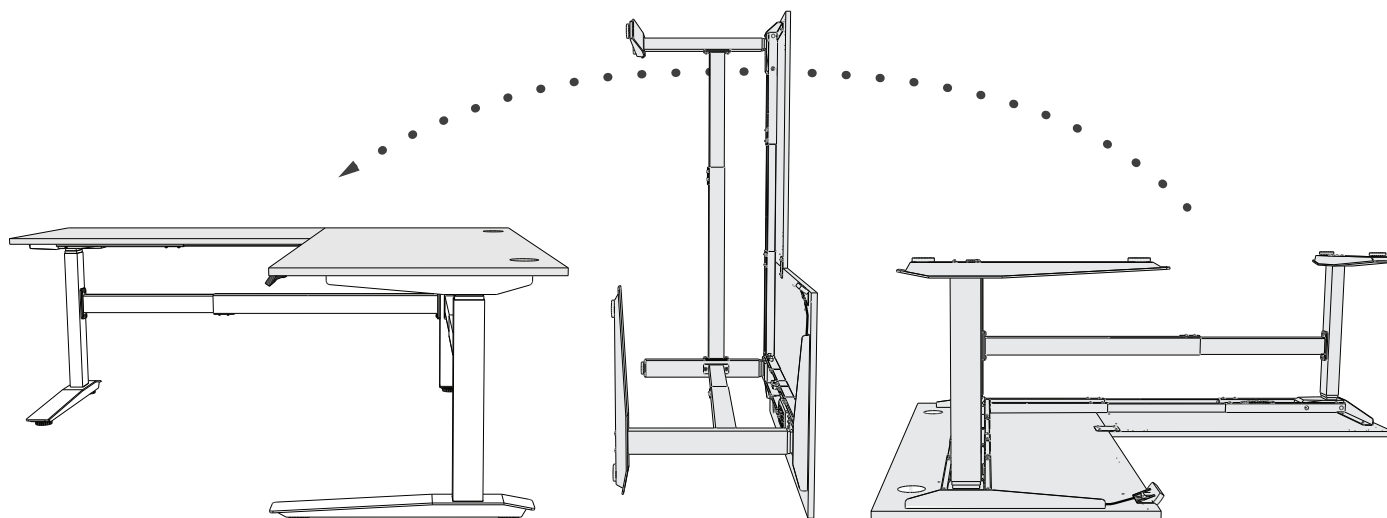

With a friend (or a few), lift the desk and gently flip it onto its feet, supporting both the top and the frame of the desk. Be careful to avoid the Handset.

If your desk sits unevenly on the floor, adjust the pre-installed leveling glides (or your swapped-in Braking Casters) on the Feet as needed by threading them further in or out.

Plug in the desk and proceed to Initial Calibration on the next page.

Setup

Initial calibration

Before you start using your desk normally, you'll need to get all the parts synced. Don't worry, it's easy.

1. Press and hold the DOWN button until the display reads RST (looks like "ASΓ"). Release.
2. Press and hold the DOWN button again, this time until the desk first lowers slightly, then rises slightly, and finally stops. Release the DOWN button.
3. You can now use your desk! See below for tips on making the most of your Memory Preset Handset.

Setting memory presets

1. Adjust the desk to the desired height.
2. Press M (the display will show S -).
3. Press a number 1-4.
4. Pressing that number will return your desk to the programmed height. By default, the desk will continue to move on its own once you've activated the preset, though pressing any other button will stop this movement. If you prefer to change this behavior, please refer to "Toggle between One Touch and Constant Touch Presets" on page 24.

Custom settings for Memory Preset Handset

Lock your desk

Your desk can be locked in place at any height, either as a safety precaution, or just to keep your friends from messing with your settings. It unlocks just as easily, but we recommend guarding that secret.

To lock: Press and hold the M button for about 8 seconds. The display will first change to S -, then to LOC, indicating that the desk is now locked.

To unlock: Press and hold the M button for about 8 seconds until LOC goes away and the height appears on the display.

Adjust the height readout

Our LED handsets display the approximate height of your desk top surface, in inches or centimeters.

The accuracy may be affected by the thickness of your top, the evenness of your floor, etc. If you want it to be completely accurate, you can manually set the readout to match your measured height.

1. Press and hold the DOWN button until the desk reaches its lowest position. Release.
2. With your favorite measuring tool, measure the distance from the floor to your desk top surface. If it matches your readout, you're all set. Otherwise, proceed to the next step.
3. Press and hold the DOWN button again, until the display flashes RST (looks like "ASΓ"). Release.
4. Press and hold the M button until it begins to flash the starting height. Note: the display will revert to RST after about 5 seconds. If that happens before you have a chance to make your changes, just press and hold M again

To change the readout height:

1. Use the UP or DOWN button to adjust the display by 0.1 inch at a time until the display shows the correct height, as measured.
2. Wait about 5 seconds and the display will automatically return to RST, which indicates Reset Mode.
3. Complete the reset process by pressing and holding the DOWN button again while the desk lowers a little bit more, slightly rises, and then stops.
4. Release the button, and you should see the new starting height ± 0.1 inches. This height is saved, and your desk is ready to use!

Set custom upper and lower height limits

By default, the Jarvis frame and handset are set to allow the maximum range of motion, from a fully retracted Lifting Column, to a fully extended one. If you would like to set a higher minimum height, or a lower maximum height, you can do that! Before starting, make sure the desk is plugged in, and the LED display is showing a number. If the readout has gone dark, you can wake it up by pushing any button. If it is displaying something besides a number, perform the Reset Procedure on page 25.

To set the upper limit:

1. Use the UP/DOWN buttons to move the desk to the desired maximum height.
2. Press the M button and release, then press the UP button and release. The display will flash S - to show that it is ready to set the upper limit.
3. Press and hold the M button for about 2 seconds. The display will show "999" and then return to the height readout. This indicates that the upper limit is set. All done!

To set the lower limit

1. Use the UP/DOWN buttons to move the desk to the desired minimum height.
2. Press the M button and release, then press the DOWN button and release. The display will flash S - to show that it is ready to set the lower limit.
3. Press and hold the M button for about 2 seconds. The display will show "000" and then return to your selected height. This indicates that the lower limit is set. You did it!

Warning: There are certain times when your desk might require a Reset Procedure to correct a balance, calibration or other issue. This procedure requires the legs to retract completely, beyond any lower height limits that might be set. Please ensure that you have the proper clearance below the desk base.

Note: If you had previously set any memory presets that were outside of your newly defined range, they won't work anymore. You can reuse the numbers.

2nd Note: If you want to set a new upper or lower limit that is outside of your set range, you will first have to restore the defaults.

To restore default upper and lower limits

1. Press the M button and release. "S -" will appear on the display.
2. Within 5 seconds, press the M button again and hold for about 2 seconds until the display shows "555".
3. Release the button. The display will automatically change back to the height display, and your height limits are no more.

Toggle between One Touch and Constant Touch presets

Your programmable handsets allow your desk to remember your favorite height settings. By default, if you press and release a memory preset button, the desk will move on its own to the programmed height. You can change this behavior so that the desk will only continue to move to the programmed height with continued pressure on that preset number. Here's how to toggle this setting:

1. Press and hold the DOWN button until the desk reaches its lowest position. Release.
2. Press and hold the DOWN button again, until the display begins to flash RST (looks like "ASΓ").
3. With the display still flashing RST, press and hold the 1 button for about 5 seconds. The handset will register the change in input method and display the corresponding readout:

10.1 = One Touch

The desk will keep moving to the preset height after you release the memory preset button

10.2 = Constant Touch

The desk will only continue to the programmed height while you are holding the corresponding preset button

4. To toggle to the next setting, press and hold the 1 button again for 5 seconds, until the displayed readout updates.
5. Once your preferred setting displays, release the button and wait about 5 seconds for the display to return to RST.
6. Complete the reset process by pressing and holding the DOWN button again while the desk lowers a little bit more, slightly rises, and then stops. Release the button. Your new preset touch setting is saved, and the desk is ready to use!

Change readout between inches and centimeters

By default, our programmable handsets display inches on models configured for 120-Volt power, and centimeters on models for 240-Volt power. If you'd like to break with tradition, you can easily change this setting.

1. Press and hold the DOWN button until the desk reaches its lowest position. Release.
2. Press and hold the DOWN button again, until the display begins to flash RST (looks like "ASΓ").
3. Press and hold the 2 button for about 5 seconds. Your handset will register the unit change and display the corresponding readout:

10.3 = Centimeters

10.4 = Inches

4. To toggle to the next setting, press and hold the 2 button again for 5 seconds, until the displayed readout updates.
5. Once your preferred setting displays, release the button and wait about 5 seconds for the display to return to RST.
6. Complete the reset process by pressing and holding the DOWN button again while the desk lowers a little bit more, slightly rises, and then stops. Release the button. Your preferred unit setting is now saved, and the desk is ready to use!

A note regarding the anti-collision feature

The Jarvis desk is programmed with an automatic collision detection system: If your desk is in motion, and it detects that it has run into a stationary object, it will automatically stop moving, pause briefly, and then move about one inch in the *opposite* direction before halting completely. We hope that this will prevent any of your valuable belongings from getting damaged by accident! It takes about 15 pounds (around 7 kg) of pressure to activate this feature. If you have any concerns or would like to inquire about modifying this preset, please give us a call at 888-508-3725.

Troubleshooting

If your desk is not functioning properly, or if your Memory Preset Handset that reads "RST" or any error message (E01 - E13), confirm that all wired connections are secure (legs to cables, cables to Control Box). Once you're certain that all connections are secure, perform the reset procedure on page 21. If the error message persists after the reset procedure, contact Fully.

If there is a difference in height between the two legs that exceeds 1.5", stop the reset procedure and contact Fully. If the Memory Preset Handset displays "HOT", let the desk cool down for 20 minutes.

Reset procedure

CAUTION: this will override any custom lower limit you might have set! Please ensure proper clearance for the Lifting Columns to retract fully.

1. Press and hold the DOWN button until the desk reaches its lowest position. Release.
2. Press and hold the DOWN button until the display reads RST. Release.
3. Press and hold the DOWN button again, this time until the desk first lowers slightly, then rises slightly, and finally stops. Release the DOWN button.
4. You can now use your desk!

Using your own desk top

There's no one right way to position your frame on your desktop but there are a few things you'll want to keep in mind. Generally speaking, the desktop should be centered over the frame side-to-side, and positioned slightly forward of center (towards the user) front-to-back.

Most L-shaped desktops will consist of 2 pieces: a large "main" top and a smaller "return" top on one side.

Large "Main" Top

The Jarvis L-shaped frame accommodates a large main top of 27" to 33" deep and 54.25" to 82" wide.

Small "Return" Top

The dimension limits for the smaller top are a little trickier, since they'll depend on the size and shape of your larger top. The total distance from the back edge of the large top to the front edge of the small top should be between 54.25" and 82". You can find the maximum width of the small top (the side perpendicular to the front edge of the large top) by subtracting the depth of the large top from 82". The depth of the small top (the edge parallel to the front of the larger top) should be no fewer than 27", and no more than 33".

Position over the feet

In our experience, desks have better lateral stability the further apart the legs are. We position the screw holes for the Side Brackets 2 inches in from the sides of the desktop. This leaves about 1" of desktop overhang and maximizes lateral stability.

Placing the holes at least 2 inches in from the sides lowers the chance that your desktop will split during drilling.

Depending on the rigidity and strength of your desktop material you can leave more of it overhanging the Side Brackets.

For example, on our 78" tops the Side Bracket holes are 5" in from the edge with 4" of overhang.

Laying it out

The easiest way to accurately position the Frame on the Top is to use the Frame as a guide:

1. Attach the Side Brackets to their appropriate Frame Ends (without the lifting columns).

It is best to start with the two Frame Ends you would like on the larger top:

- a. The Regular Frame End or Bracket Frame End, and
- b. The Corner Assembly from Step 8 of the Assembly Instructions.

The Corner Assembly will align with the corner of your desk where the two tops come together. See page 3 of the Assembly Instructions for reference.

2. Slide two of the Center Rails into the two Frame Ends from Step 1 above. This assembly is easier to maneuver than the entire frame and will allow you to see exactly how the frame lines up and where all of the screws are installed.
3. Line up the Side Bracket from 1.a above, with the screw holes on the (larger) Side Bracket 2" from the edge, and the front most hole at least 6.75" from the front of your desktop.
4. Slide the Center Rails into the open Frame End from the Corner Assembly.

5. Create the final Frame End assembly with the remaining Frame End and Side Bracket.
6. Slide this new assembly onto the Center Rails from Step 4, and position them as you did with the original Frame End Assembly in Step 3. The example below shows a desk top that is 27" deep on either side and 56" wide on either side.

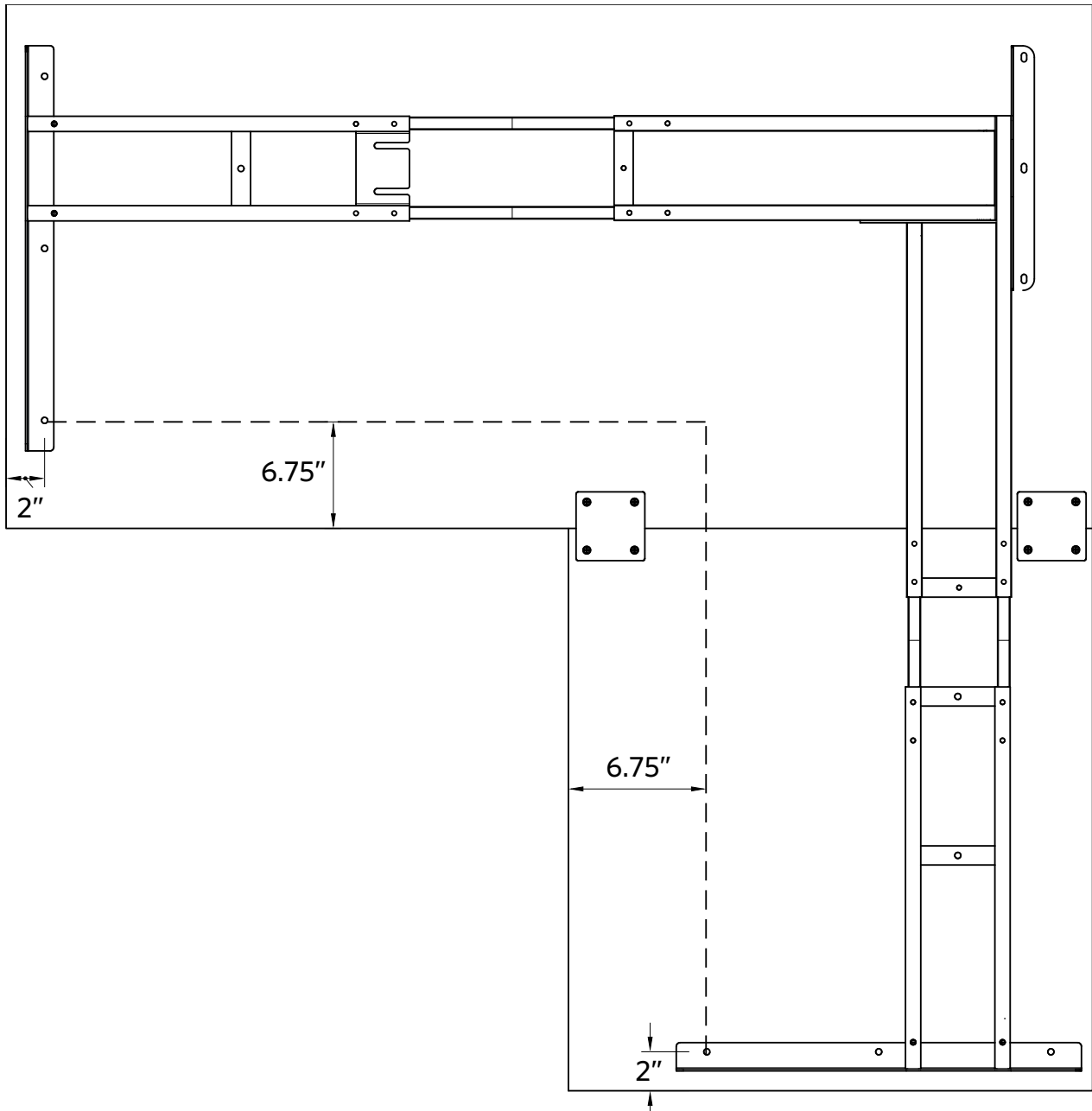

7. Use the tip of a Philips screwdriver to mark the center point of each hole—this is more accurate and permanent than using a marker or pencil.

Return to the standard assembly instructions.

Specs

Height range (without desk top)	23" - 48.5"
Min base width	52.25" - 53.5"
Max base width	75.75" - 78.75"
Travel speed	1.5" per second
Operating noise	<50dB w/o top
Load capacity	1500N
Duty cycle and additional info	10% with max 2 mins on, 18 mins off Soft start/stop Adjustable Leveling Glides 4 Memory Presets

Contact

Fully
Portland, Oregon 97214
888-508-3725
support@fully.com
www.fully.com

Desks, chairs & things
to keep you moving

