

Assembly Instructions

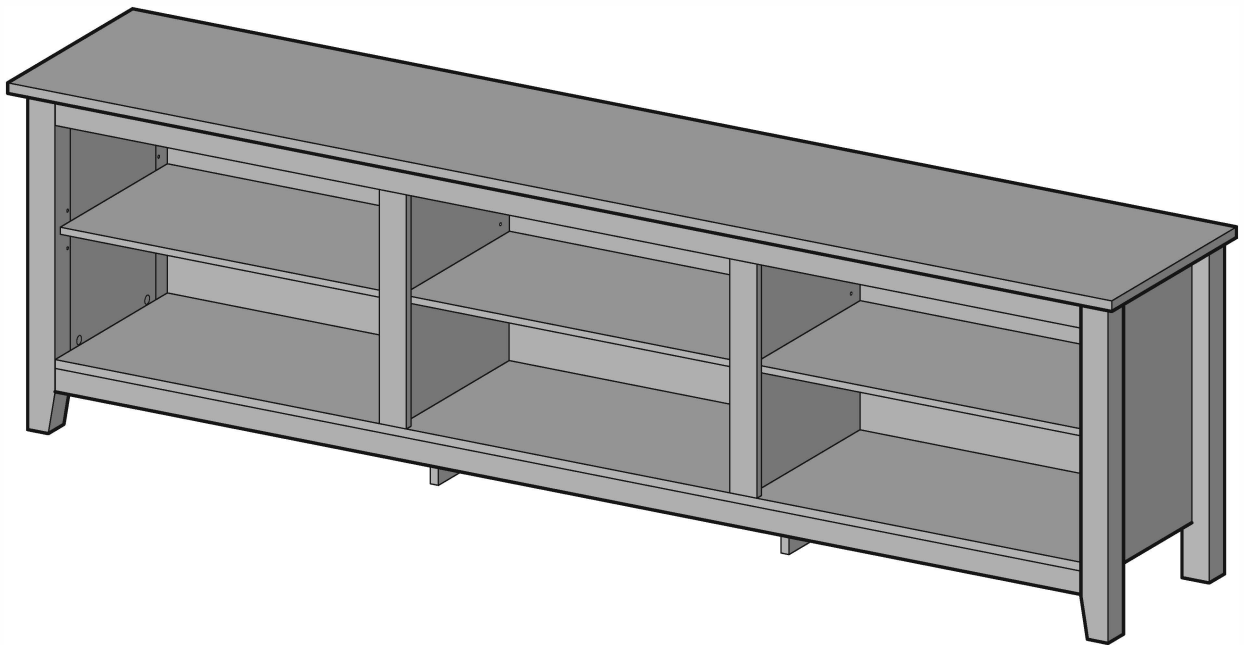

General Assembly Guidelines

- I. Ensure that all parts and hardware are available before beginning assembly.
- II. Follow each step carefully to ensure the proper assembly of this product.
- III. Two people are recommended for ease in the assembly of this product.
- IV. The three main types of hardware used to assemble this product are : wood dowels , screws and bolts.
- V. The provided glue is to secure wood dowels in place . When first inserting dowels , locate the appropriate hole for the dowel , place a small amount of glue in the hole and insert the dowel . Wipe away excess glue immediately.

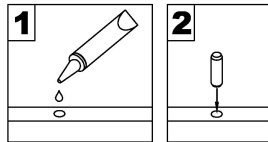

In future assembly steps when dowels are necessary to attach assembly parts together , place a small amount of glue on the end of the dowel before attaching parts together . Wipe away excess glue immediately.

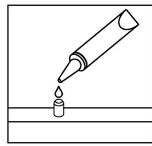

- VI. A Phillips head screwdriver is required for the assembly of this product .

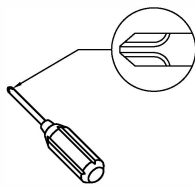



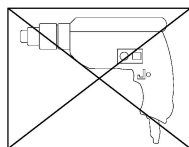



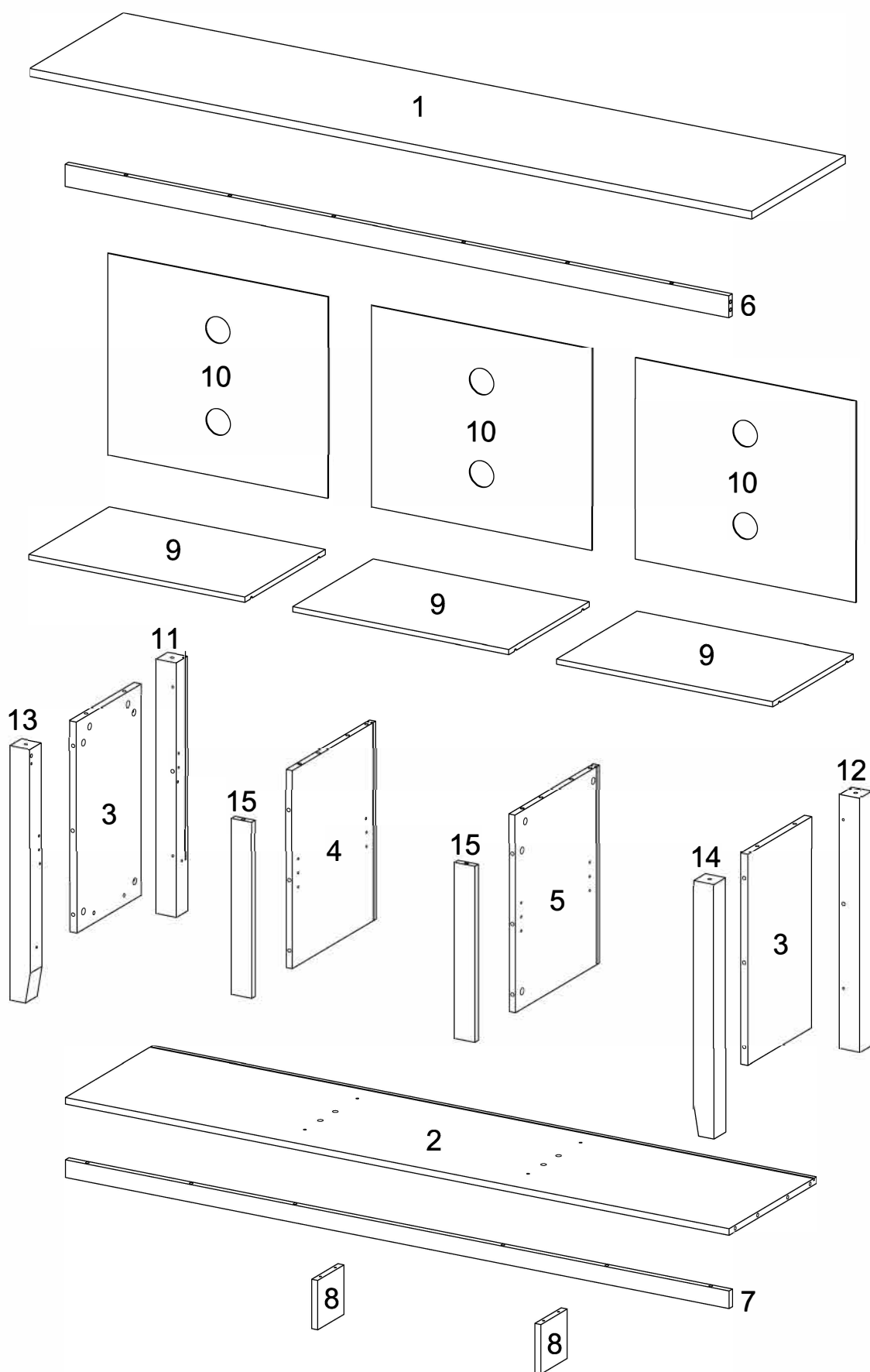

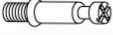

- VII. Power tools should not be used to assemble this product .



Parts List



Hardware List

A		Ø8x30	Wooden dowel	26 pcs
B		Ø6x35	Cam bolt	30 pcs
C		Ø15x12	Cam lock	30 pcs
D		Ø6x50	Bolt	8 pcs
E			Plastic wedge	12 pcs
F			Flat-head screw	12 pcs
G			Shelf support pin	12 pcs
H		M4	Wrench	1 pc
J			Glue tube	1 pc
K		Ø30	Sticker	30 pcs
L		Ø4x45	Screw	4 pcs

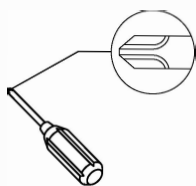

Philips head screwdriver required for assembly
(not included)

*The hardware quantities listed above are required for proper assembly.
Some extra hardware may also have been included.*

Step 1

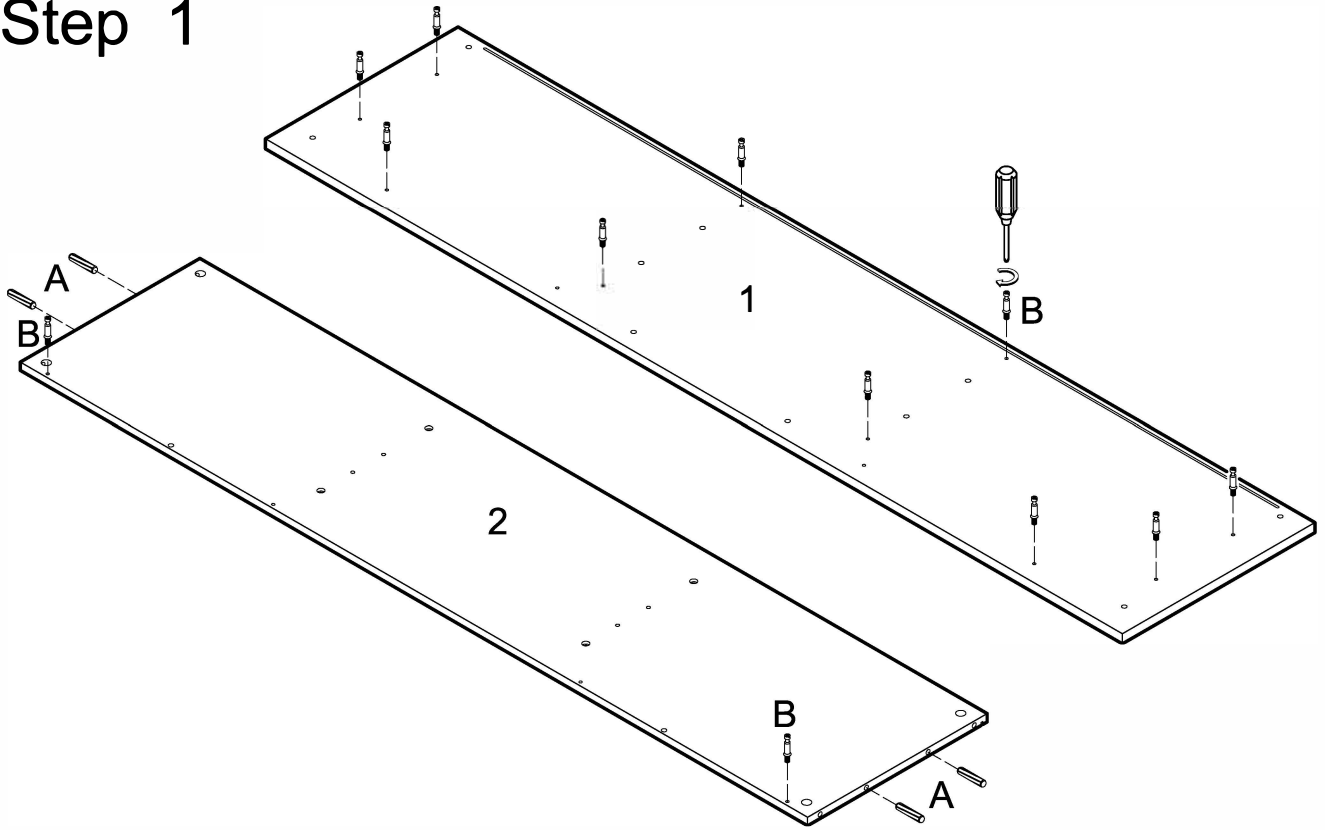

Insert dowels (A) into panel (2). Screw cam bolts (B) into panels (1,2).

Step 2

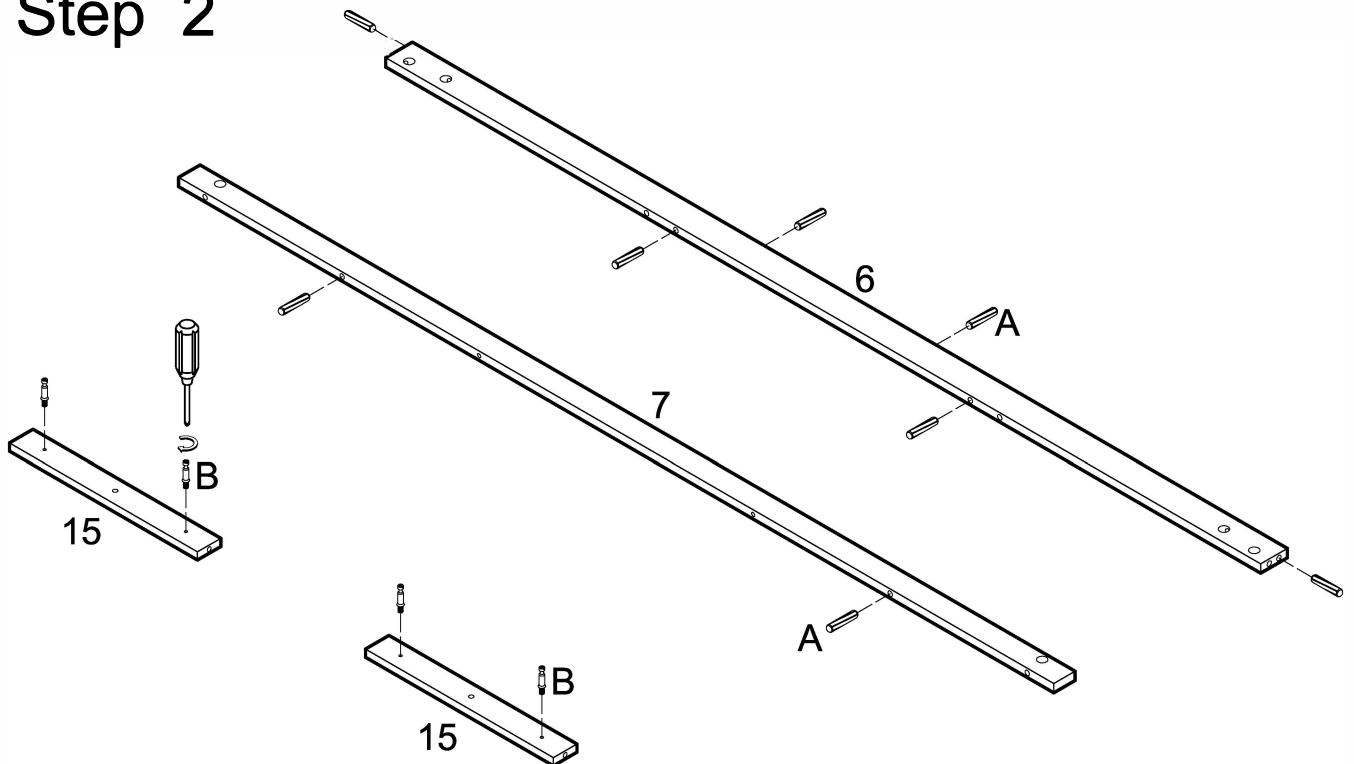

Insert dowels (A) into slats (6,7). Screw cam bolts (B) into slats (15).

Step 3

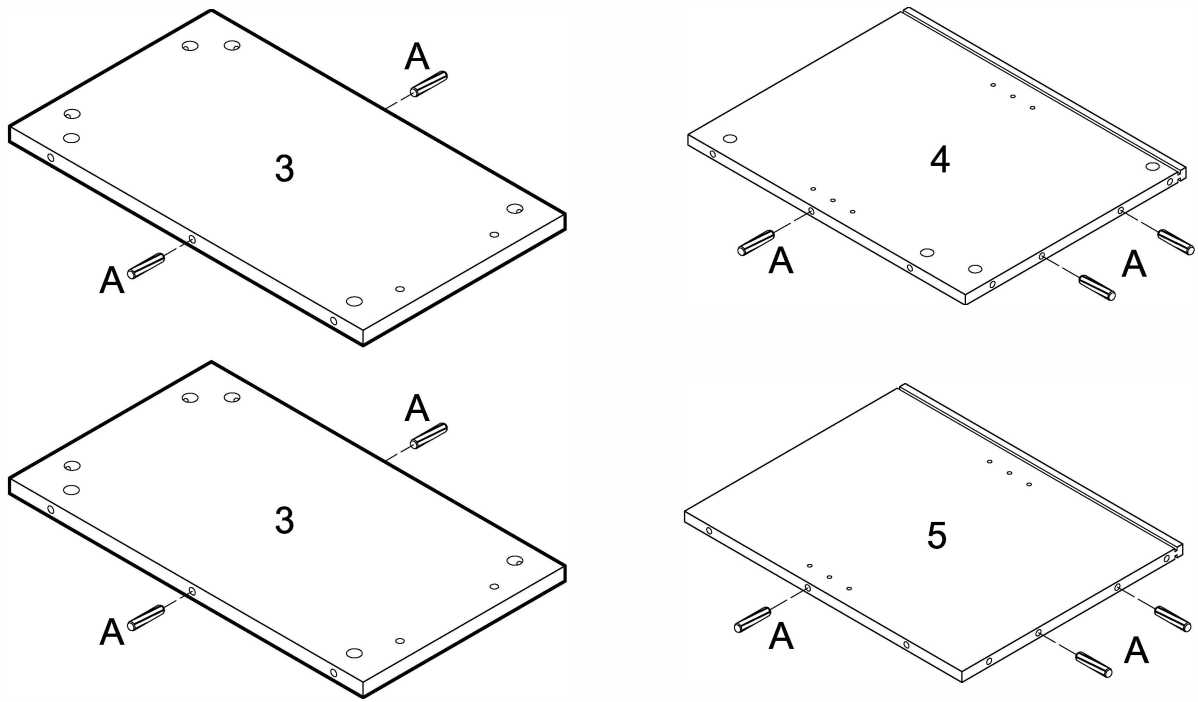

Insert dowels (A) into panels (3,4,5).

Step 4

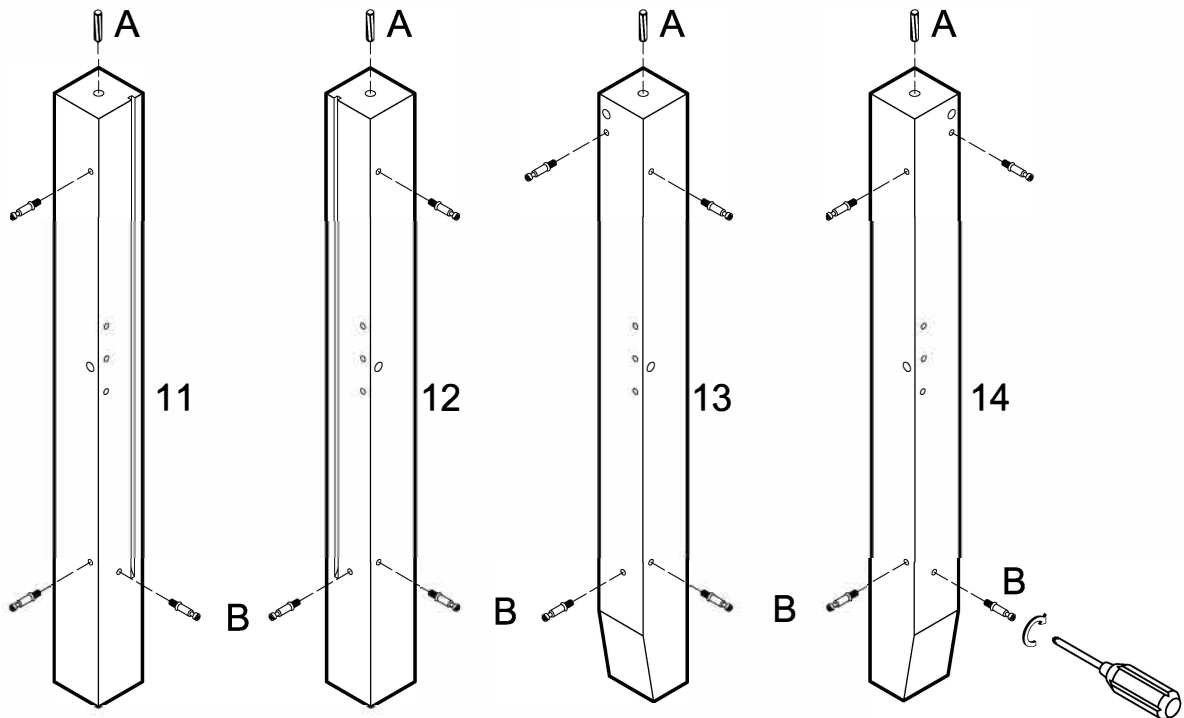

Insert dowels (A) into legs (11,12,13,14) . Screw cam bolts (B) into legs (11,12,13,14).

Step 5

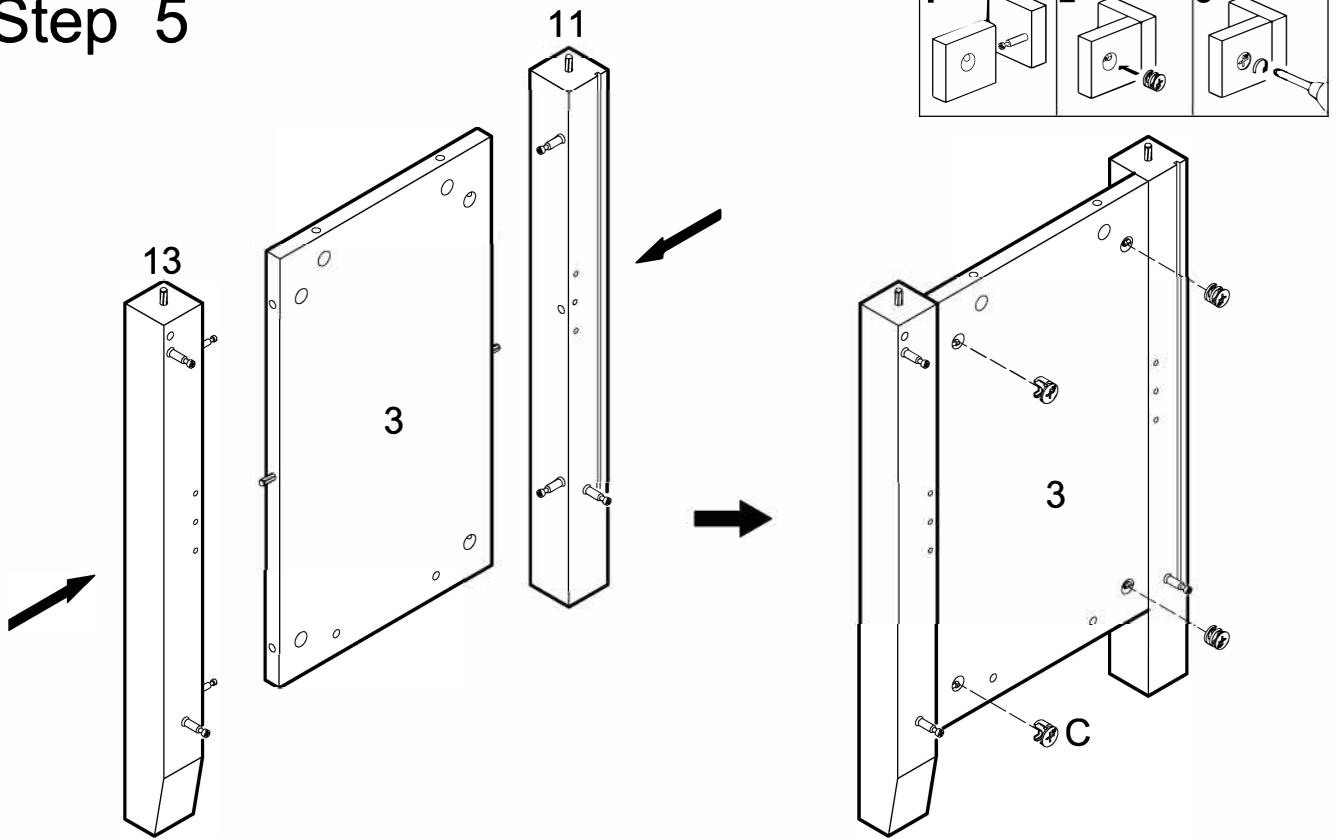

Attach legs (11,13) to panel (3) using cam bolts and dowels as guides. Insert cam locks (C) into panel (3) and tighten with a screwdriver.

Step 6

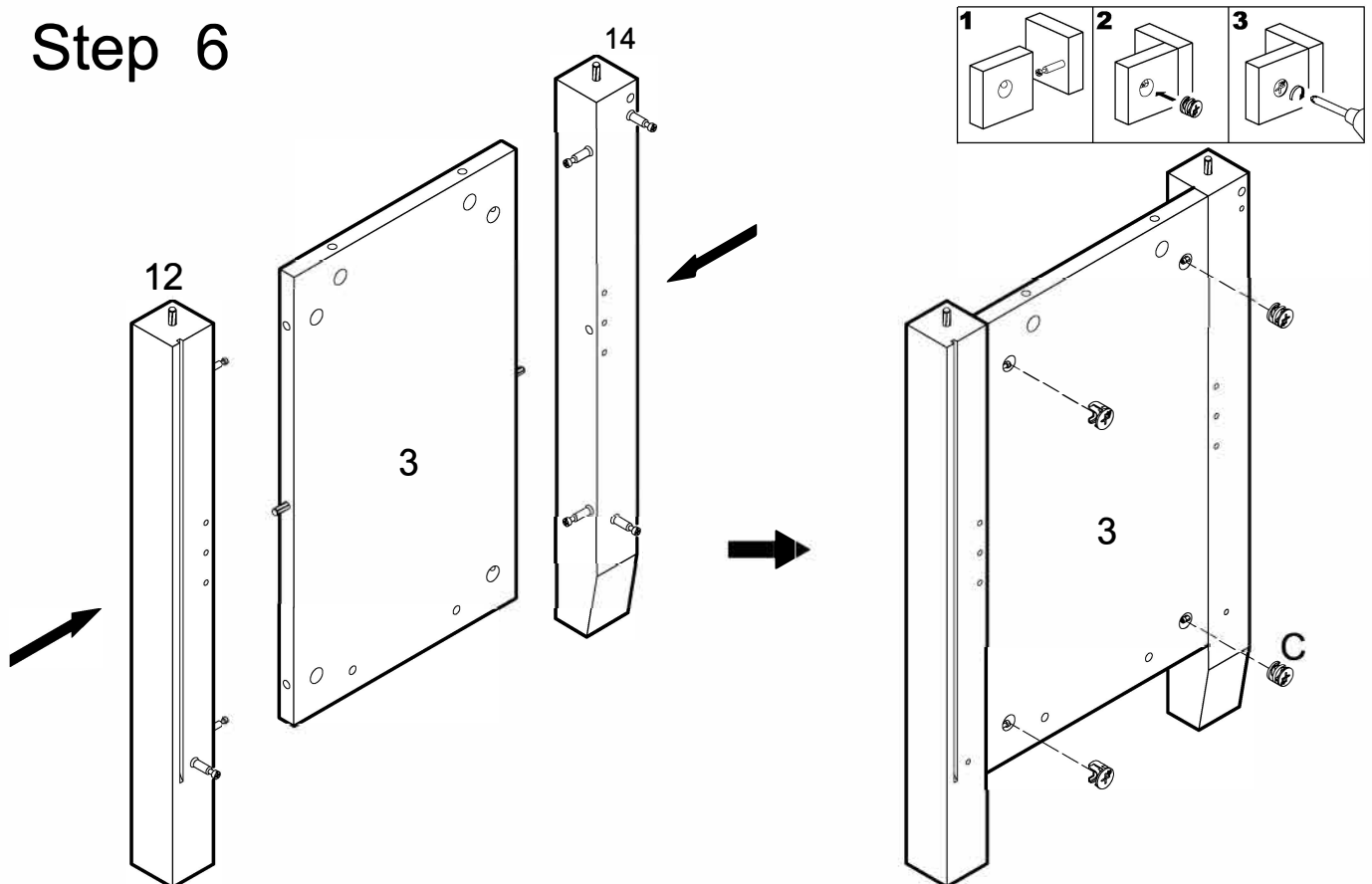

Attach legs (12,14) to second panel (3) using cam bolts and dowels as guides. Insert cam locks (C) into panel (3) and tighten with a screwdriver.

Step 7

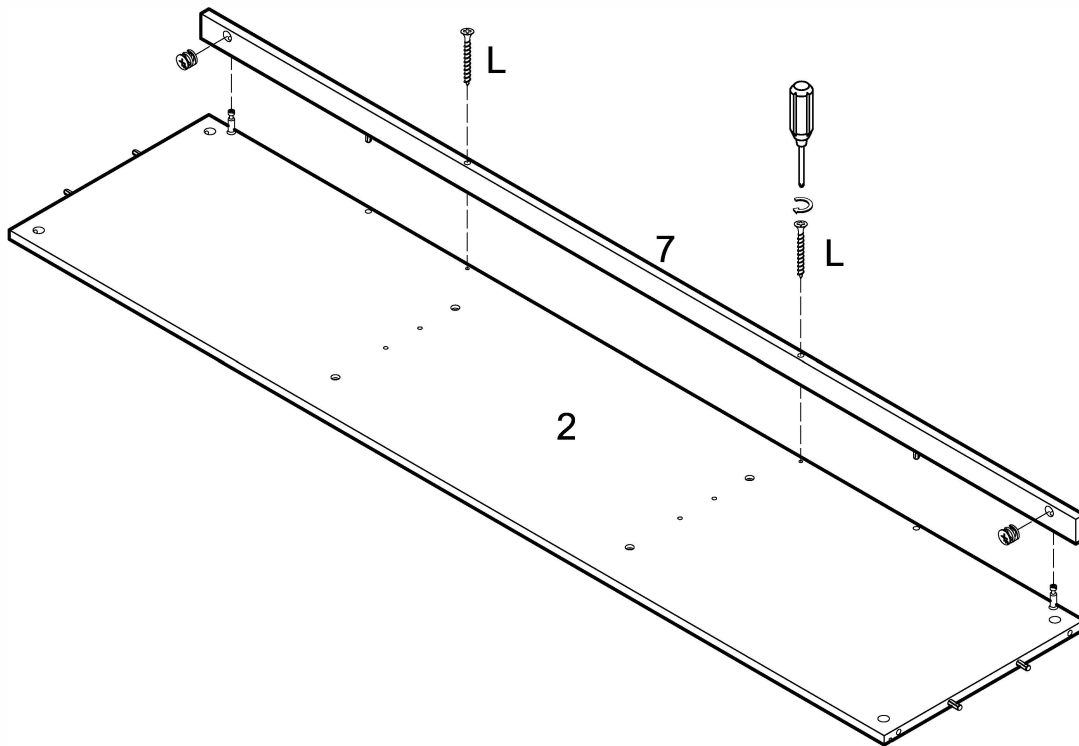

Attach slat (7) to panel (2) using cam bolt as guides. Insert cam lock (C) into slat (7) and tighten with a screwdriver. Secure screw (L) to slat (7) to panel (2).

Step 8

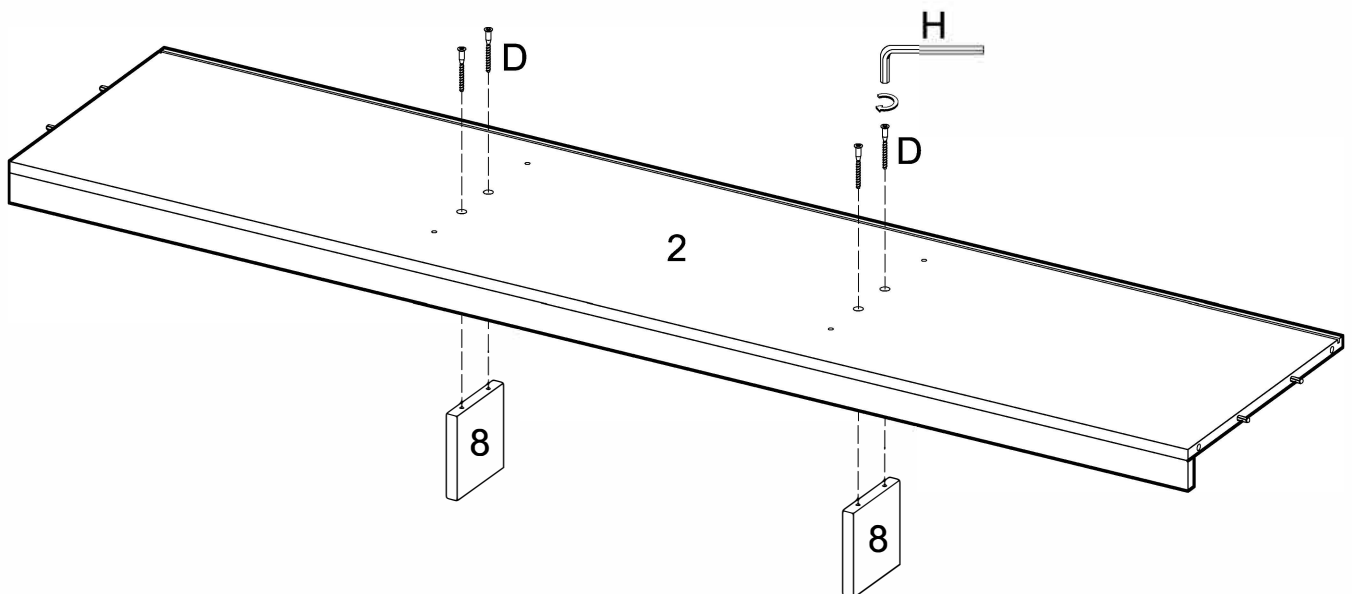

Attach support legs (8) to panel (2) using bolts (D). Tighten bolts (D) with wrench (H).

Step 9

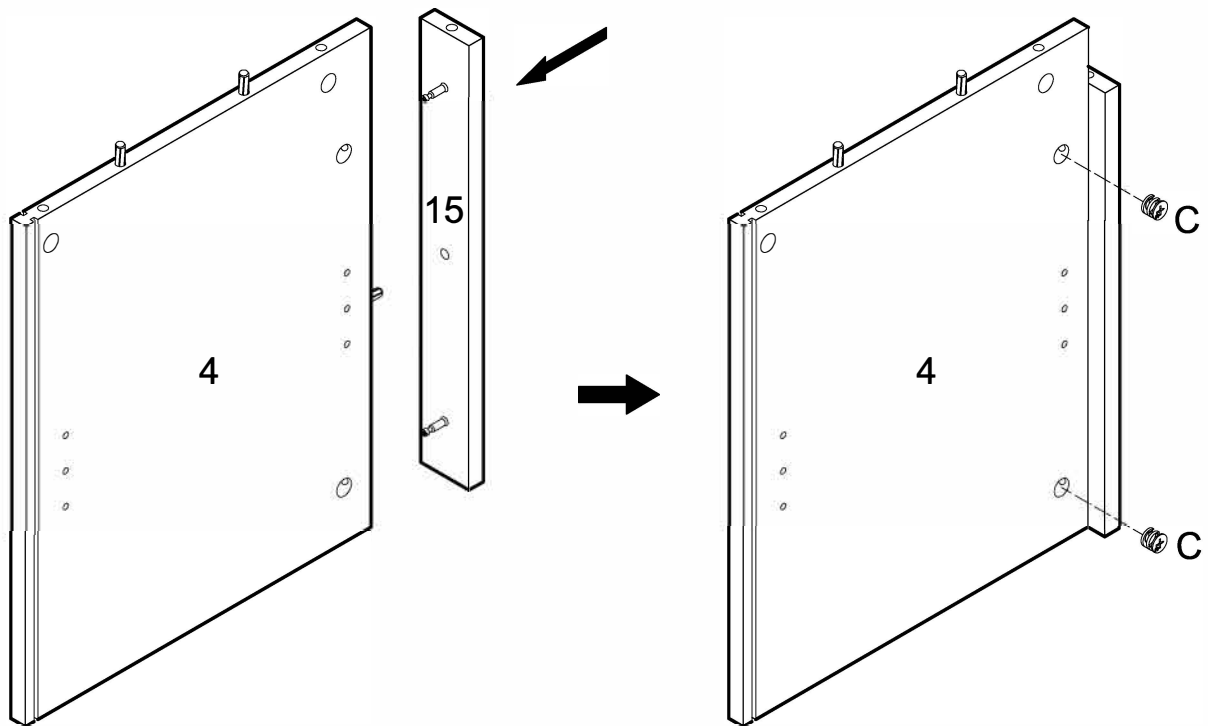

Attach slat (15) to panel (4) using cam bolts and dowel as guides. Insert cam locks (C) into panel (4) and tighten with a screwdriver.

Step 10

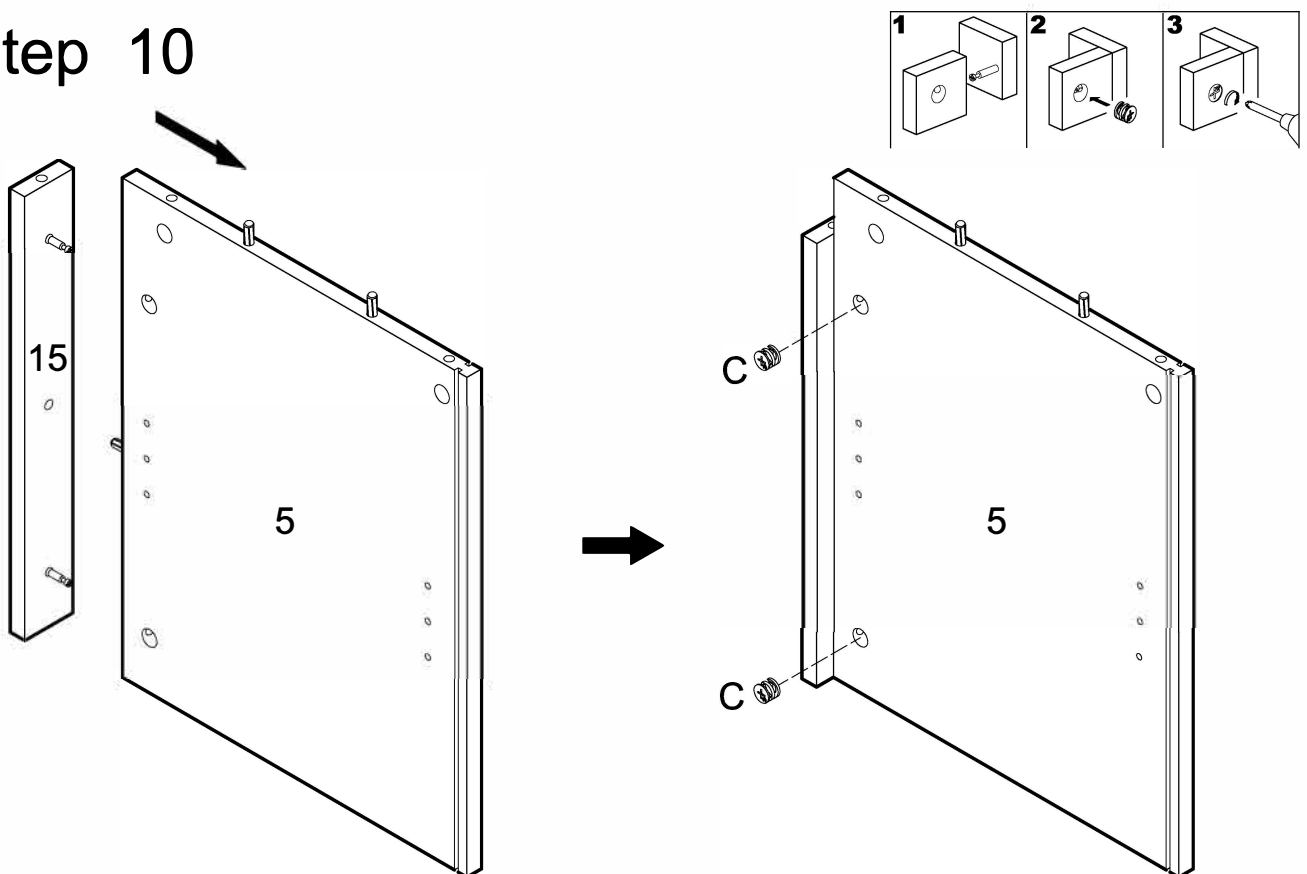

Attach slat (15) to panel (5) using cam bolts and dowel as guides. Insert cam locks (C) into panel (5) and tighten with a screwdriver.

Step 11

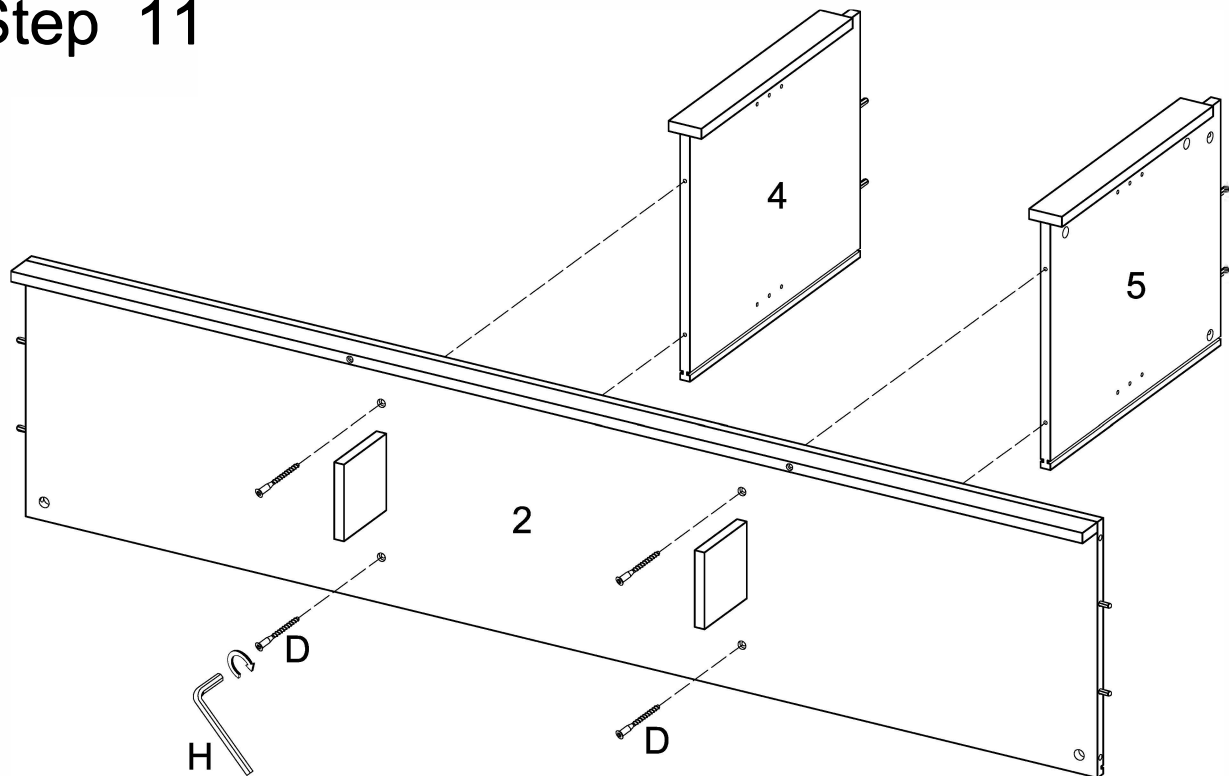

Attach panel (4,5) to panel (2) using bolts (D). Tighten bolts (D) with wrench (H).

Step 12

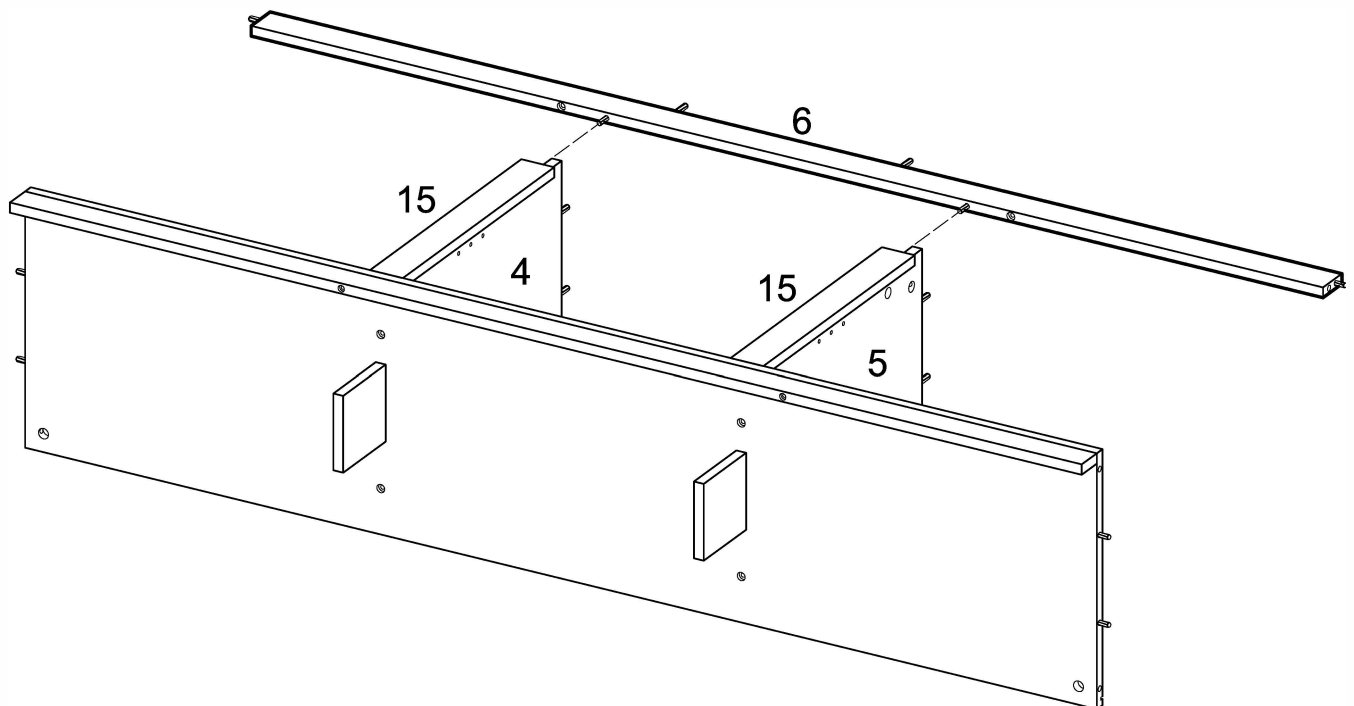

Attach slat (6) to slats (15) using dowel as guide.

Step 13

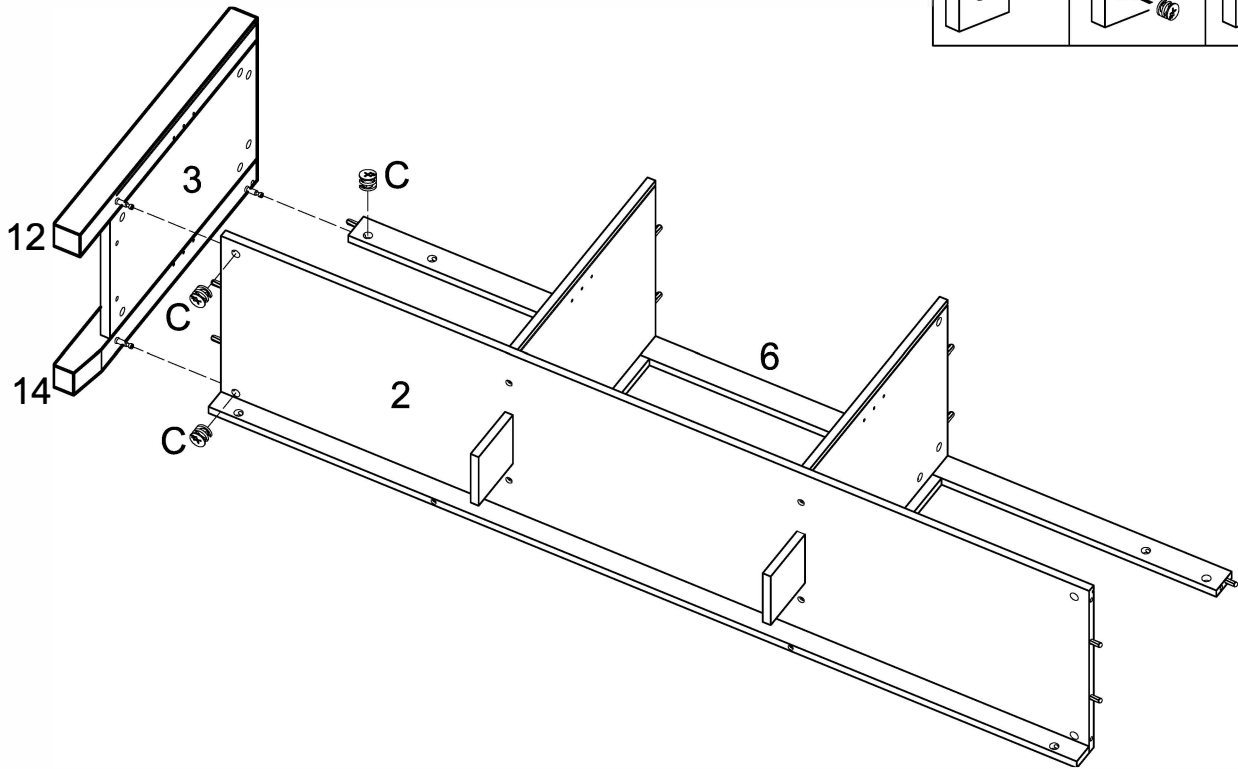
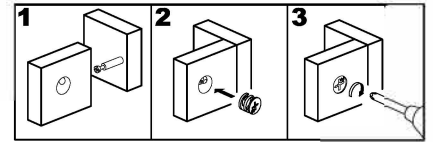

Attach panel (3) with legs (12,14) to the assembly from the previous step using cam bolts and dowels as guides. Insert cam locks (C) into panel (2) and slat (6) and tighten with a screwdriver.

Step 14

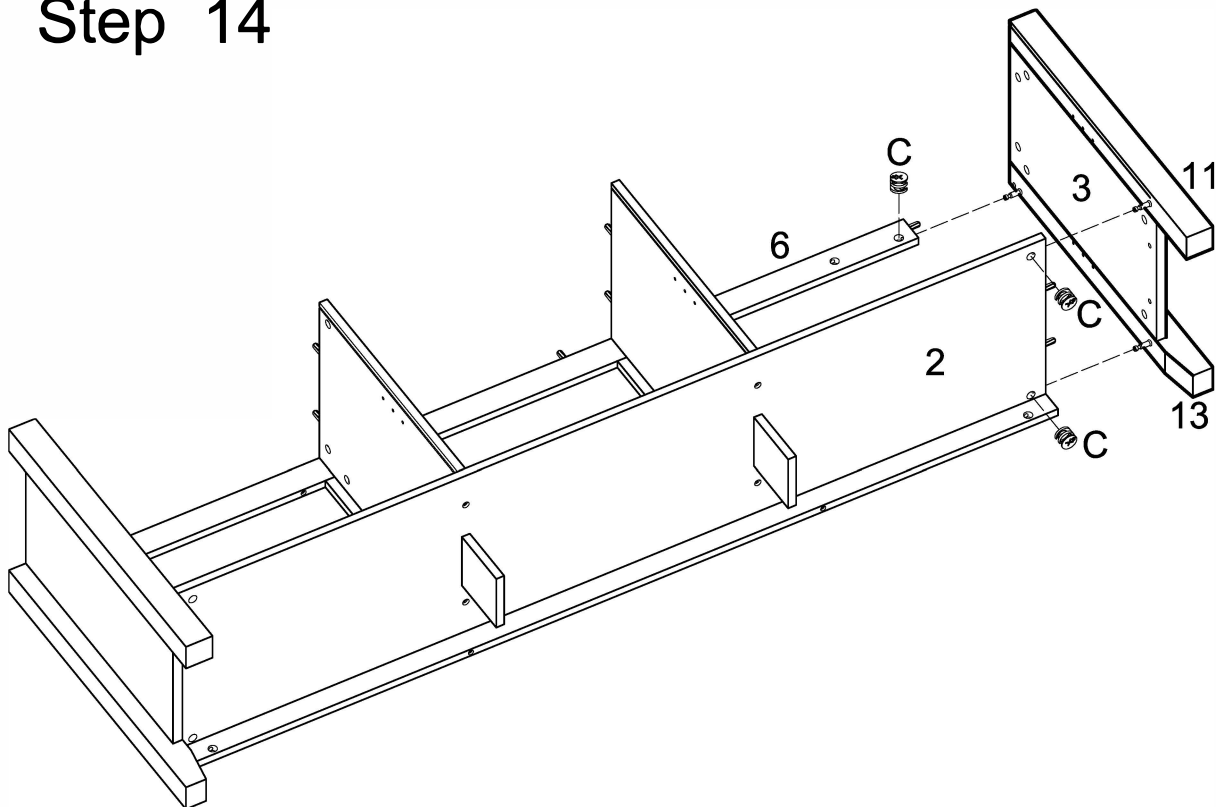
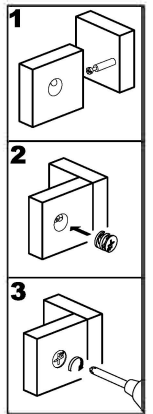

Attach second panel (3) with legs (11,13) to the assembly from the previous step using cam bolts and dowels as guides. Insert cam locks (C) into panel (2) and slat (6) and tighten with a screwdriver.

Step 15

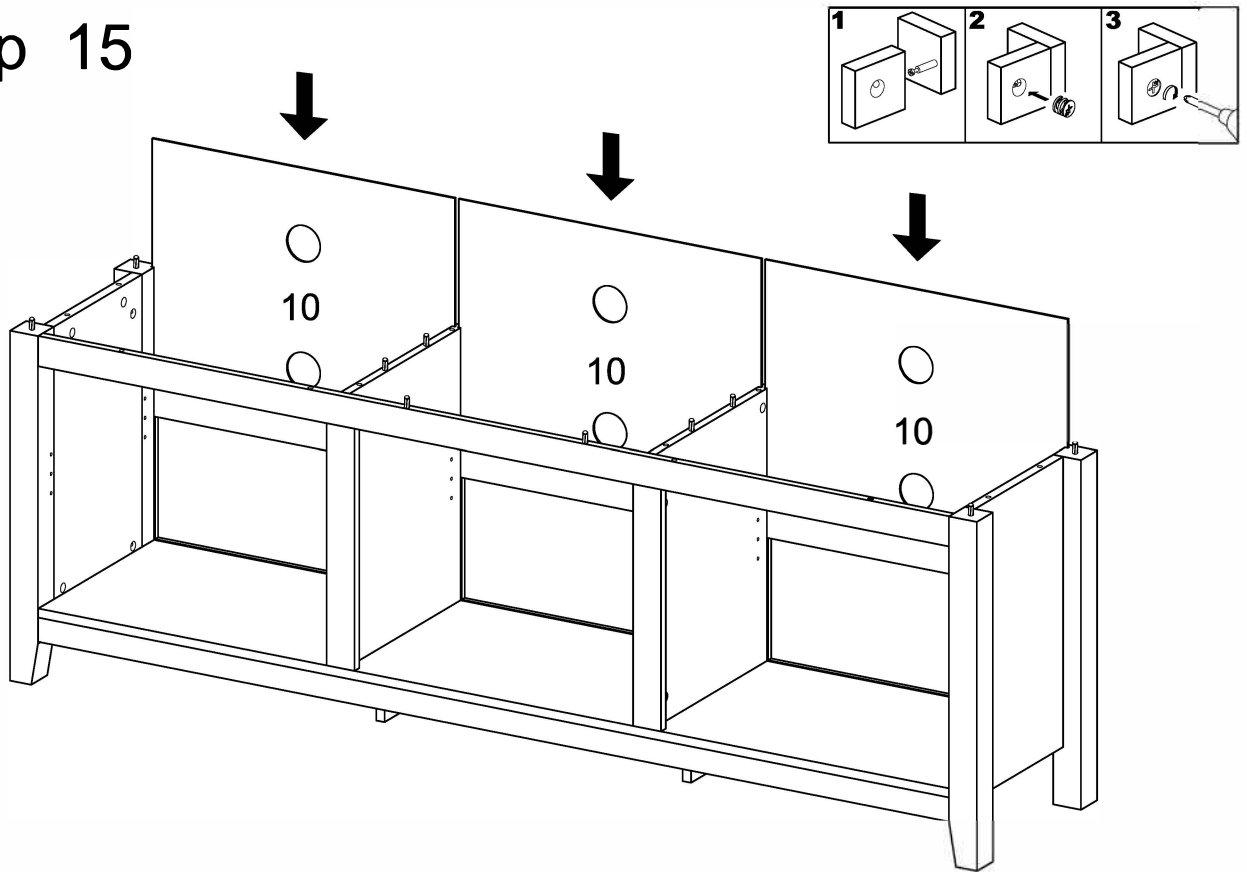

Carefully slide panels (10) into place along the back of the assembly.

Step 16

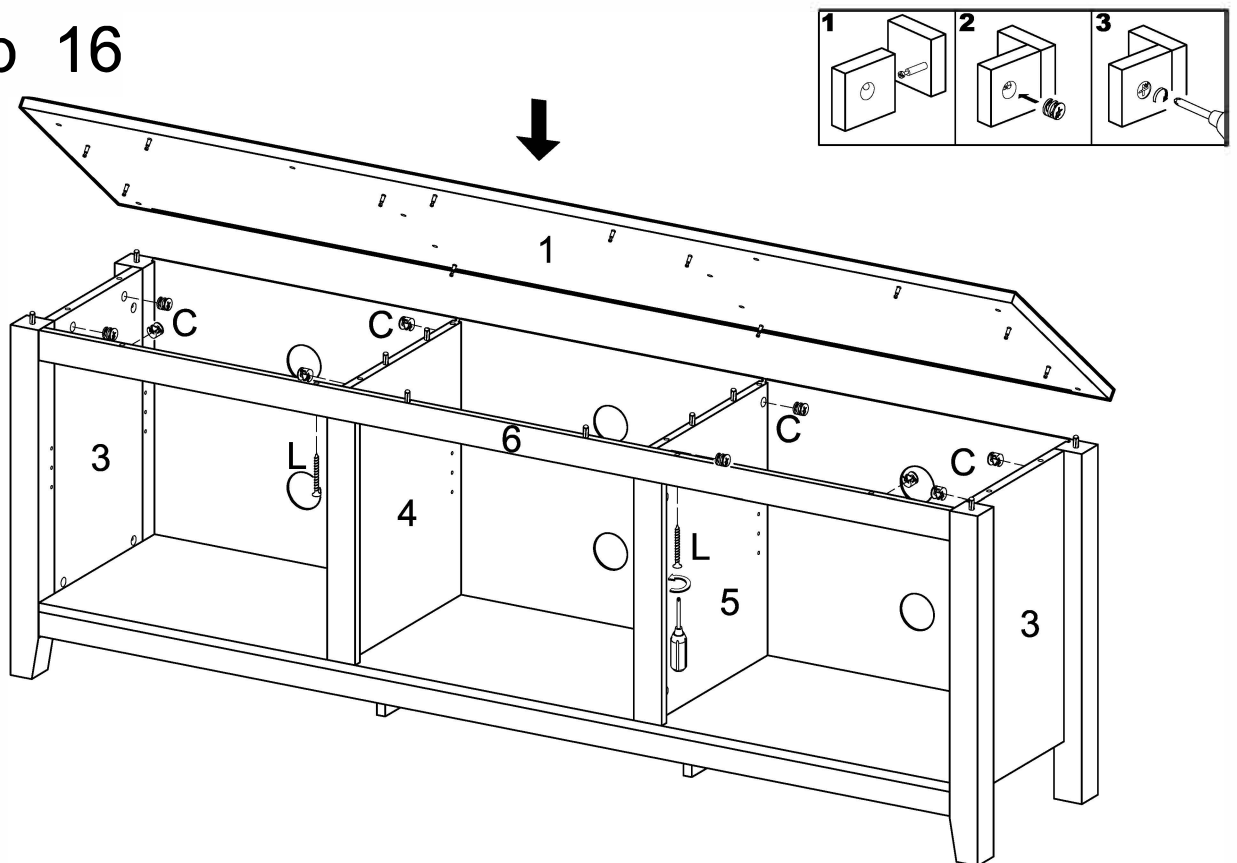

Carefully attach panel (1) to the assembly using cam bolts and dowels as guides. Insert cam locks (C) into the assembly as shown above and tighten with a screwdriver. Secure screw (L) to slat (6) to panel (1).

Step 17

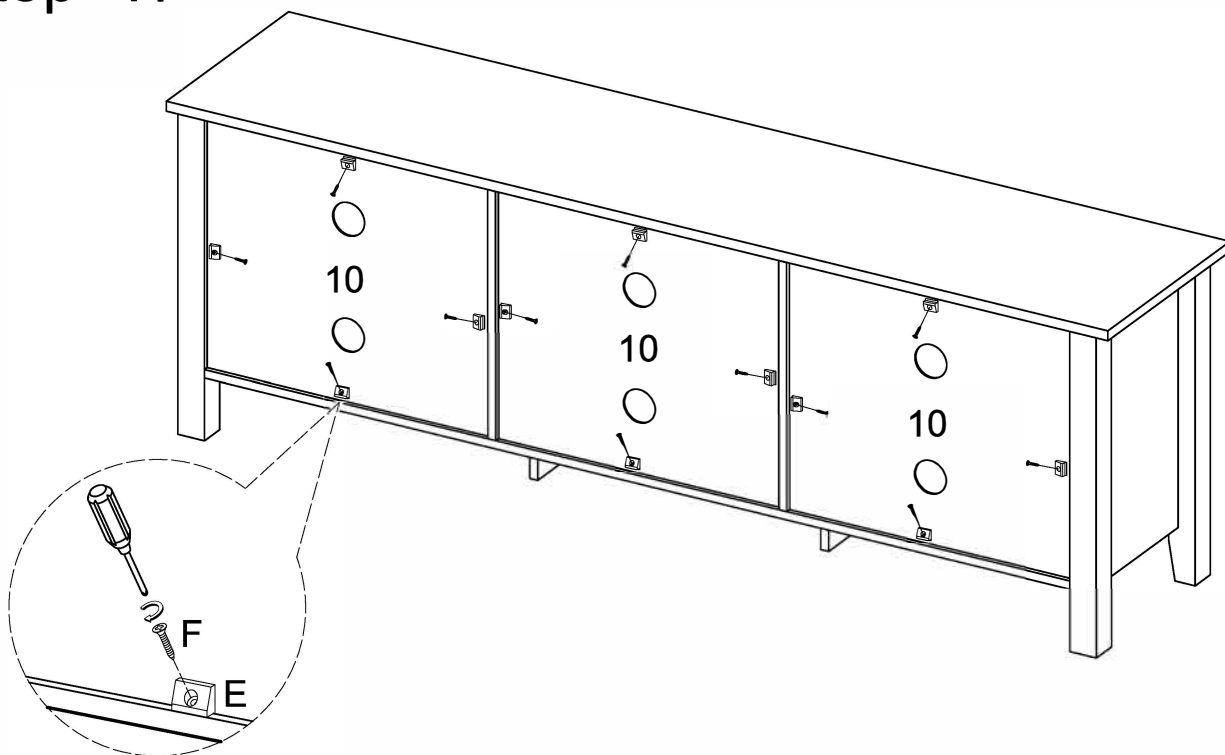

Secure panels (10) with plastic wedges (E) and screws (F).

Step 18

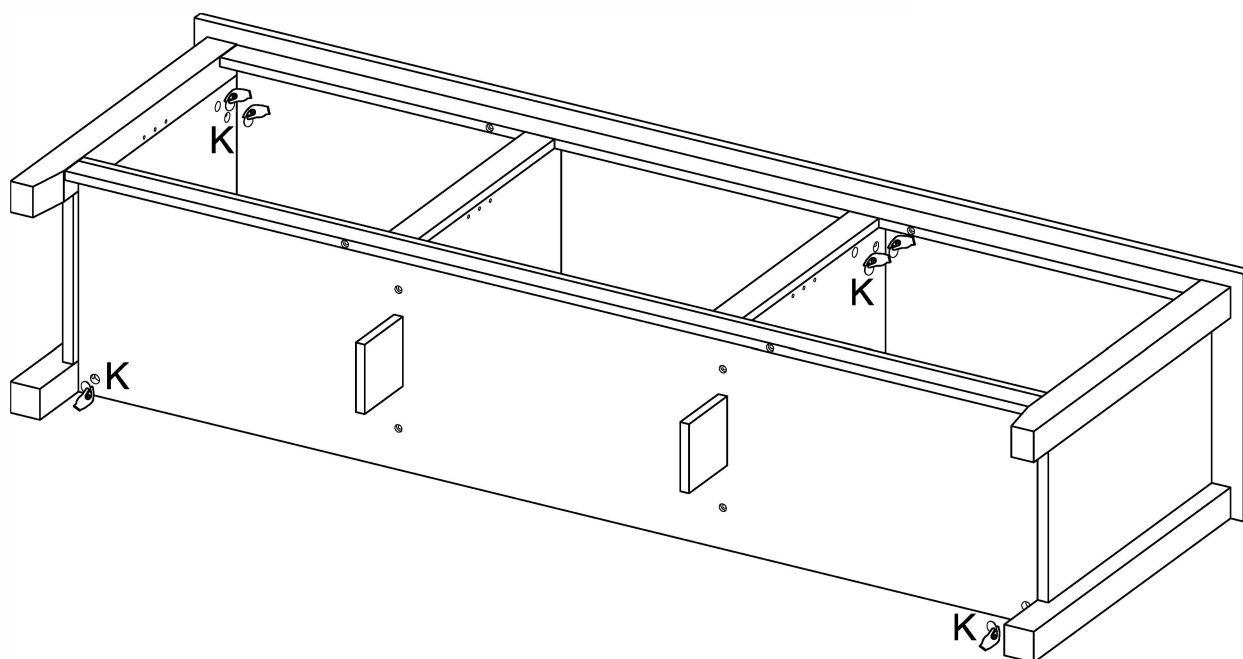
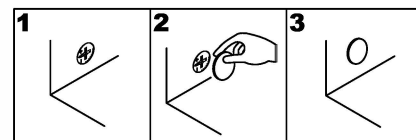

Cover all visible cam locks with stickers (K) as desired.

Step 19

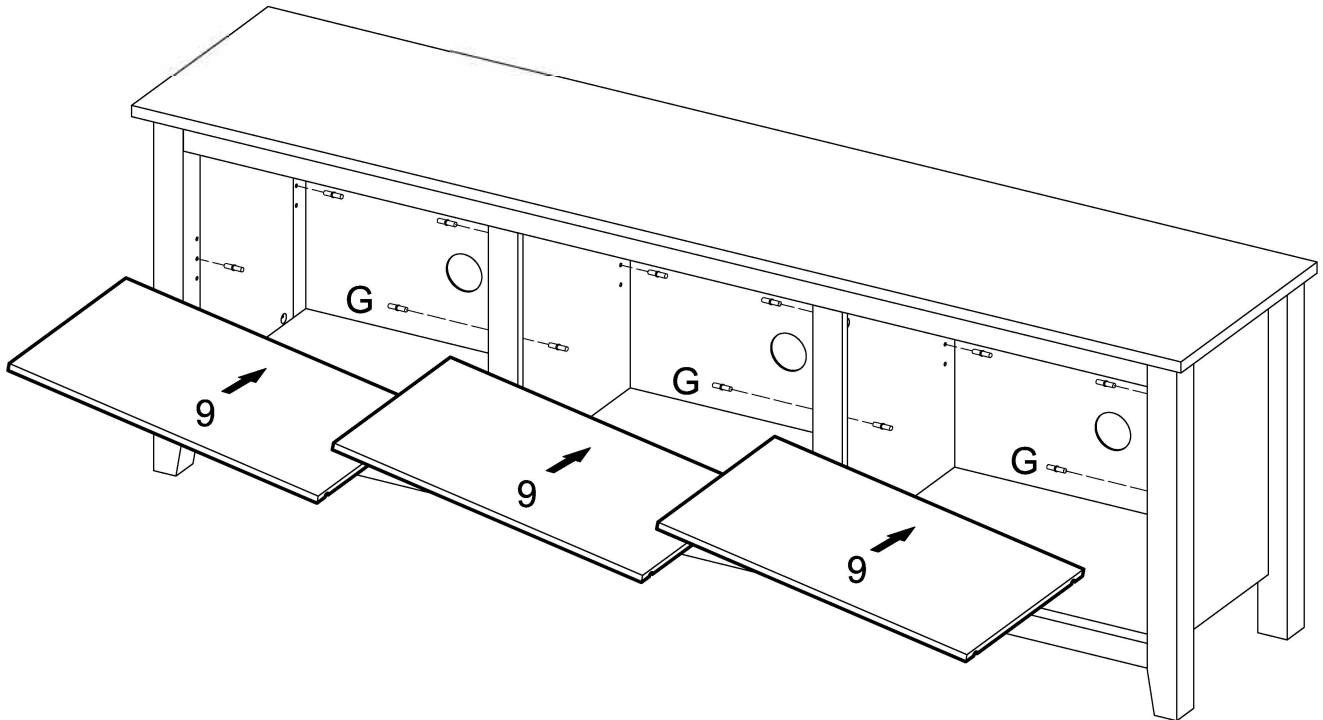

Insert shelf support pins (G) into the assembly at desired shelf heights. Carefully place shelves (9) on shelf support pins (G).

Step 20

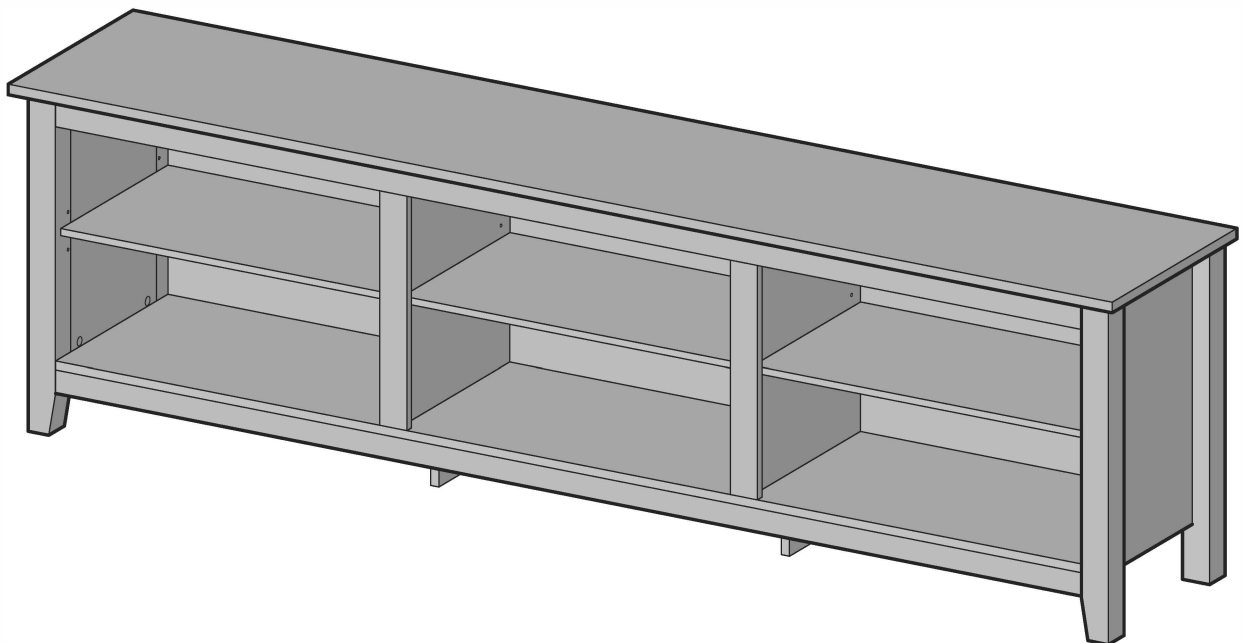

Final Assembly