

Scan the QR
code to watch the
assembly video

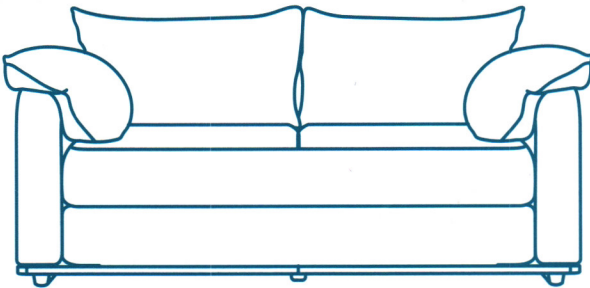

CUSHY
SOFA BED



What's in the box*:

*Not to scale



x6
Long Leg
104-9250



x3 / x1
Queen Double / Single
Short Leg
104-9251

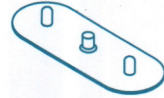

x1
Baseboard Connector
104-9239

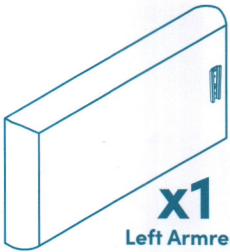

x1
Left Armrest

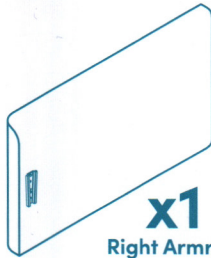

x1
Right Armrest

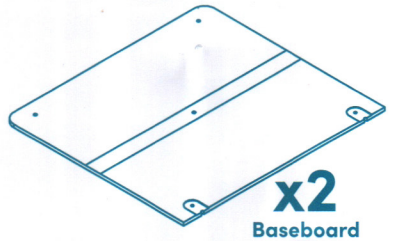

x2
Baseboard

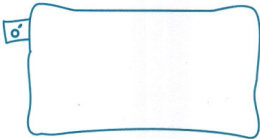

x2/x1
Queen Double/Single
Backrest Cushion

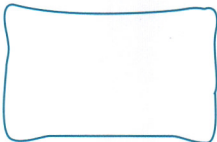

x2
Armrest Cushion

x1
Backrest

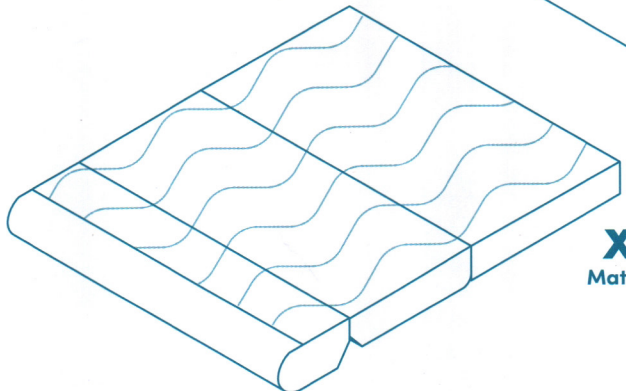
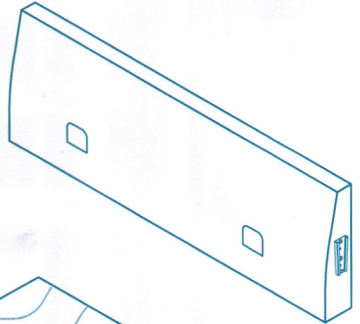

x1
Mattress



NOTE - Open the seat cushion box first.
Due to compression, max comfort reached after
3-5 days.

- 1.** Connect the two arms to the backrest using the wedge brackets.

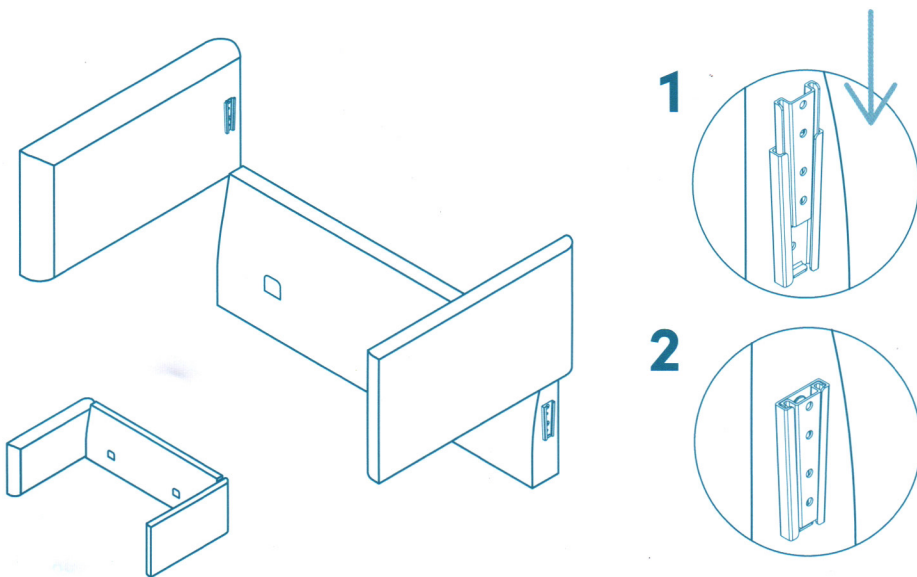

- 2.** Ensure sofa bed is positioned away from walls and carefully rotate the sofa bed on its back.

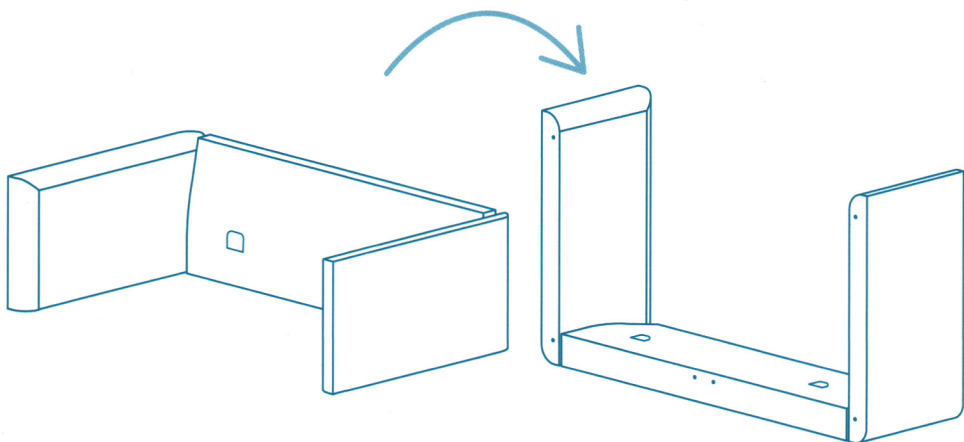

- 3.** Screw baseboard with the velcro facing in, onto frame using the longer length thread legs in the order shown.



x3

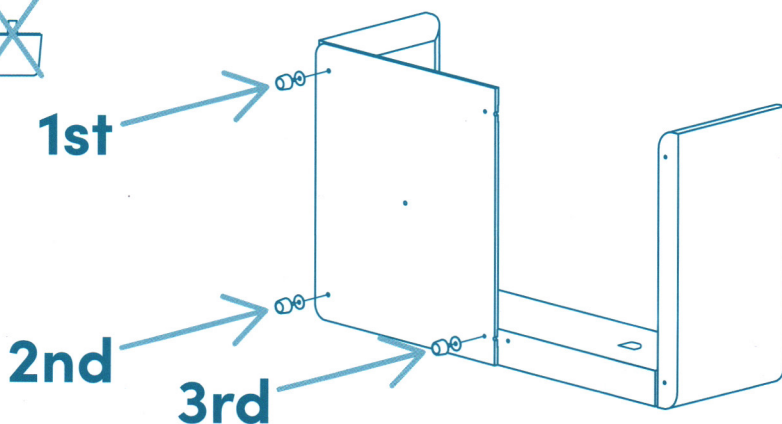

NOTE - Use coloured stickers on armrest and backrest as alignment guide.

- 4.** Screw second baseboard with the velcro facing in, onto frame using the longer length thread legs in the order shown.



x3

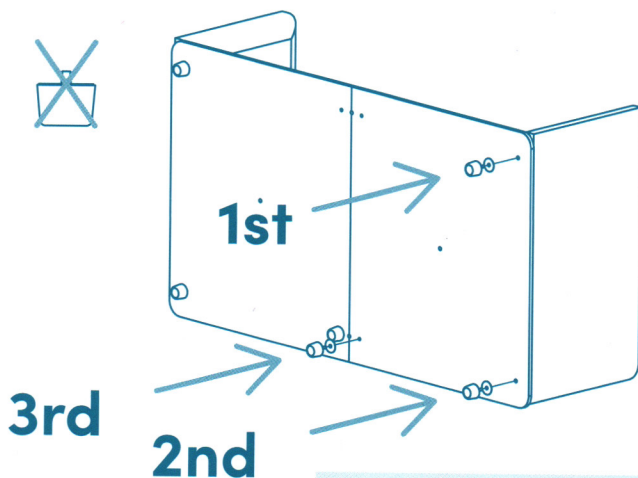

NOTE - Use coloured stickers on armrest and backrest as alignment guide.

5. Screw in connector plate using the shorter length thread leg.



x1



x1

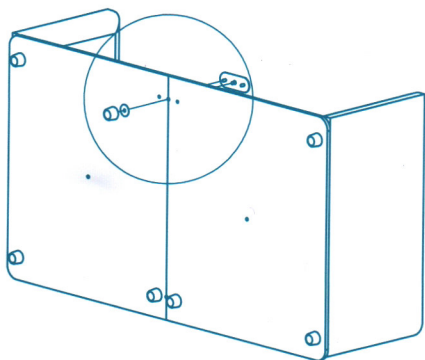

1

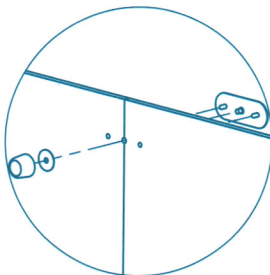

2

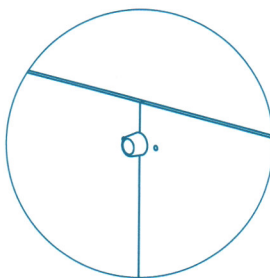

6. Screw shorter thread legs into baseboard.

HEADS UP!

Your single Cushy Sofa Bed does not require middle legs!



x2

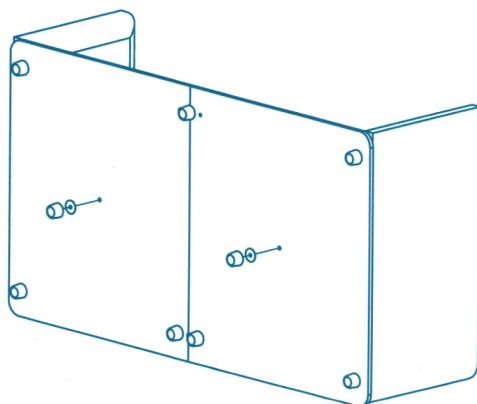

7. Carefully lower the sofa bed on its legs.

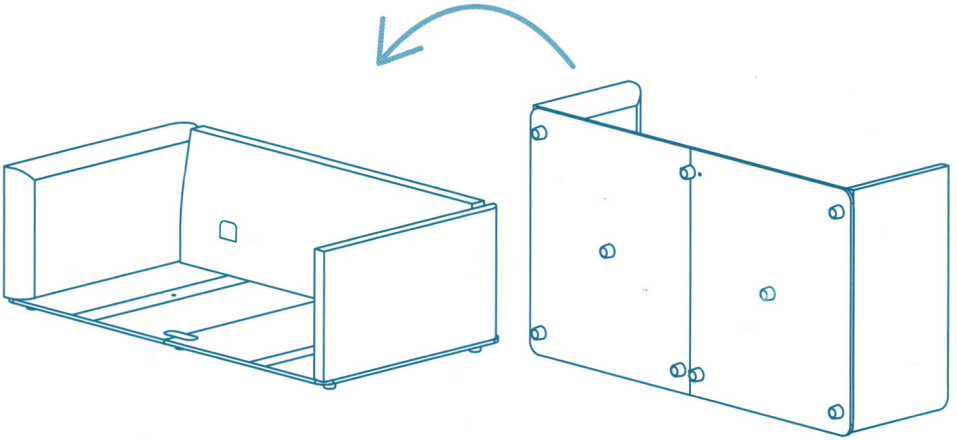

8. Attach mattress to frame using velcro.

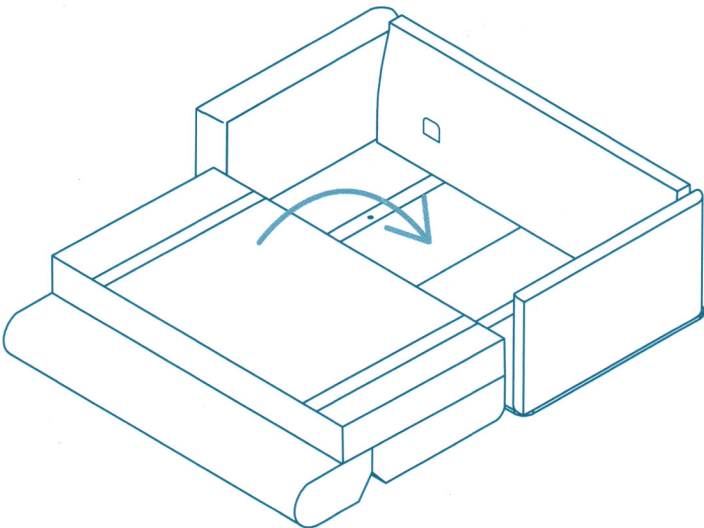

- 9.** Fold up the mattress to convert the sofa bed into its seating position.

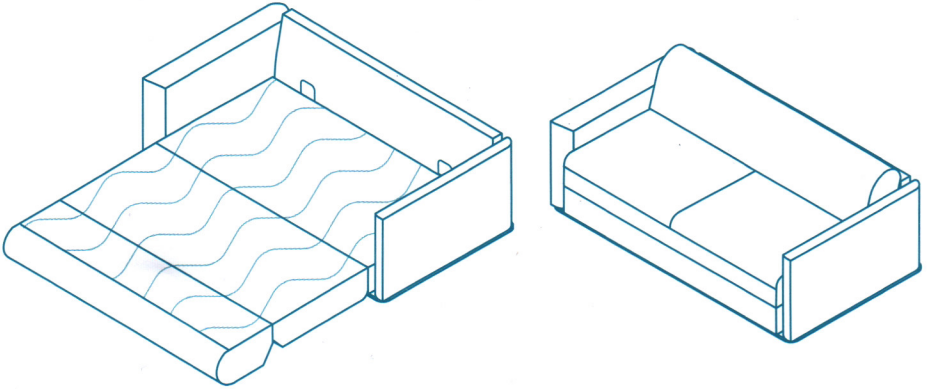

-
- 10.** Add your backrest and armrest cushions.



Ensure backrest
cushion tag is on
outside