

NordicTrack® VU19

nordictrack.com

Model No. NTEX76918.0

Serial No. _____

Write the serial number in the space above for reference.

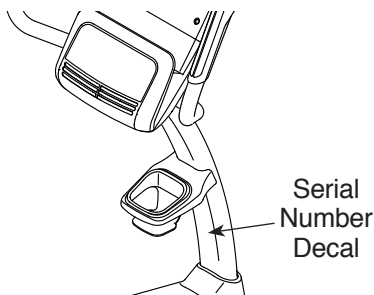

ACTIVATE YOUR WARRANTY

To register your product and activate your warranty today, go to my.nordictrack.com.

CUSTOMER CARE

For service at any time, go to nordictrackservice.com.

Or call 1-800-TO-BE-FIT
(1-800-862-3348)
Mon.–Fri. 6 a.m.–6 p.m. MT
Sat. 8 a.m.–12 p.m. MT

Please do not contact the store.

⚠ CAUTION

Read all precautions and instructions in this manual before using this equipment. Keep this manual for future reference.

USER'S MANUAL

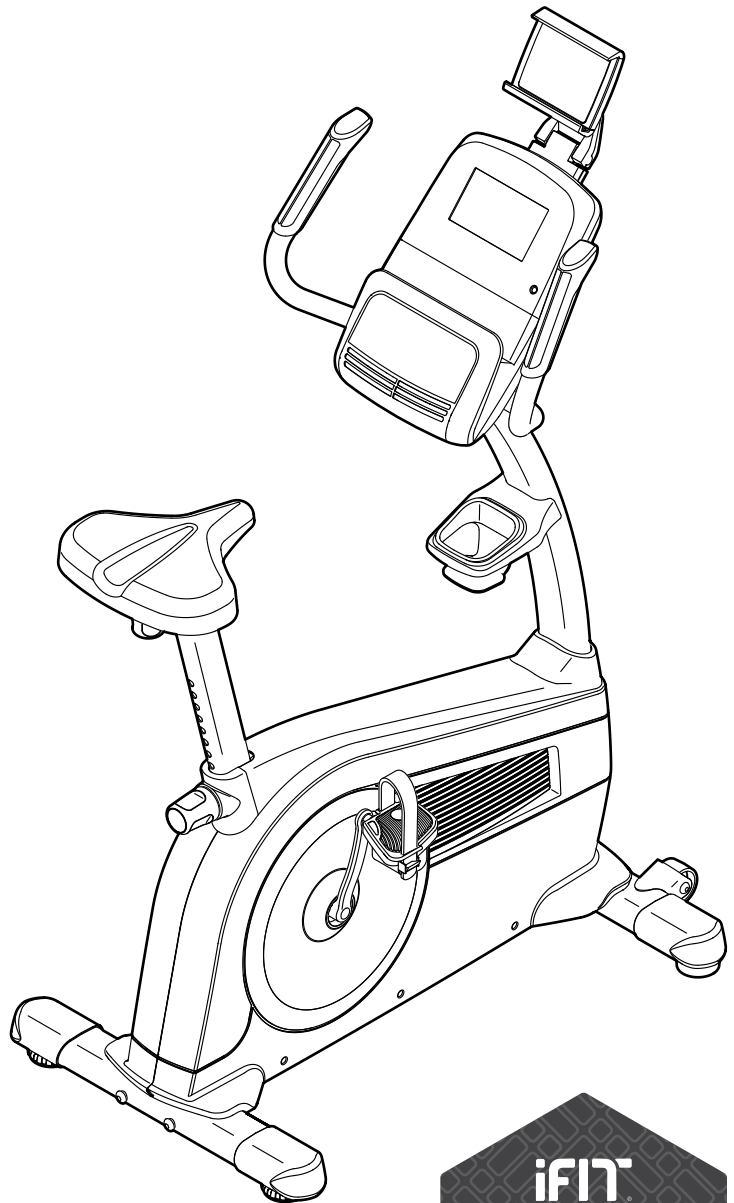
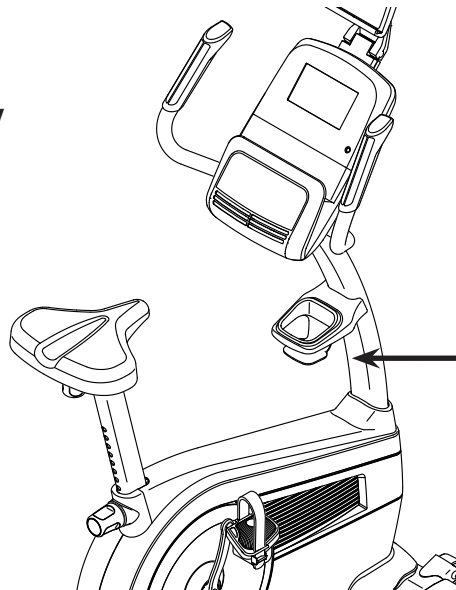

TABLE OF CONTENTS

WARNING DECAL PLACEMENT	2
IMPORTANT PRECAUTIONS	3
BEFORE YOU BEGIN	5
PART IDENTIFICATION CHART	6
ASSEMBLY	7
THE CHEST HEART RATE MONITOR	15
HOW TO USE THE EXERCISE BIKE	16
FCC INFORMATION	27
MAINTENANCE AND TROUBLESHOOTING	28
EXERCISE GUIDELINES	29
PART LIST	30
EXPLODED DRAWING	31
ORDERING REPLACEMENT PARTS	Back Cover
LIMITED WARRANTY	Back Cover

WARNING DECAL PLACEMENT

This drawing shows the location(s) of the warning decal(s). **If a decal is missing or illegible, see the front cover of this manual and request a free replacement decal. Apply the decal in the location shown.** Note: The decal(s) may not be shown at actual size.



WARNING

- Misuse of this machine may result in serious injury.
- Read user's manual prior to use and follow all warnings and instructions.
- Do not allow children on or around machine.
- User weight must not exceed 325 lbs. / 147 kgs.
- This product should always be used on a level surface.
- This product is not intended for therapeutic use.
- Replace label if damaged, illegible, or removed.



NORDICTRACK and IFIT are registered trademarks of ICON Health & Fitness, Inc. The BLUETOOTH® word mark and logos are registered trademarks of Bluetooth SIG, Inc. and are used under license. Google Maps is a trademark of Google Inc. Wi-Fi is a registered trademark of Wi-Fi Alliance. WPA and WPA2 are trademarks of Wi-Fi Alliance.

IMPORTANT PRECAUTIONS

⚠ WARNING: To reduce the risk of serious injury, read all important precautions and instructions in this manual and all warnings on your exercise bike before using your exercise bike. ICON assumes no responsibility for personal injury or property damage sustained by or through the use of this product.

1. It is the responsibility of the owner to ensure that all users of the exercise bike are adequately informed of all precautions.
2. Before beginning any exercise program, consult your physician. This is especially important for persons over age 35 or persons with pre-existing health problems.
3. The exercise bike is not intended for use by persons with reduced physical, sensory, or mental capabilities or lack of experience and knowledge, unless they are given supervision or instruction about use of the exercise bike by someone responsible for their safety.
4. Use the exercise bike only as described in this manual.
5. The exercise bike is intended for home use only. Do not use the exercise bike in a commercial, rental, or institutional setting.
6. Keep the exercise bike indoors, away from moisture and dust. Do not put the exercise bike in a garage or covered patio, or near water.
7. Place the exercise bike on a level surface with at least 2 ft. (0.6 m) of clearance around the exercise bike. To protect the floor or carpet from damage, place a mat under the exercise bike.
8. Inspect and properly tighten all parts each time the exercise bike is used. Replace any worn parts immediately.
9. Keep children under age 13 and pets away from the exercise bike at all times.
10. Wear appropriate clothes while exercising; do not wear loose clothes that could become caught on the exercise bike. Always wear athletic shoes for foot protection.
11. The exercise bike should not be used by persons weighing more than 325 lbs. (147 kg).
12. Be careful when mounting and dismounting the exercise bike.
13. The heart rate monitor is not a medical device. Various factors, including the user's movement, may affect the accuracy of heart rate readings. The heart rate monitor is intended only as an exercise aid in determining heart rate trends in general.
14. Always keep your back straight while using the exercise bike; do not arch your back.
15. Over exercising may result in serious injury or death. If you feel faint, if you become short of breath, or if you experience pain while exercising, stop immediately and cool down.

PROTECT

YOUR FITNESS EQUIPMENT
WITH AN EXTENDED SERVICE PLAN

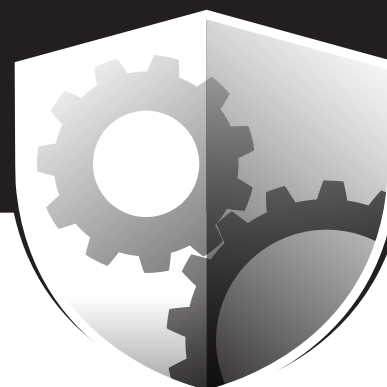

Your new fitness equipment is not an ordinary purchase; it is an investment in your health and well being for years to come.

As the leading provider of manufacturer's extended service plans, ICON strives to protect your equipment and your future.

Please review the following service plans and find one that best fits your needs.

PREVENTIVE MAINTENANCE SERVICE PLANS

Equipment Price	3-Year Plan	5-Year Plan
\$0.00 to \$1000.00	\$199.99	\$289.99
\$1001.00 to \$1500.00	\$259.99	\$379.99
\$1501.00 to \$2500.00	\$339.99	\$489.99
(Bikes/Systems Only) \$0.00 to \$2500.00	\$139.99	NA

Features:

- Includes an annual preventive maintenance and performance check at your convenience
- Unlimited in-home repairs; no shipping required
- Covers parts and labor on all manufacturer's defects, as well as wear and tear on parts
- Up to 5 years of coverage available

STANDARD SERVICE PLANS

Equipment Price	1-Year Plan	2-Year Plan	3-Year Plan
\$0.00 to \$300.00	\$29.99	\$39.99	\$59.99
\$301.00 to \$1000.00	\$89.99	\$119.99	\$149.99
\$1001.00 to \$2000.00	\$109.99	\$139.99	\$179.99
\$2001.00 to \$3000.00	\$179.99	\$209.99	\$239.99

Features:

- Unlimited in-home repairs; no shipping required
- Covers parts and labor on all manufacturer's defects, as well as wear and tear on parts
- Up to 3 years of coverage available

To protect your fitness equipment today, please
call Customer Care at **1-800-677-3838.**
Or, visit us online at **www.utserv.com.**



BEFORE YOU BEGIN

Thank you for selecting the revolutionary NORDICTRACK® VU 19 exercise bike. Cycling is one of the most effective exercises for increasing cardiovascular fitness, building endurance, and toning the entire body. The VU 19 exercise bike provides an impressive selection of features designed to make your workouts at home more effective and enjoyable.

For your benefit, read this manual carefully before you use the exercise bike. If you have questions after

reading this manual, please see the front cover of this manual. To help us assist you, note the product model number and serial number before contacting us. The model number and the location of the serial number decal are shown on the front cover of this manual.

Before reading further, please familiarize yourself with the parts that are labeled in the drawing below.

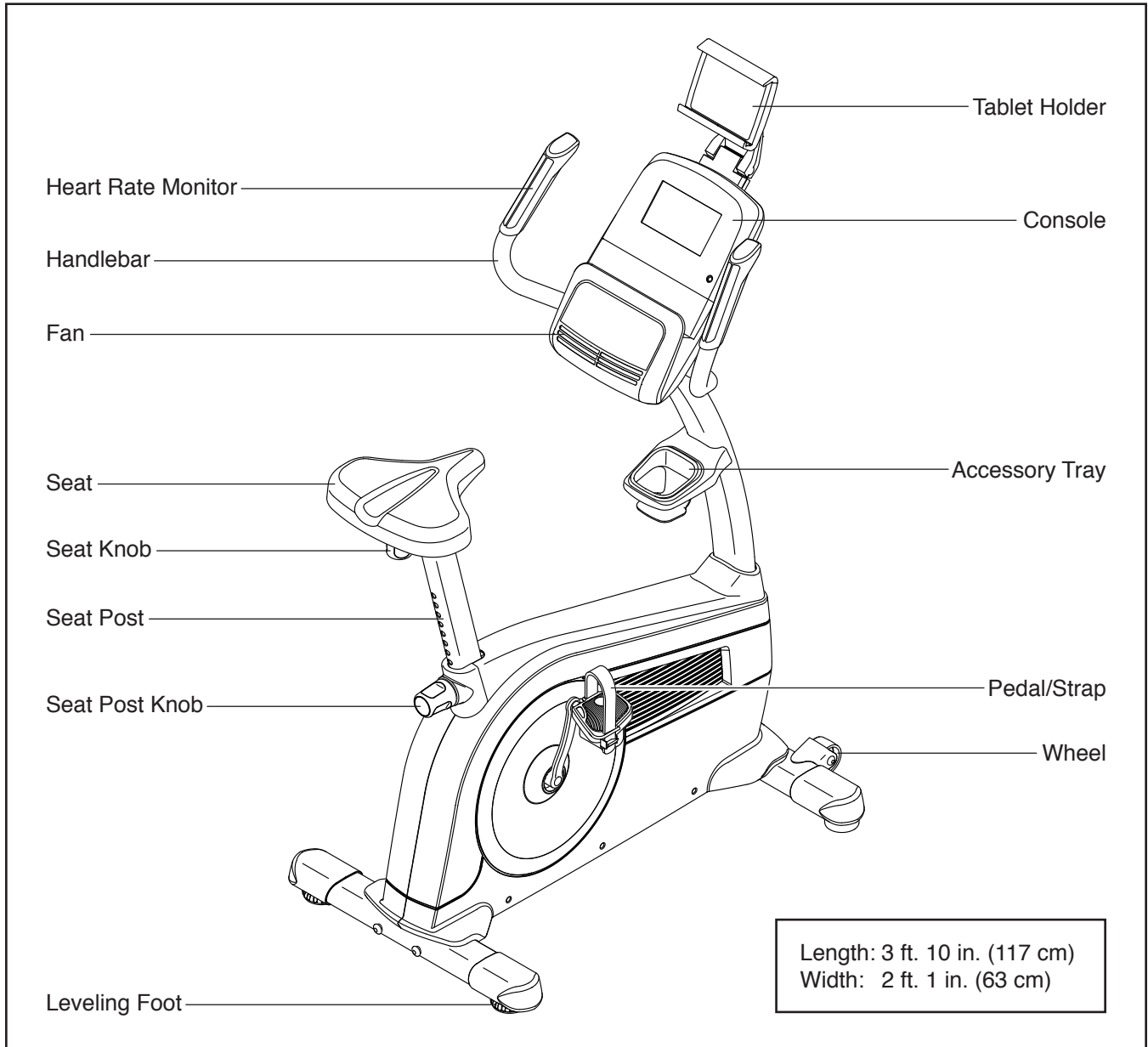

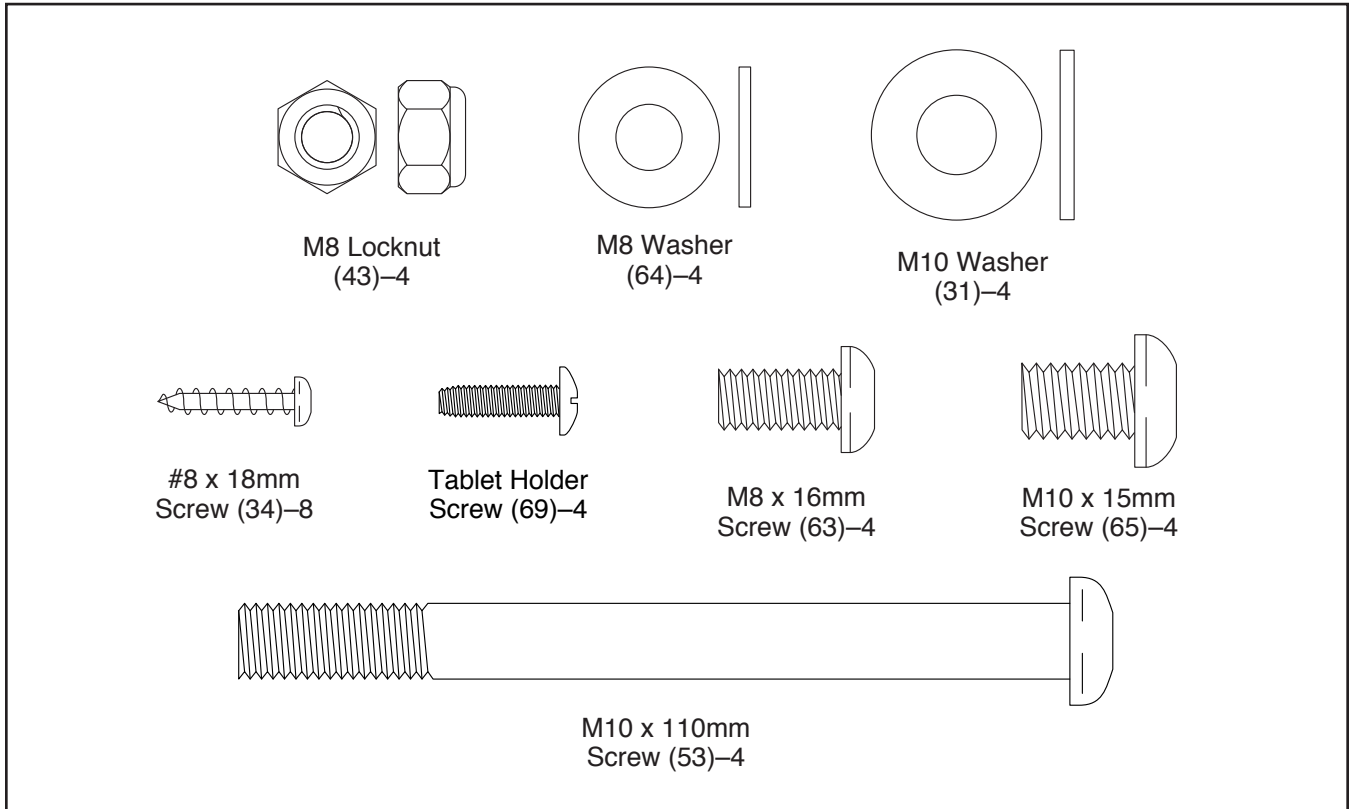

PART IDENTIFICATION CHART

Use the drawings below to identify the small parts needed for assembly. The number in parentheses below each drawing is the key number of the part, from the PART LIST near the end of this manual. The number following the key number is the quantity needed for assembly. **Note: If a part is not in the hardware kit, check to see whether it has been preassembled. Extra parts may be included.**

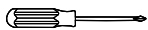

ASSEMBLY

- Assembly requires two persons.
 - Place all parts in a cleared area and remove the packing materials. Do not dispose of the packing materials until you finish all assembly steps.
 - Left parts are marked “L” or “Left” and right parts are marked “R” or “Right.”
 - To identify small parts, see page 6.
- In addition to the included tool(s), assembly requires the following tools:
 - one Phillips screwdriver 
 - one adjustable wrench 
- Assembly may be easier if you have a set of wrenches. To avoid damaging parts, do not use power tools.

1. **Go to my.nordictrack.com on your computer and register your product.**

- documents your ownership
- activates your warranty
- ensures priority customer support if assistance is ever needed

Note: If you do not have internet access, call Customer Care (see the front cover of this manual) and register your product.

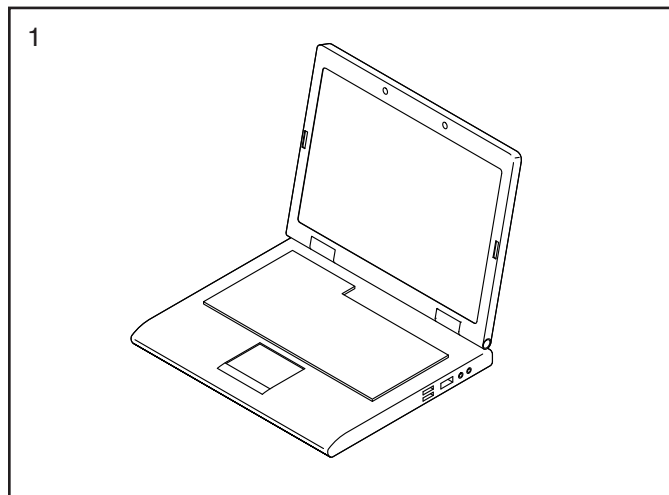

2. Identify the Front Stabilizer (2), and orient it as shown.

Attach the Front Stabilizer (2) to the Frame (1) with two M10 x 110mm Screws (53).

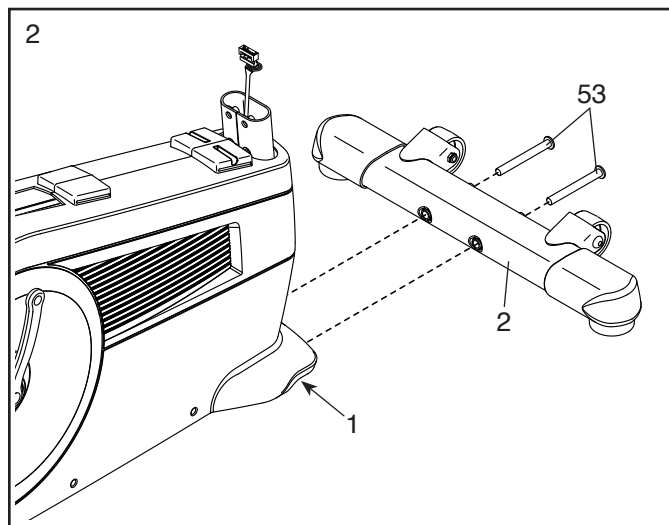

3. Attach the Rear Stabilizer (3) to the Frame (1) with two M10 x 110mm Screws (53).

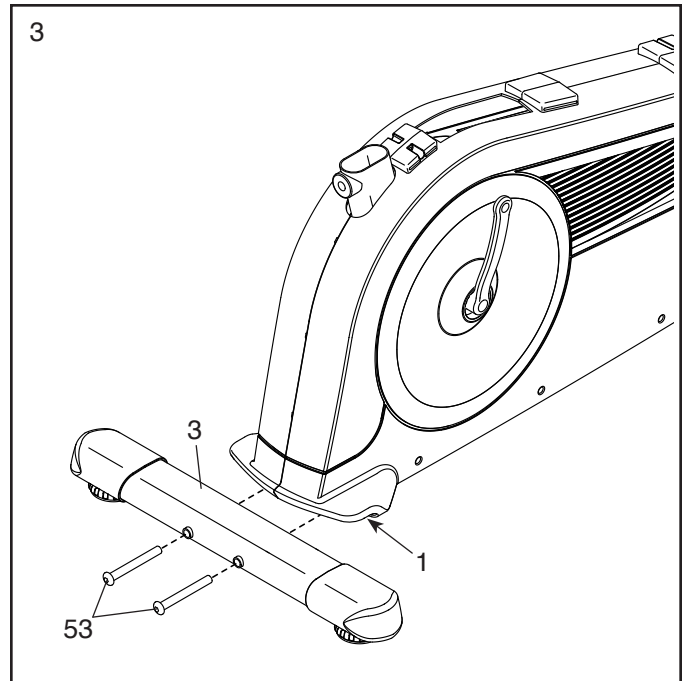

4. Orient the Upright (4) and the Shield Cover (7) as shown. Slide the Shield Cover upward onto the Upright.

Have a second person hold the Upright (4) and the Shield Cover (7) near the front of the Frame (1).

Next, locate the wire tie (A) inside the Upright (4). Tie the lower end of the wire tie to the Main Wire (58). Then, pull the upper end of the wire tie upward until the Main Wire is routed through the Upright.

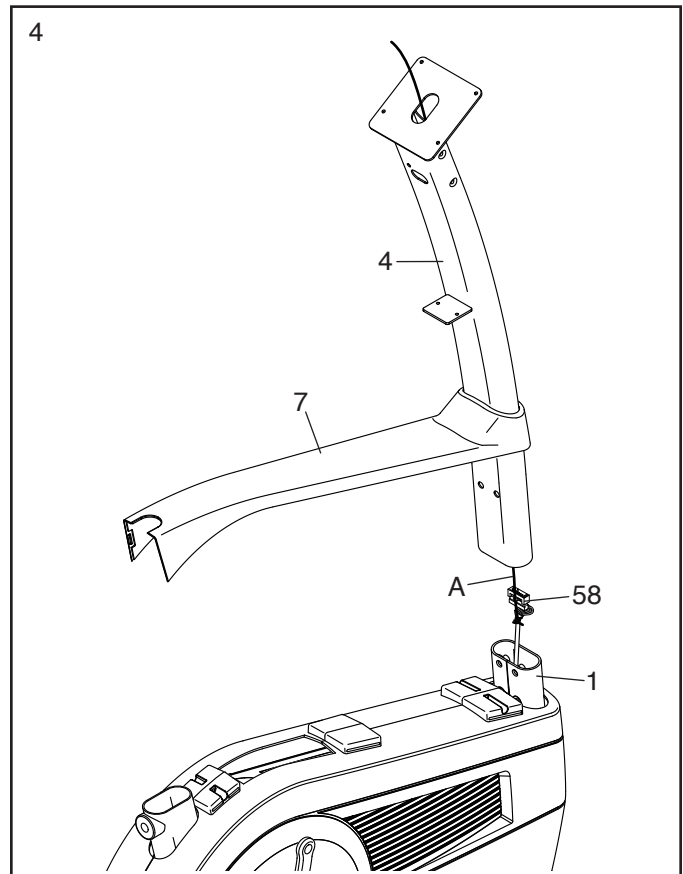

5. **Tip: Avoid pinching the wires.** Slide the Upright (4) onto the Frame (1).

Attach the Upright (4) with four M10 x 15mm Screws (65) and four M10 Washers (31); **start all the Screws, and then tighten them.**

Do not press the Shield Cover (7) into place yet.

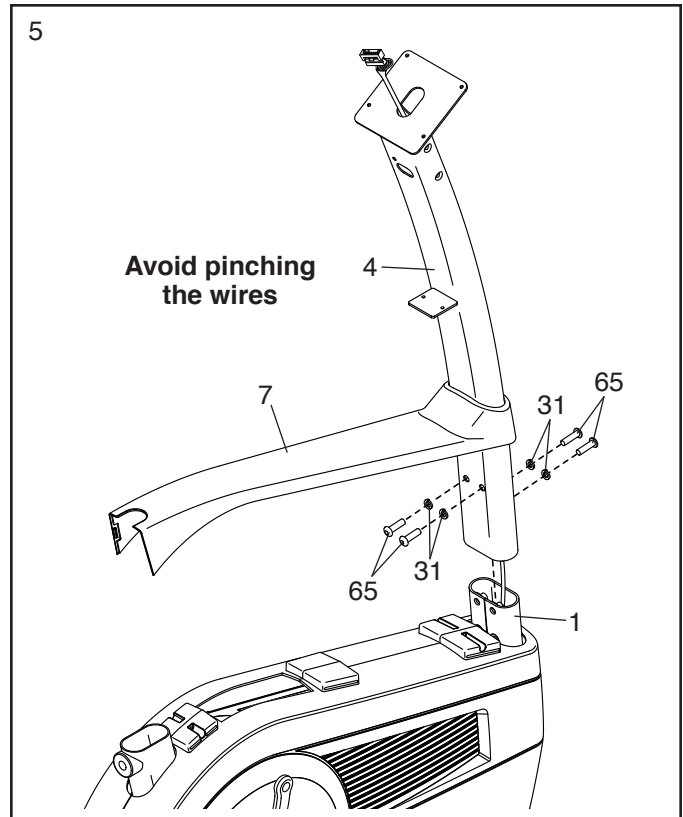

6. Orient the Seat Post (6) as shown, and insert it into the Frame (1).

Then, slide the Shield Cover (7) downward and press it onto the Right and Left Shields (10, 11).

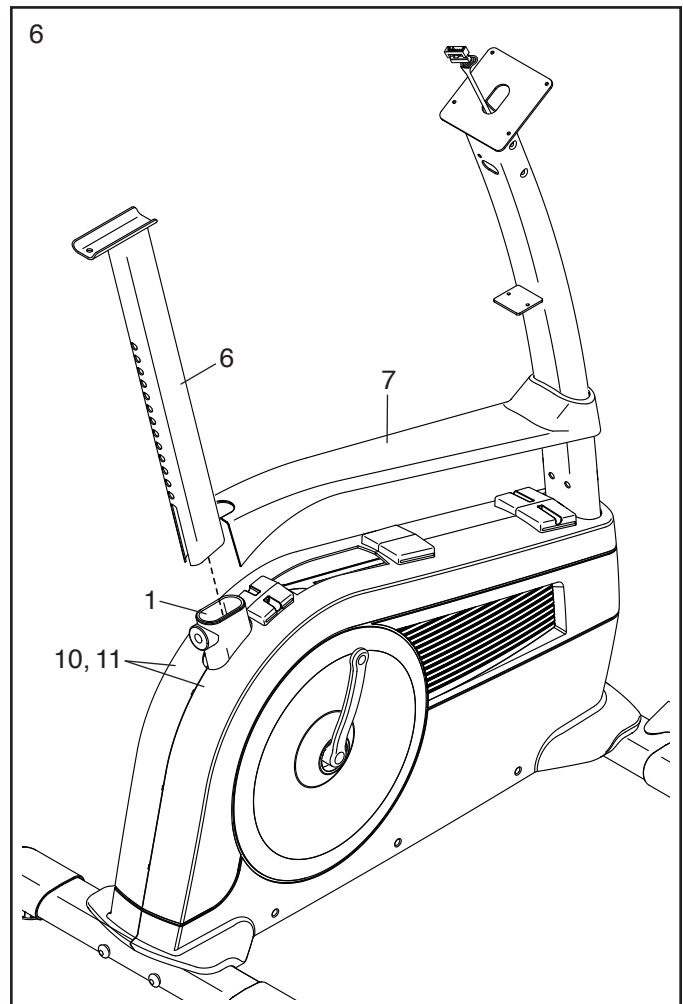

7. Orient the Knob Shield (9) as shown, and press it onto the Shield Cover (7).

Then, tighten the Seat Post Knob (27) into the Frame (1).

Next, loosen and pull the Seat Post Knob (27), slide the Seat Post (6) upward or downward to the desired position, and then release the Seat Post Knob. **Move the Seat Post upward or downward slightly to make sure that the Seat Post Knob is engaged in one of the adjustment holes in the Seat Post.** Then, tighten the Seat Post Knob.

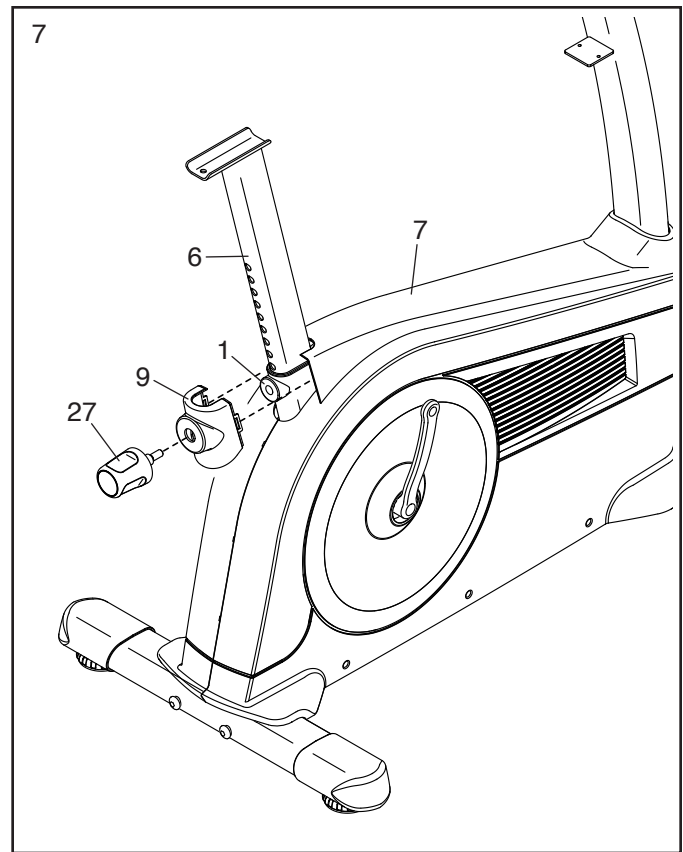

8. Attach the Seat (23) to the Seat Carriage (24) with four M8 Locknuts (43) and four M8 Washers (64). **Note: The Locknuts and Washers may be preattached to the Seat.**

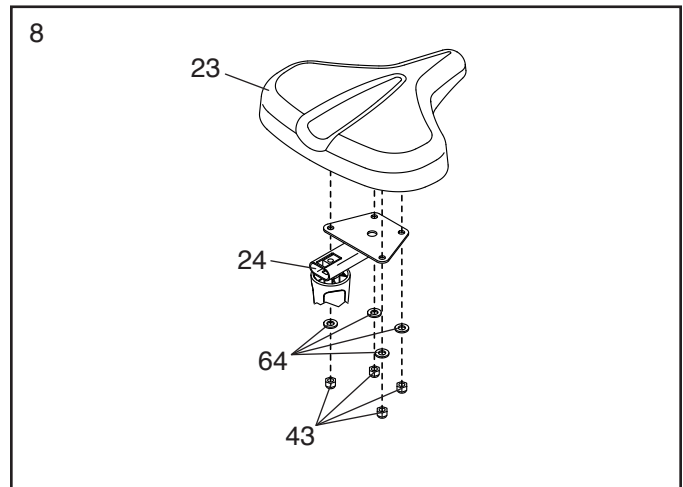

9. Remove the Seat Knob (26) from the Seat Bracket (30) inside the Seat Carriage (24).

Next, set the Seat Carriage (24) on the Seat Post (6). Then, insert the Seat Knob (26) upward into the Seat Post, and tighten the Seat Knob into the Seat Bracket (30) inside the Seat Carriage.

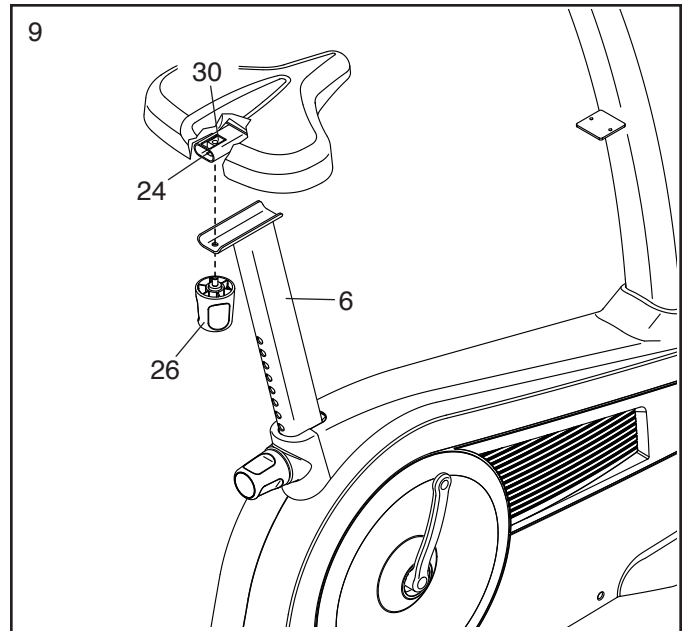

10. While a second person holds the Console (13) near the Upright (4), connect the Main Wire (58) to the matching wire on the Console.

Next, insert the other wires (B) on the Console (13) downward through the large opening in the Upright (4).

Insert the excess wire into the Upright (4).

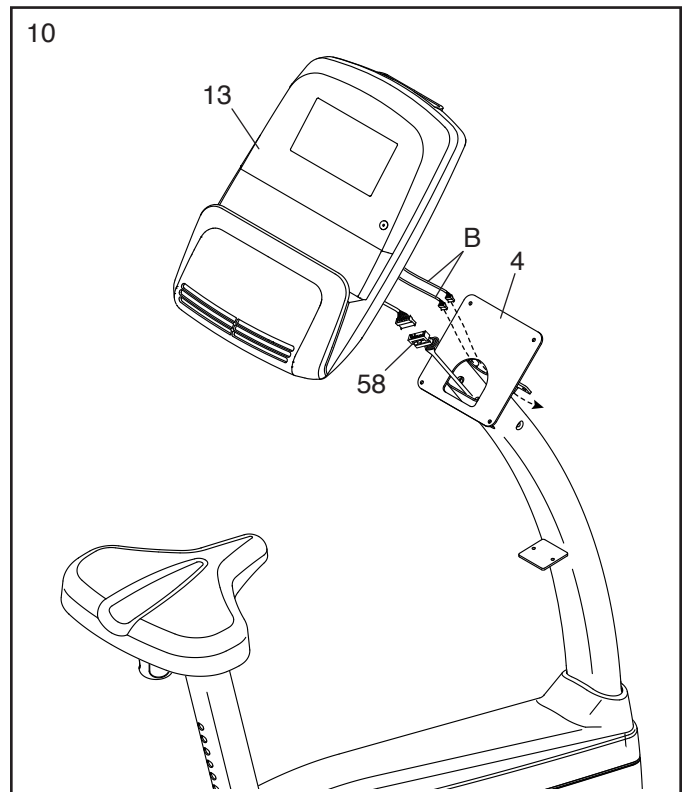

11. **Tip: Avoid pinching the wires.** Attach the Console (13) to the Upright (4) with four #8 x 18mm Screws (34); **start all the Screws, and then tighten them.**

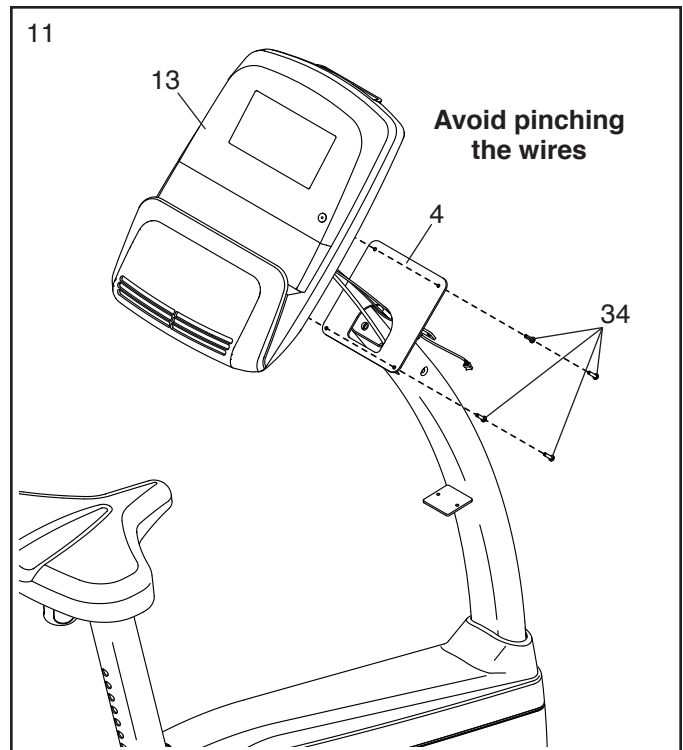

12. Have a second person hold the Right Handlebar (5) near the Upright (4).

Connect the Pulse Wire (61) in the Right Handlebar (5) to the matching wire on the Console (13).

Tip: Avoid pinching the wires. Attach the Right Handlebar (5) to the Upright (4) with two M8 x 16mm Screws (63); **start both Screws, and then tighten them.**

Repeat this step with the Left Handlebar (14).

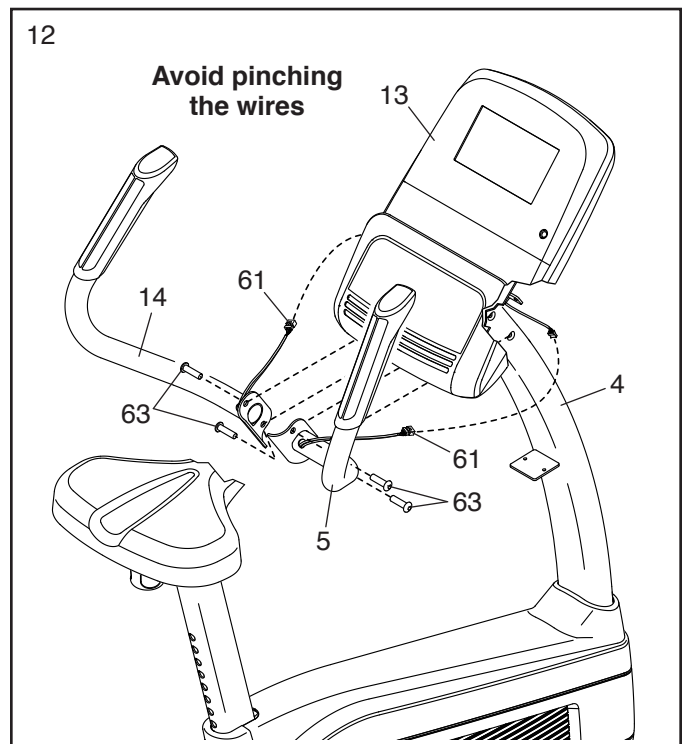

13. **Note: For clarity, the console is not shown in this step.**

Attach the Front Console Cover (12) to the Upright (4) with two #8 x 18mm Screws (34).

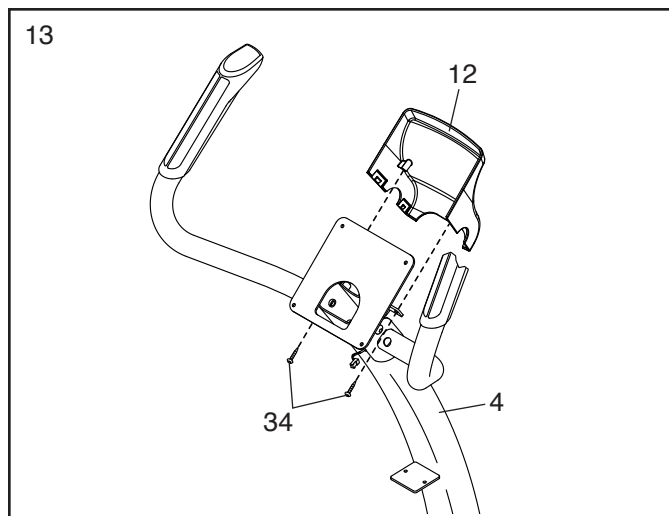

14. **Note: For clarity, the console is not shown in this step.**

Press the Rear Console Cover (15) onto the Front Console Cover (12).

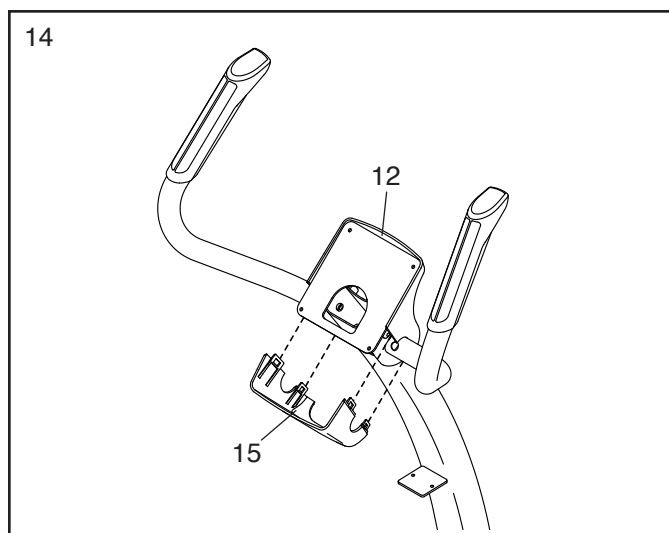

15. Attach the Accessory Tray (8) to the Upright (4) with two #8 x 18mm Screws (34).

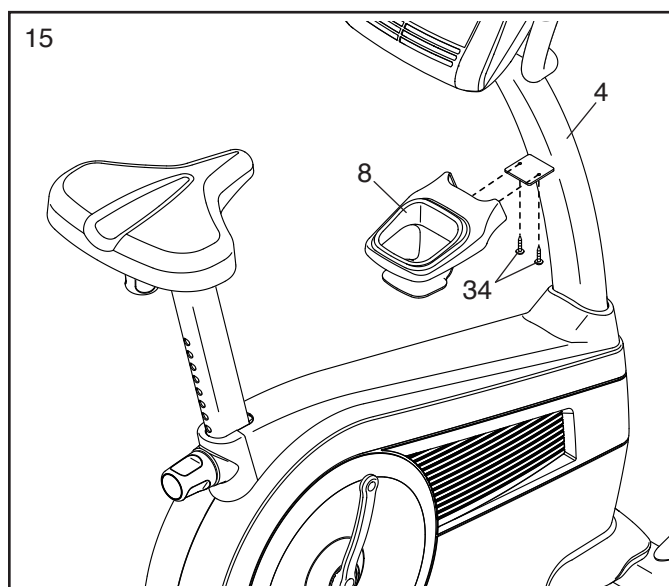

16. Identify the Right Pedal (21). Using an adjustable wrench, **firmly tighten** the Right Pedal **clockwise** into the Right Crank Arm (19).

Firmly tighten the Left Pedal (not shown) counterclockwise into the Left Crank Arm (not shown). IMPORTANT: You must turn the Left Pedal counterclockwise to attach it.

To adjust the pedal straps (C), see HOW TO ADJUST THE PEDAL STRAPS on page 16.

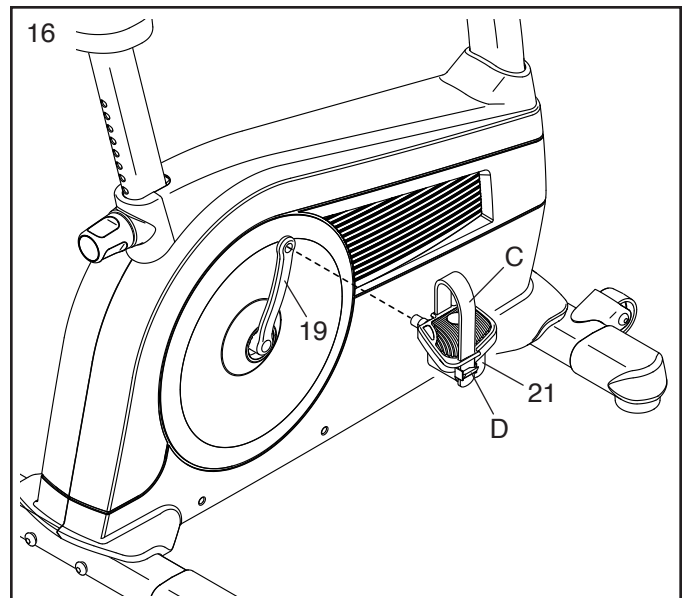

17. Attach the Tablet Holder (16) to the Console (13) with four Tablet Holder Screws (69); **start all the Tablet Holder Screws, and then tighten them.**

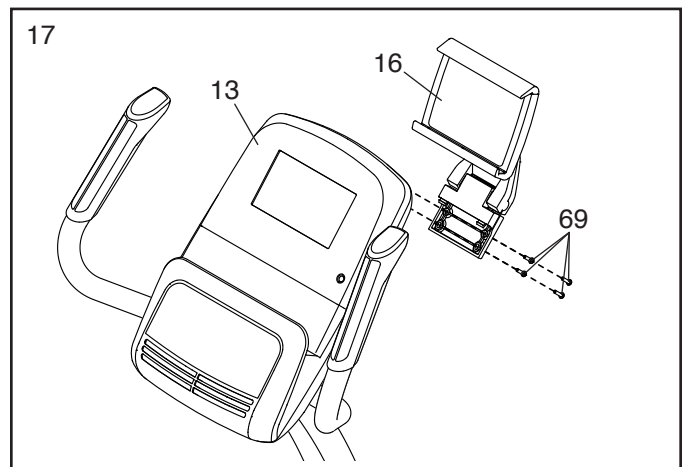

18. Plug the Power Adapter (67) into the Power Receptacle (29) on the front of the exercise bike.

Note: To plug the Power Adapter (67) into an outlet, see HOW TO PLUG IN THE POWER ADAPTER on page 16.

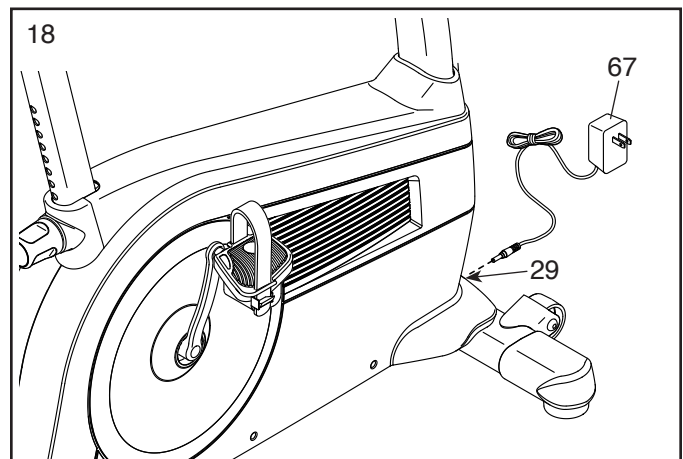

19. **After the exercise bike is assembled, inspect it to make sure that it is assembled correctly and that it functions properly. Make sure that all parts are properly tightened before you use the exercise bike.** Extra parts may be included. Place a mat under the exercise bike to protect the floor or carpet.

THE CHEST HEART RATE MONITOR

HOW TO PUT ON THE HEART RATE MONITOR

If the heart rate monitor looks like the one shown in drawing 1, press the transmitter (A) onto the snap fasteners on the chest strap (B). If the heart rate monitor looks like the one shown in drawing 2, insert the tab (C) on one end of the chest strap (D) into one end of the transmitter (E). Then, press the end of the transmitter under the buckle (F) on the chest strap; the tab should be flush with the transmitter.

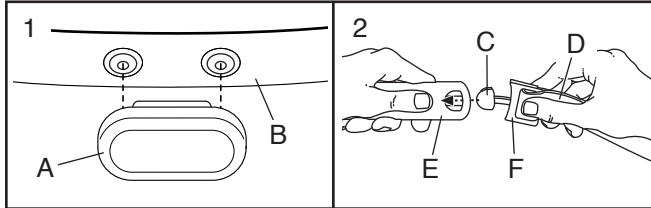

Next, wrap the heart rate monitor around your chest in the location shown; the heart rate monitor must be under your clothes, tight against your skin. Make sure that the logo is right-side-up. Then, attach the other end of the chest strap. Adjust the length of the chest strap, if necessary.

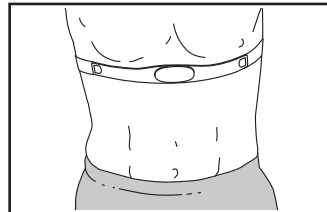

Next, pull the transmitter and the chest strap away from your body a few inches and locate the two electrode areas (G). Using saliva or contact lens solution, wet the electrode areas. Then, return the transmitter and the chest strap to a position against your chest.

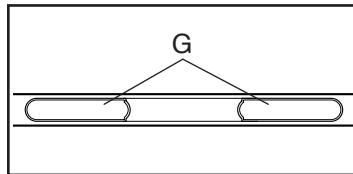

CARE AND MAINTENANCE

- Thoroughly dry the electrode areas with a soft towel after each use. Moisture may keep the heart rate monitor activated, shortening the life of the battery.
- Store the heart rate monitor in a warm, dry place. Do not store the heart rate monitor in a plastic bag or other container that may trap moisture.
- Do not expose the heart rate monitor to direct sunlight for extended periods of time, and do not expose it to temperatures above 122°F (50°C) or below 14°F (-10°C).
- Do not excessively bend or stretch the heart rate monitor when using or storing it.
- To clean the transmitter, use a damp cloth and a small amount of mild soap. Then, wipe the transmitter with a damp cloth and thoroughly dry it with a soft towel. Never use alcohol, abrasives, or chemicals to clean the transmitter. Hand wash and air dry the chest strap.

TROUBLESHOOTING

- If the heart rate monitor does not function when positioned as described at the left, move it slightly lower or higher on your chest.
- If heart rate readings are not displayed until you begin perspiring, re-wet the electrode areas.
- For the console to display heart rate readings, you must be within arm's length of the console.
- If there is a battery cover on the back of the transmitter, replace the battery with a new battery of the same type.
- The heart rate monitor is designed to work with people who have normal heart rhythms. Heart rate reading problems may be caused by medical conditions such as premature ventricular contractions (pvc's), tachycardia bursts, and arrhythmia.
- The operation of the heart rate monitor can be affected by magnetic interference from high power lines or other sources. If you suspect that magnetic interference is causing a problem, try relocating the fitness equipment.

HOW TO USE THE EXERCISE BIKE

HOW TO PLUG IN THE POWER ADAPTER

IMPORTANT: If the exercise bike has been exposed to cold temperatures, allow it to warm to room temperature before you plug in the power adapter. If you do not do this, you may damage the console displays or other electronic components.

Plug the power adapter (A) into the receptacle on the frame of the exercise bike. Then, plug the power adapter into an appropriate outlet that is properly installed in accordance with all local codes and ordinances.

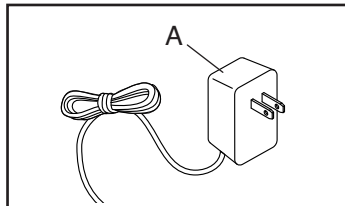

HOW TO ADJUST THE HEIGHT OF THE SEAT

For effective exercise, the seat should be at the proper height. As you pedal, there should be a slight bend in your knees when the pedals are in the lowest position.

To adjust the seat, loosen the seat post knob (B) a few turns, pull the knob, slide the seat post upward or downward to the desired position, and then release the knob. **Move the seat post upward or downward slightly to make sure that the knob is engaged in one of the adjustment holes in the seat post.** Then, tighten the knob.

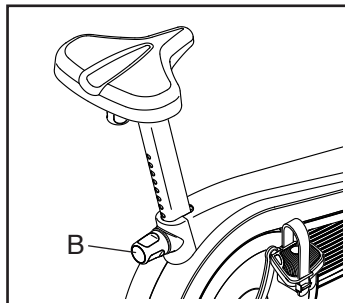

HOW TO ADJUST THE LATERAL POSITION OF THE SEAT

To adjust the lateral position of the seat, first loosen the seat knob (C) a few turns. Then, move the seat forward or backward to the desired position, and firmly tighten the seat knob.

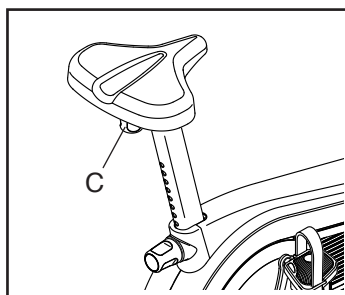

HOW TO ADJUST THE PEDAL STRAPS

To tighten a pedal strap (D), pull downward on the end of the strap. To loosen a strap, press the tab (E) and pull upward on the strap.

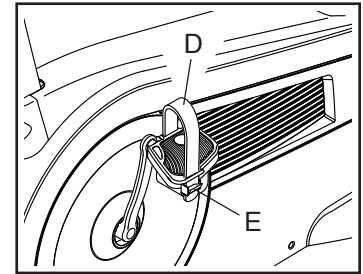

HOW TO LEVEL THE EXERCISE BIKE

If the exercise bike rocks slightly on your floor during use, turn one or both of the leveling feet (F) beneath the rear stabilizer until the rocking motion is eliminated.

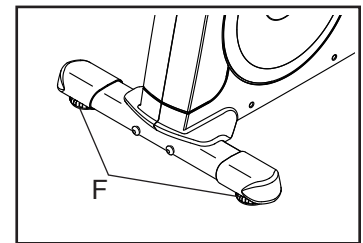

HOW TO USE THE TABLET HOLDER

IMPORTANT: The tablet holder (G) is designed for use with most full-size tablets. Do not place any other electronic device or object in the tablet holder.

To insert a tablet into the tablet holder (G), set the bottom edge of the tablet in the tray. Then, pull the clip on the top of the tablet holder over the top edge of the tablet. **Make sure that the tablet is firmly secured in the tablet**

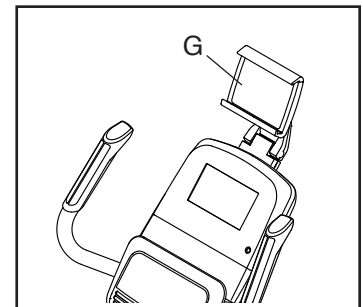

holder. If applicable to your tablet holder model, rotate and/or pivot the tablet holder to the desired position. Reverse these actions to remove the tablet from the tablet holder.

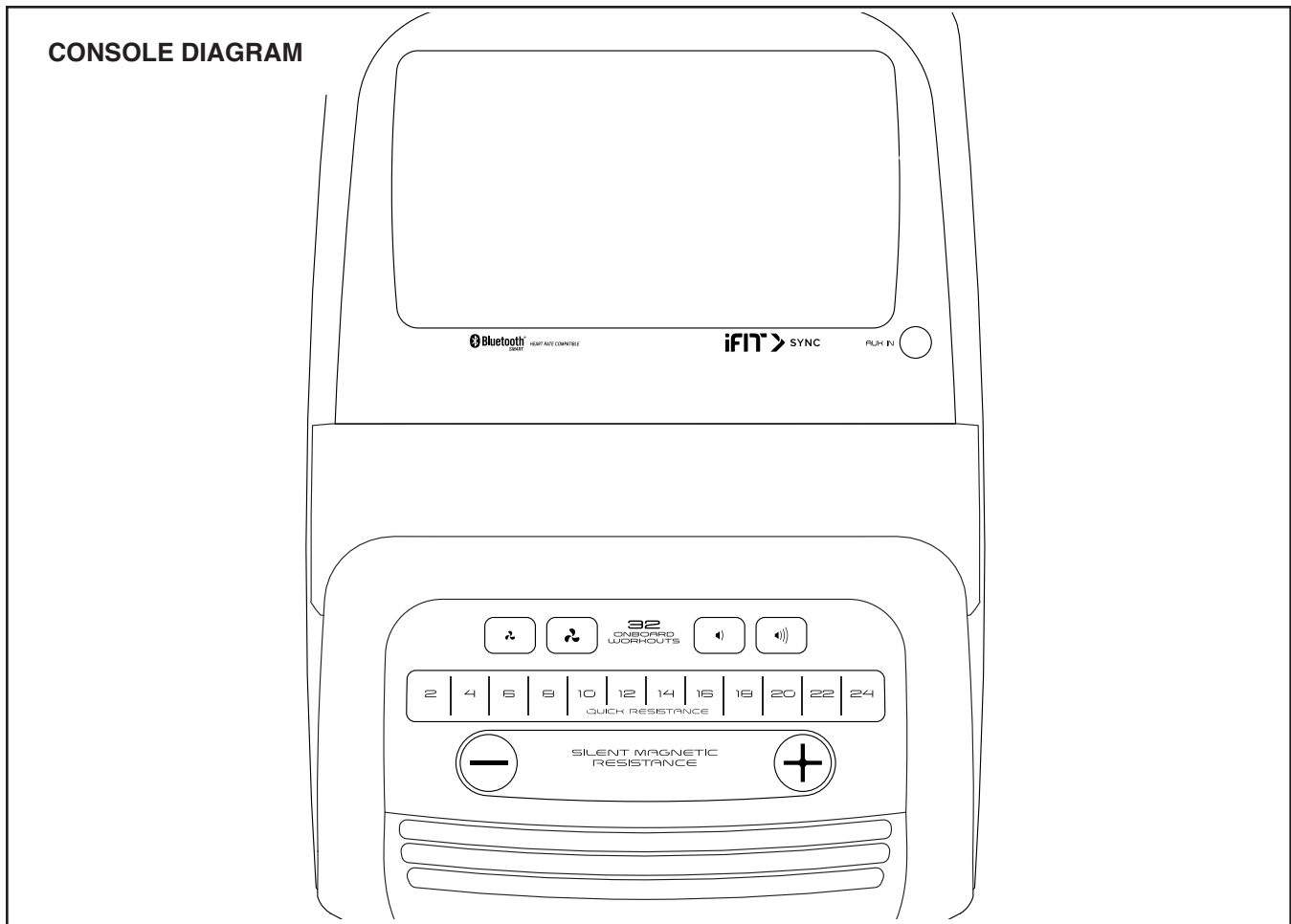

FEATURES OF THE CONSOLE

The advanced console offers an array of features designed to make your workouts more effective and enjoyable.

The console features wireless technology that enables the console to connect to iFit. With iFit, you can access a large and varied workout library, create your own workouts, track your workout results, and access many other features.

In addition, the console features a selection of onboard workouts. Each workout automatically controls the resistance of the pedals as it guides you through an effective exercise session.

When you use the manual mode of the console, you can change the resistance of the pedals with the touch of a button.

While you exercise, the console will display continuous exercise feedback. You can even measure your heart rate using the handgrip heart rate monitor or the included chest heart rate monitor.

You can also listen to your favorite workout music or audio books with the console sound system while you exercise.

To turn on and turn off the console, see page 18. **To learn how to use the touch screen**, see page 18. **To set up the console**, see page 19.

HOW TO TURN ON THE CONSOLE

The included power adapter must be used to operate the exercise bike. See HOW TO PLUG IN THE POWER ADAPTER on page 16. When the power adapter is plugged in, touch the screen or press any button on the console to turn on the console.

HOW TO TURN OFF THE CONSOLE

If the pedals do not move for several seconds, the console will pause.

If the pedals do not move for several minutes, the screen is not touched, and the buttons are not pressed, the console will turn off.

When you are finished exercising, unplug the power adapter. **IMPORTANT: If you do not do this, the electrical components on the exercise bike may wear prematurely.**

HOW TO USE THE TOUCH SCREEN

The console features a tablet with a full-color touch screen. The following information will help you use the touch screen:

- The console functions similarly to other tablets. You can slide or flick your finger against the screen to move certain images on the screen, such as the displays in a workout.
- To type information into a text box, first touch the text box to view the keyboard. To use numbers or other characters on the keyboard, touch *?123*. To view more characters, touch *Alt*. Touch *Alt* again to return to the number keyboard. To return to the letter keyboard, touch *ABC*. To use a capital character, touch the shift button (upward-facing arrow symbol). To use multiple capital characters, touch the shift button again. To return to the lowercase keyboard, touch the shift button a third time. To clear the last character, touch the clear button (backward-facing arrow with an X symbol).

HOW TO SET UP THE CONSOLE

Before you use the exercise bike for the first time, set up the console.

1. Connect to your wireless network.

To use iFit workouts and to use several other features of the console, the console must be connected to a wireless network. Follow the prompts on the screen to connect the console to your wireless network.

2. Customize settings.

Follow the prompts on the screen to set the desired unit of measurement and your time zone.

Note: To change these settings later, see HOW TO CHANGE CONSOLE SETTINGS on page 25.

3. Log into or create an iFit account.

Follow the prompts on the screen to log into your iFit account or to create an iFit account.

4. Tour the console.

The first time you use the console, a tour presentation will guide you through the features of the console. Note: To view the tour presentation again at any time, touch the profile button (person symbol) at the bottom of the screen, touch *Settings*, and then touch *How It Works*.

5. Check for firmware updates.

First, touch the profile button, touch *Settings*, touch *Maintenance*, and then touch *Update*. The console will check for firmware updates. For more information, see HOW TO CHANGE CONSOLE SETTINGS on page 25.

The console is now ready for you to begin working out. The following pages explain the workouts and other features that the console offers.

To use the manual mode, see this page. To use a map workout or an onboard workout, see page 21. To create a draw-your-own-map workout, see page 23. To use an iFit workout, see page 24.

To change console settings, see page 25. To connect to a wireless network, see page 26. To use the sound system, see page 27. To connect to the sound system with BLUETOOTH, see page 27. To connect an HDMI cable, see page 27.

Note: If there is a sheet of plastic on the screen, remove the plastic.

HOW TO USE THE MANUAL MODE

1. Touch the screen or press any button on the console to turn on the console.

See HOW TO TURN ON THE CONSOLE on page 18. Note: It may take a few moments for the console to be ready for use.

2. Select the main menu.

When you turn on the console, the main menu will appear on the screen after the console boots up.

If you are in a workout, touch the screen, touch *Pause*, touch *End*, and then touch *Finish* to return to the main menu. If you are in the settings menus, touch the back button (arrow symbol) and then touch the close button (x symbol) to return to the main menu.

3. Change the resistance of the pedals as desired.

Touch *Manual Start* and begin pedaling.

You can change the resistance of the pedals by pressing one of the numbered Quick Resistance buttons or by pressing the Silent Magnetic Resistance increase and decrease buttons.

Note: After you press a button, it will take a moment for the pedals to reach the selected resistance level.

4. Follow your progress.

The console offers several display modes. The display mode that you select will determine which workout information is shown.

To select the desired display mode or to view statistics and charts, drag downward on the screen. You can also touch the more button (+ symbol) to view statistics or charts.

If desired, adjust the volume level by pressing the volume increase and decrease buttons.

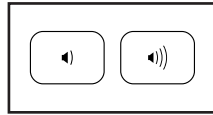

To pause the workout, simply touch the screen or stop pedaling. To continue the workout, simply resume pedaling.

To end the workout session, first touch the screen to pause the workout. Next, touch *End*; a workout summary will appear on the screen. If desired, you can publish your results using one of the options on the screen. Then, touch *Finish* to return to the main menu.

5. Measure your heart rate if desired.

You can measure your heart rate using either the handgrip heart rate monitor or the included chest heart rate monitor. Note: The console is compatible with all BLUETOOTH® Smart heart rate monitors.

To use the chest heart rate monitor, see page 15. To use the handgrip heart rate monitor, follow the instructions at the right. **Note: If you use both heart rate monitors at the same time, the chest heart rate monitor will have priority.**

If there are sheets of plastic on the metal contacts (A) on the handgrip heart rate monitor, remove the plastic. To measure your heart rate, hold the handgrip heart rate monitor

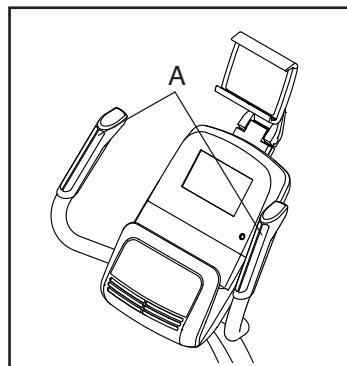

with your palms resting against the contacts. **Avoid moving your hands or gripping the contacts tightly.**

When your pulse is detected, your heart rate will be shown. For the most accurate heart rate reading, hold the contacts for at least 15 seconds.

If the display does not show your heart rate, make sure that your hands are positioned as described. Be careful not to move your hands excessively or to squeeze the contacts tightly. For optimal performance, clean the contacts using a soft cloth; **never use alcohol, abrasives, or chemicals to clean the contacts.**

6. Turn on the fan if desired.

The fan has several speed settings, including an auto mode. While the auto mode is selected, the speed of the fan will automatically increase or decrease as your pedaling speed increases or decreases. Press the fan increase and decrease buttons repeatedly to select a fan speed or to turn off the fan.

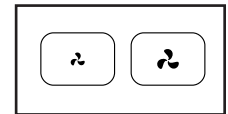

Note: If the pedals are not moved for a while when the main menu is selected, the fan will turn off automatically.

7. When you are finished exercising, the console will turn off automatically.

See HOW TO TURN OFF THE CONSOLE on page 18.

HOW TO USE A MAP WORKOUT OR AN ONBOARD WORKOUT

1. Touch the screen or press any button on the console to turn on the console.

See HOW TO TURN ON THE CONSOLE on page 18. Note: It may take a few moments for the console to be ready for use.

2. Select the main menu or the workout library.

When you turn on the console, the main menu will appear on the screen after the console boots up.

If you are in a workout, touch the screen, touch *Pause*, touch *End*, and then touch *Finish* to return to the main menu. If you are in the settings menus, touch the back button (arrow symbol) and then touch the close button (x symbol) to return to the main menu.

Touch the buttons at the bottom of the screen to select either the main menu (B) or the workout library (C).

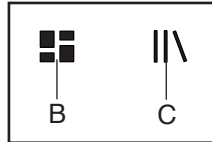

3. Select a workout.

To select a workout from the main menu or the workout library, simply touch the desired workout button on the screen. Slide or flick the screen to scroll upward or downward if necessary.

Note: To use a map workout, the console must be connected to a wireless network (see HOW TO CONNECT TO A WIRELESS NETWORK on page 26).

The featured map workouts on your console will change periodically. To save one of the featured map workouts for future use, you can add it as a favorite by touching the favorites button (heart

symbol). You must be logged into your iFit account to save a featured map workout (see step 3 on page 24).

To draw your own map for a workout, see HOW TO CREATE A DRAW-YOUR-OWN-MAP WORKOUT on page 23.

When you select a workout, the screen will show an overview of the workout that includes details such as the duration and distance of the workout and the approximate number of calories you will burn during the workout.

4. Start the workout.

Touch *Start* to start the workout.

During some workouts, the screen will show a map of the route and a marker indicating your progress. Touch the buttons on the screen to select the desired map options.

The display modes will also show your progress. To select the desired display mode or to view statistics and charts, swipe downward on the screen. You can also touch the more button (+ symbol) to view statistics or charts.

The workout will function in the same way as the manual mode (see page 19).

During some workouts, the screen may show a target speed. As you exercise, keep your pedaling speed near the target speed shown on the screen. A message may appear prompting you to increase, decrease, or maintain your pedaling speed.

IMPORTANT: The target speed is intended only to provide motivation. Your actual pedaling speed may be slower than the target speed. Make sure to pedal at a speed that is comfortable for you.

If the resistance level is too high or too low, you can manually override the setting by pressing the Resistance buttons. **If you press a Resistance button**, you can then manually control the resistance level (see step 3 on page 19). **To return to the programmed resistance settings of the workout**, touch *Follow Workout*.

Note: The calorie goal shown in the workout description is an estimate of the number of calories that you will burn during the workout. The actual number of calories that you burn will depend on various factors, such as your weight. In addition, if you manually change the resistance level during the workout, the number of calories you burn will be affected.

To pause the workout, simply touch the screen or stop pedaling. To end the workout, touch *End*. To continue the workout, simply resume pedaling.

When the workout comes to an end, a workout summary will appear on the screen. If desired, you

can publish your results using one of the options on the screen. Then, touch *Finish* to return to the main menu.

5. Follow your progress.

See step 4 on page 20.

6. Measure your heart rate if desired.

See step 5 on page 20.

7. Turn on the fan if desired.

See step 6 on page 20.

8. When you are finished exercising, the console will turn off automatically.

See HOW TO TURN OFF THE CONSOLE on page 18.

HOW TO CREATE A DRAW-YOUR-OWN-MAP WORKOUT

1. Touch the screen or press any button on the console to turn on the console.

See HOW TO TURN ON THE CONSOLE on page 18. Note: It may take a few moments for the console to be ready for use.

2. Select a draw-your-own-map workout.

When you turn on the console, the main menu will appear on the screen after the console boots up.

If you are in a workout, touch the screen, touch *Pause*, touch *End*, and then touch *Finish* to return to the main menu. If you are in the settings menus, touch the back button (arrow symbol) and then touch the close button (x symbol) to return to the main menu.

To select a draw-your-own-map workout, touch the draw-your-own-map button (map symbol) at the bottom of the screen.

3. Draw your map.

Navigate to the area on the map where you want to draw your workout by sliding your fingers on the screen. Touch the screen to add the start point for your workout. Then, touch the screen to add the end point for your workout.

If you want to start and end your workout at the same point, touch *Loop* or *Out & Back* on the left side of the screen. You can also select whether you want your workout to snap to the road.

If you make a mistake, touch *Undo* on the left side of the screen.

The screen will display the elevation and distance statistics for your workout.

4. Save your workout.

Touch *Save New Workout* to save your workout. If desired, enter a title and description for your workout. Then, touch the continue button (> symbol).

5. Start the workout.

Touch *Start* to start the workout. The workout will function in the same way as a map workout or an onboard workout (see page 21).

6. Follow your progress.

See step 4 on page 20.

7. Measure your heart rate if desired.

See step 5 on page 20.

8. Turn on the fan if desired.

See step 6 on page 20.

9. When you are finished exercising, the console will turn off automatically.

See HOW TO TURN OFF THE CONSOLE on page 18.

HOW TO USE AN iFIT WORKOUT

To use an iFit workout, the console must be connected to a wireless network (see HOW TO CONNECT TO A WIRELESS NETWORK on page 26). An iFit account is also required.

1. Add workouts to your schedule on iFit.com.

On your computer, smartphone, tablet, or other device, open an internet browser, go to iFit.com, and log in to your iFit account.

Next, navigate to Menu > Library on the website. Browse the workout programs in the library and join the desired workouts.

Then, navigate to Menu > Schedule to view your schedule. All of the workouts that you have joined will appear on your schedule; you can arrange or delete the workouts on your schedule as desired.

Take time to explore the iFit.com website before you log out.

2. Select the main menu.

When you turn on the console, the main menu will appear on the screen after the console boots up.

If you are in a workout, touch the screen, touch *Pause*, touch *End*, and then touch *Finish* to return to the main menu. If you are in the settings menus, touch the back button (arrow symbol) and then touch the close button (x symbol) to return to the main menu.

3. Log in to your iFit account.

If you have not already done so, touch the profile button (person symbol) at the bottom of the screen to log in to your iFit account. Follow the prompts on the screen to enter your username and password.

To switch users within your iFit account, touch the profile button, and then touch *Manage Accounts*. If more than one user is associated with the account, a list of users will appear. Touch the name of the desired user.

4. Select an iFit workout that you have previously added to your schedule on iFit.com.

IMPORTANT: Before iFit workouts will load, you must add them to your schedule on iFit.com (see step 1).

To load an iFit workout from iFit.com to the console, touch the calendar button (calendar symbol) at the bottom of the screen.

When you load a workout, the screen will show an overview of the workout that includes details such as the duration and distance of the workout and the approximate number of calories you will burn during the workout.

5. Start the workout.

Touch *Start* to start the workout. The workout will function in the same way as a map workout or an onboard workout (see page 21). Note: During a distance or time workout, the screen will not show a map.

6. Follow your progress.

See step 4 on page 20.

7. Measure your heart rate if desired.

See step 5 on page 20.

8. Turn on the fan if desired.

See step 6 on page 20.

9. When you are finished exercising, the console will turn off automatically.

See HOW TO TURN OFF THE CONSOLE on page 18.

For more information about iFit, go to iFit.com.

HOW TO CHANGE CONSOLE SETTINGS

IMPORTANT: Some of the settings and features described may not be enabled. Occasionally, a firmware update may cause your console to function slightly differently.

1. Select the settings main menu.

First, turn on the power (see HOW TO TURN ON THE CONSOLE on page 18). Note: It may take a few moments for the console to be ready for use.

Next, select the main menu. When you turn on the console, the main menu will appear on the screen after the console boots up. If you are in a workout, touch the screen, touch *Pause*, touch *End*, and then touch *Finish* to return to the main menu.

Next, touch the profile button (person symbol) at the bottom of the screen, and then touch *Settings*. The settings menu will appear on the screen.

2. Navigate the settings menus and change settings as desired.

Slide or flick the screen to scroll upward or downward if necessary. To view a settings menu, simply touch the menu name. To exit a menu, touch the back button (arrow symbol). You may be able to view and change settings in the following settings menus:

Account

- My Profile
- In Workout
- Manage Accounts

Equipment

- Equipment Info
- Equipment Settings
- Maintenance
- Wi-Fi

About

- How It Works
- Feedback
- Legal

3. View the console tour presentation.

To view a tour presentation that will guide you through the features of the console, touch *How It Works*.

4. Customize the unit of measurement and other settings.

To customize the unit of measurement, the time zone, or other settings, touch *Equipment Settings*, and then touch the desired settings.

The console can display speed and distance in either standard or metric units of measurement.

5. View machine information.

Touch *Equipment Info*, and then touch *Machine Info* to view information about your exercise bike.

6. Update the console firmware.

For the best results, regularly check for firmware updates. Touch *Maintenance*, and then touch *Update* to check for firmware updates using your wireless network. The update will begin automatically. **IMPORTANT: To avoid damaging the exercise bike, do not unplug the power adapter while the firmware is being updated.**

The screen will show the progress of the update. When the update is complete, the exercise bike will turn off and then turn back on. If it does not, unplug the power adapter. Wait for several seconds, and then plug in the power adapter. Note: It may take a few minutes for the console to be ready for use.

Note: Occasionally, a firmware update may cause the console to function slightly differently. These updates are always designed to improve your exercise experience.

7. Exit the settings main menu.

If you are in a settings menu, touch the back button. Then, touch the close button (x symbol) to exit the settings main menu.

HOW TO CONNECT TO A WIRELESS NETWORK

To use iFit workouts and to use several other features of the console, the console must be connected to a wireless network.

1. Select the main menu.

First, turn on the power (see HOW TO TURN ON THE CONSOLE on page 18). Note: It may take a few moments for the console to be ready for use.

Next, select the main menu. When you turn on the console, the main menu will appear on the screen after the console boots up. If you are in a workout, touch the screen, touch *Pause*, touch *End*, and then touch *Finish* to return to the main menu.

2. Select the wireless network menu.

Touch the Wi-Fi button (wireless symbol) at the bottom of the screen to select the wireless network menu.

3. Enable Wi-Fi.

Make sure that Wi-Fi® is enabled. If it is not enabled, touch the *Wi-Fi* toggle to enable it.

4. Set up and manage a wireless network connection.

When Wi-Fi is enabled, the screen will show a list of available networks. Note: It may take a few moments for the list of wireless networks to appear.

Note: You must have your own wireless network and an 802.11b/g/n router with SSID broadcast enabled (hidden networks are not supported).

When a list of networks appears, touch the desired network. Note: You will need to know your network name (SSID). If your network has a password, you will also need to know the password.

Follow the prompts on the screen to enter your password and connect to the selected wireless network. (To use the keyboard, see HOW TO USE THE TOUCH SCREEN on page 18.)

When the console is connected to your wireless network, a checkmark will appear next to the wireless network name.

If you are having problems connecting to an encrypted network, make sure that your password is correct. Note: Passwords are case-sensitive.

Note: The console supports unsecured and secured (WEP, WPA™, and WPA2™) encryption. A broadband connection is recommended; performance depends on connection speed.

Note: If you have questions after following these instructions, go to support.iFit.com for assistance.

5. Exit the wireless network menu.

To exit the wireless network menu, touch the back button (arrow symbol).

HOW TO USE THE SOUND SYSTEM

To play music or audio books through the console sound system while you exercise, plug a 3.5 mm male to 3.5 mm male audio cable (not included) into the jack on the console and into a jack on your personal audio player; **make sure that the audio cable is fully plugged in. Note: To purchase an audio cable, see your local electronics store.**

Next, press the play button on your personal audio player. Adjust the volume level using the volume increase and decrease buttons or the volume control on your personal audio player.

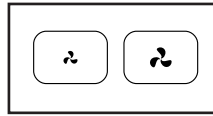

hold the Bluetooth button on the console for 3 seconds; the console will enter pairing mode.

When your device and the console pair successfully, the audio from your device will play through the console sound system.

The console can save 8 devices in its memory. If you have previously paired your device to the console, simply press the Bluetooth button to connect your device to the console.

You can erase devices from the console memory if necessary. To erase all the BLUETOOTH-enabled devices saved in the console memory, press and hold the Bluetooth button for 10 seconds.

HOW TO CONNECT TO THE SOUND SYSTEM WITH BLUETOOTH

If desired, you can connect your smart device to the console sound system with BLUETOOTH.

First, make sure that the BLUETOOTH option is enabled on your device.

Next, place or hold your device near the console. Then, pair your device to the console as follows: Press and

HOW TO CONNECT AN HDMI CABLE

To show your console screen on a TV or monitor, plug an HDMI cable (not included) into the port on the console and into a port on your TV or monitor; **make sure that the HDMI cable is fully plugged in. Note: To purchase an HDMI cable, see your local electronics store.**

FCC INFORMATION

This equipment has been tested and found to comply with the limits for a Class B digital device, pursuant to part 15 of the FCC Rules. These limits are designed to provide reasonable protection against harmful interference in a residential installation. This equipment generates, uses, and can radiate radio frequency energy and, if not installed and used in accordance with the instructions, may cause harmful interference to radio communications. However, there is no guarantee that interference will not occur in a particular installation. If this equipment does cause harmful interference to radio or television reception, which can be determined by turning the equipment off and on, try to correct the interference by one or more of the following measures:

- Reorient or relocate the receiving antenna.
- Increase the separation between the equipment and the receiver.
- Connect the equipment into an outlet on a circuit different from that to which the receiver is connected.
- Consult the dealer or an experienced radio/TV technician for help.

FCC CAUTION: To assure continued compliance, use only shielded interface cables when connecting to computer or peripheral devices. Changes or modifications not expressly approved by the party responsible for compliance could void the user's authority to operate this equipment.

IMPORTANT: To satisfy exposure compliance requirements, the antenna and transmitter in the console must be at least 8 in. (20 cm) from all persons and must not be near or connected to any other antenna or transmitter.

Note: The console contains FCC ID: SMFOMC360526A.

MAINTENANCE AND TROUBLESHOOTING

MAINTENANCE

Regular maintenance is important for optimal performance and to reduce wear. Inspect and properly tighten all parts each time the exercise bike is used. Replace any worn parts immediately.

To clean the exercise bike, use a damp cloth and a small amount of mild soap. **IMPORTANT: To avoid damage to the console, keep liquids away from the console and keep the console out of direct sunlight.**

CONSOLE TROUBLESHOOTING

If the console does not turn on, make sure that the power adapter is fully plugged in.

If the console does not display your heart rate when you use the handgrip heart rate monitor, see step 5 on page 20.

If the console does not display your heart rate when you use the chest heart rate monitor, see TROUBLESHOOTING on page 15.

If you are having problems connecting the console to a wireless network or if you are having problems with your iFit account or iFit workouts, go to support.iFit.com.

If a replacement power adapter is needed, call the telephone number on the cover of this manual. IMPORTANT: To avoid damaging the console, use only a manufacturer-supplied regulated power adapter.

TABLET HOLDER TROUBLESHOOTING

If the tablet holder does not stay in place, rotate the tablet holder backward and tighten the indicated screw (A) until the tablet holder stays in place when it is rotated to the desired position.

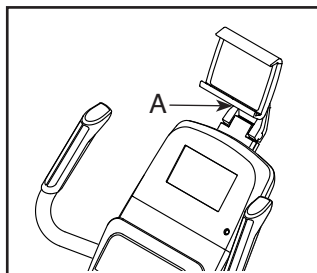

HOW TO ADJUST THE REED SWITCH

If the console does not display correct feedback, the reed switch should be adjusted. **Before adjusting the reed switch, first unplug the power adapter.**

Next, remove the Seat Post Knob (27), remove the Knob Shield (9), and slide the Shield Cover (7) upward.

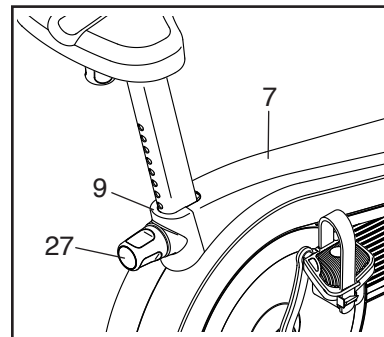

Next, remove all of the Screws (not shown) from the Right and Left Shields (10, 11).

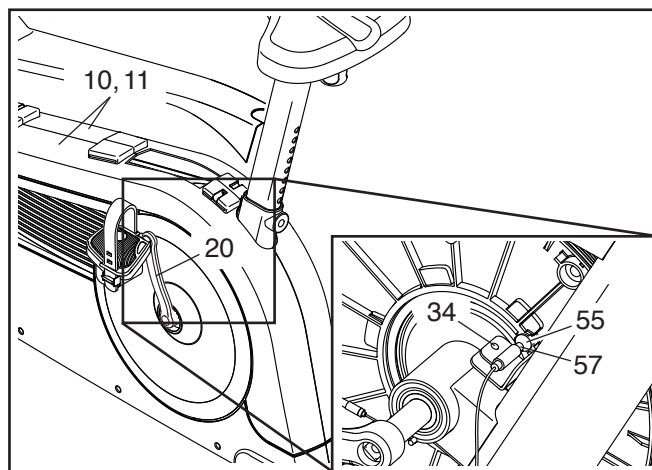

Then, carefully pull the tops of the Shields (10, 11) apart and locate the Reed Switch (57). Rotate the Left Crank Arm (20) until a Magnet (55) is aligned with the Reed Switch. Then, slightly loosen the #8 x 18mm Screw (34), slide the Reed Switch slightly toward or away from the Magnet, and then retighten the #8 x 18mm Screw.

Plug in the power adapter and rotate the Left Crank Arm (20) for a moment. Repeat these actions until the console displays correct feedback. When the reed switch is correctly adjusted, reattach the parts that you removed.

EXERCISE GUIDELINES

⚠️ WARNING: Before beginning this or any exercise program, consult your physician. This is especially important for persons over age 35 or persons with pre-existing health problems.

The heart rate monitor is not a medical device. Various factors may affect the accuracy of heart rate readings. The heart rate monitor is intended only as an exercise aid in determining heart rate trends in general.

These guidelines will help you to plan your exercise program. For detailed exercise information, obtain a reputable book or consult your physician. Remember, proper nutrition and adequate rest are essential for successful results.

EXERCISE INTENSITY

Whether your goal is to burn fat or to strengthen your cardiovascular system, exercising at the proper intensity is the key to achieving results. You can use your heart rate as a guide to find the proper intensity level. The chart below shows recommended heart rates for fat burning and aerobic exercise.

165	155	145	140	130	125	115	❤️
145	138	130	125	118	110	103	❤️
125	120	115	110	105	95	90	❤️
<hr/>							
20	30	40	50	60	70	80	

To find the proper intensity level, find your age at the bottom of the chart (ages are rounded off to the nearest ten years). The three numbers listed above your age define your “training zone.” The lowest number is the heart rate for fat burning, the middle number is the heart rate for maximum fat burning, and the highest number is the heart rate for aerobic exercise.

Burning Fat—To burn fat effectively, you must exercise at a low intensity level for a sustained period of time. During the first few minutes of exercise, your body uses carbohydrate calories for energy. Only after the first few minutes of exercise does your body begin to use stored fat calories for energy. If your goal is to burn fat, adjust the intensity of your exercise until your heart rate is near the lowest number in your training zone. For maximum fat burning, exercise with your heart rate near the middle number in your training zone.

Aerobic Exercise—If your goal is to strengthen your cardiovascular system, you must perform aerobic exercise, which is activity that requires large amounts of oxygen for prolonged periods of time. For aerobic exercise, adjust the intensity of your exercise until your heart rate is near the highest number in your training zone.

WORKOUT GUIDELINES

Warming Up—Start with 5 to 10 minutes of stretching and light exercise. A warm-up increases your body temperature, heart rate, and circulation in preparation for exercise.

Training Zone Exercise—Exercise for 20 to 30 minutes with your heart rate in your training zone. (During the first few weeks of your exercise program, do not keep your heart rate in your training zone for longer than 20 minutes.) Breathe regularly and deeply as you exercise; never hold your breath.

Cooling Down—Finish with 5 to 10 minutes of stretching. Stretching increases the flexibility of your muscles and helps to prevent post-exercise problems.

EXERCISE FREQUENCY

To maintain or improve your condition, complete three workouts each week, with at least one day of rest between workouts. After a few months of regular exercise, you may complete up to five workouts each week, if desired. Remember, the key to success is to make exercise a regular and enjoyable part of your everyday life.

PART LIST

Model No. NTEX76918.0 R0118A

Key No.	Qty.	Description	Key No.	Qty.	Description
1	1	Frame	37	2	Handgrip
2	1	Front Stabilizer	38	1	Pulley
3	1	Rear Stabilizer	39	1	Crank
4	1	Upright	40	2	Crank Bearing
5	1	Right Handlebar	41	2	Snap Ring
6	1	Seat Post	42	1	Eddy Mechanism
7	1	Shield Cover	43	8	M8 Locknut
8	1	Accessory Tray	44	4	M8 x 18mm Bolt
9	1	Knob Shield	45	1	Idler
10	1	Right Shield	46	1	Chest Heart Rate Monitor
11	1	Left Shield	47	1	Resistance Motor
12	1	Front Console Cover	48	1	M10 x 65mm Hex Screw
13	1	Console	49	1	M6 x 20mm Hex Screw
14	1	Left Handlebar	50	1	M6 Washer
15	1	Rear Console Cover	51	1	M6 x 20mm Screw
16	1	Tablet Holder	52	4	#10 x 15mm Screw
17	2	Wheel	53	4	M10 x 110mm Screw
18	2	M10 x 62mm Bolt	54	1	Drive Belt
19	1	Right Crank Arm	55	2	Magnet
20	1	Left Crank Arm	56	1	Clamp
21	1	Right Pedal/Strap	57	1	Reed Switch/Wire
22	1	Left Pedal/Strap	58	1	Main Wire
23	1	Seat	59	3	Tree Fastener
24	1	Seat Carriage	60	2	M10 Flange Nut
25	2	Mechanism Spacer	61	2	Pulse Wire
26	1	Seat Knob	62	2	M8 Flange Screw
27	1	Seat Post Knob	63	4	M8 x 16mm Screw
28	1	Seat Post Sleeve	64	4	M8 Washer
29	1	Power Receptacle/Wire	65	4	M10 x 15mm Screw
30	1	Seat Bracket	66	2	M10 Jam Nut
31	4	M10 Washer	67	1	Power Adapter
32	2	Rear Stabilizer Cap	68	2	Crank Cap
33	2	Front Stabilizer Cap	69	4	Tablet Holder Screw
34	27	#8 x 18mm Screw	*	–	User's Manual
35	1	M8 x 28mm Hex Screw	*	–	Assembly Tool
36	2	Leveling Foot			

Note: Specifications are subject to change without notice. See the back cover of this manual for information about ordering replacement parts. *These parts are not illustrated.

EXPLODED DRAWING

Model No. NTEX76918.0 R0118A

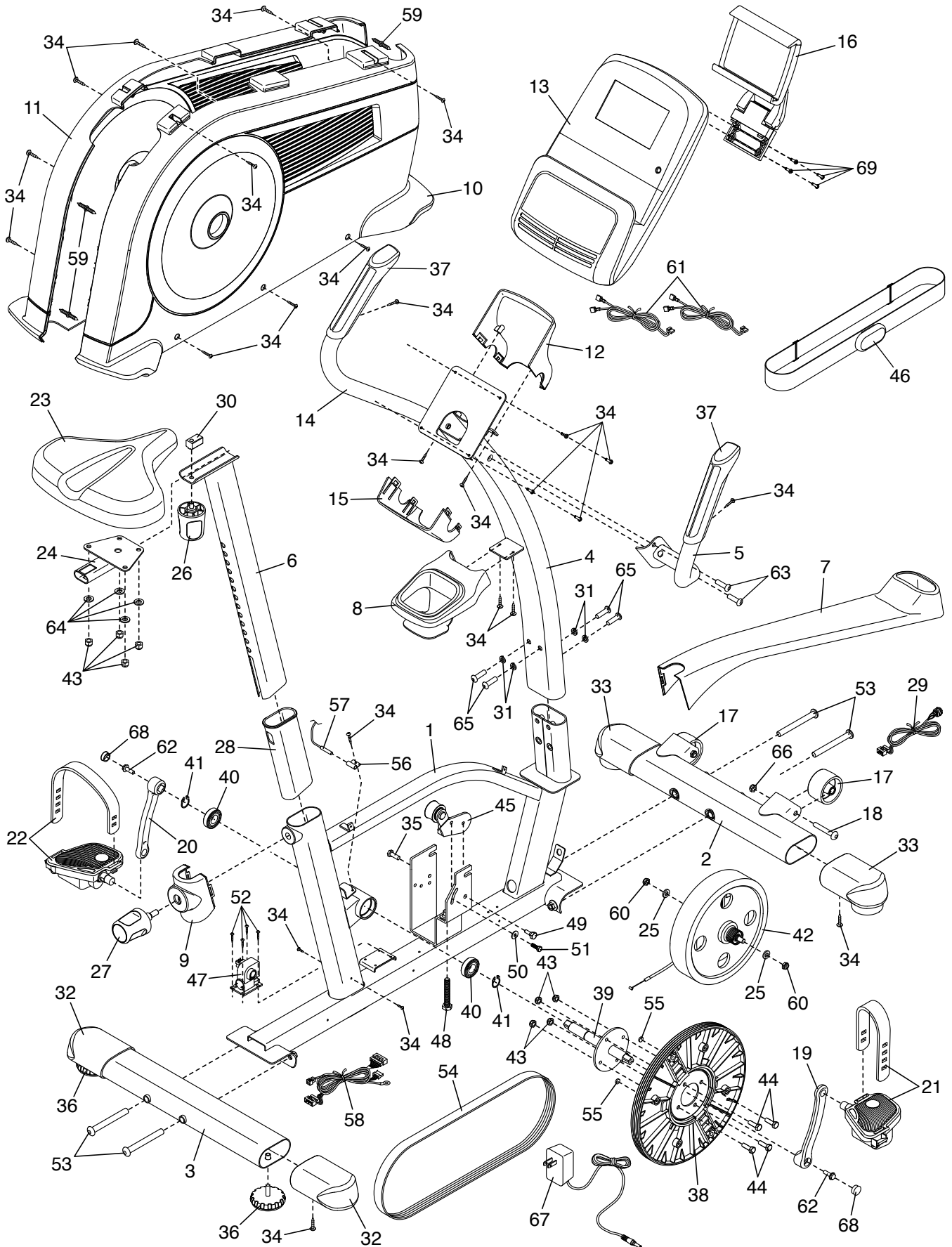

ORDERING REPLACEMENT PARTS

To order replacement parts, please see the front cover of this manual. To help us assist you, be prepared to provide the following information when contacting us:

- the model number and serial number of the product (see the front cover of this manual)
- the name of the product (see the front cover of this manual)
- the key number and description of the replacement part(s) (see the PART LIST and the EXPLODED DRAWING near the end of this manual)

LIMITED WARRANTY

IMPORTANT: To protect your fitness equipment with an extended service plan, see page 4.

ICON Health & Fitness, Inc. (ICON) warrants this product to be free from defects in workmanship and material, under normal use and service conditions. The frame is warranted for the lifetime of the original purchaser (customer). Parts are warranted for three (3) years from the date of purchase. Labor is warranted for one (1) year from the date of purchase.

This warranty extends only to the original purchaser (customer) and is not transferrable. ICON's obligation under this warranty is limited to repairing or replacing, at ICON's option, the product through one of its authorized service providers. All repairs for which warranty claims are made must be preauthorized by ICON. If replacement parts are shipped while the product is under warranty, the customer will be responsible for a minimal handling charge. For in-home service, the customer may be responsible for a minimal trip charge. This warranty does not extend to freight damage to the product. This warranty will automatically be voided by the following conditions: (1) if the product is used as a store display model, (2) if the product is purchased or transported outside the USA, (3) if all instructions and warnings in this manual are not followed, (4) if the product is abused or improperly or abnormally used, or (5) if the product is used for commercial or rental purposes. No other warranty beyond that specifically set forth above is authorized by ICON.

ICON is not responsible or liable for the following damages: (1) indirect, special, or consequential damages arising out of or in connection with the use or performance of the product; (2) damages with respect to any economic loss, loss of property, loss of revenues or profits, loss of enjoyment or use, or costs of removal or installation; or (3) other consequential damages of any kind. Some states do not allow the exclusion or limitation of incidental or consequential damages. Accordingly, the above limitation may not apply to the customer.

The warranty extended hereunder is in lieu of any and all other warranties, and any implied warranties of merchantability or fitness for a particular purpose are limited in their scope and duration to the terms set forth herein. Some states do not allow limitations on how long an implied warranty lasts. Accordingly, the above limitation may not apply to the customer. This warranty provides specific legal rights; the customer may have other rights that vary from state to state.

For warranty service, please call the telephone number on the front cover of this manual. Please be prepared to provide the model number and serial number of the product (see the front cover of this manual).

ICON Health & Fitness, Inc., 1500 S. 1000 W., Logan, UT 84321-9813