

SPIRIT II

E-210 LP • S-210 LP • E-310 LP • S-310 LP
E-210 NG • S-210 NG • E-310 NG • S-310 NG

ASSEMBLY GUIDE

GUÍA DE MONTAJE | ENSEMBLE GUIDE

Before you begin

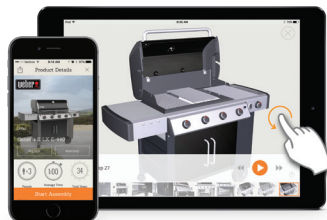

Enhance your assembly experience.

Download the free BILT™ app for
3D step-by-step instructions.



Descarga gratis la app BILT™ y sigue las instrucciones 3D paso a paso.
Téléchargez gratuitement l'application BILT™ pour obtenir les instructions étape par étape en 3D.

59503

07/21/17
enUS / esMX / frCA



FOR LIFE!

- EN**
- △ Assemble grill on a flat, level, and soft surface.
 - △ Remove protective film from stainless steel parts before installing.
 - △ Do not use power tools for assembly.
 - △ Two people required for assembly.
 - △ There may be visual differences between illustrations and model purchased.
 - △ All packing material is recyclable.
-

- ES**
- △ Monte el asador sobre una superficie llana, nivelada y lisa.
 - △ Retire la película protectora de las piezas de acero inoxidable antes de llevar a cabo la instalación.
 - △ No use herramientas eléctricas para montar el asador.
 - △ Se requieren dos personas para montar el asador.
 - △ Puede que existan diferencias visuales entre las ilustraciones y el modelo adquirido.
 - △ Todos los materiales del embalaje son reciclables.
-

- FR**
- △ Assemblez le barbecue sur une surface plate, de niveau et souple.
 - △ Avant de procéder à l'assemblage, retirez le film protecteur qui recouvre les pièces en acier inoxydable.
 - △ N'utilisez pas d'outil électrique pour assembler le barbecue.
 - △ Il faut deux personnes pour assembler le barbecue.
 - △ Le modèle de barbecue que vous avez acheté peut différer des illustrations.
 - △ L'emballage est entièrement recyclable.

TOOLS REQUIRED:
HERRAMIENTAS NECESARIAS:
OUTILS NÉCESSAIRES:

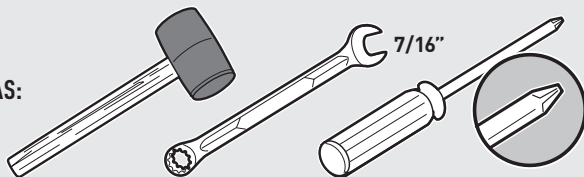

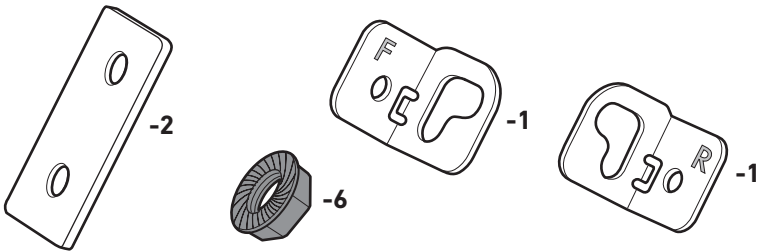
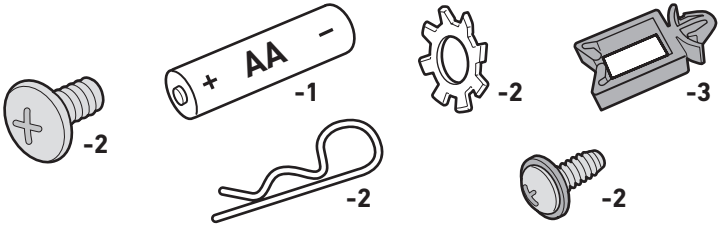
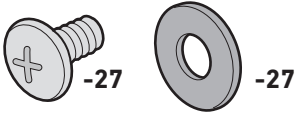

210

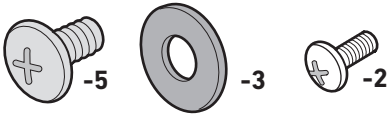

310



LP

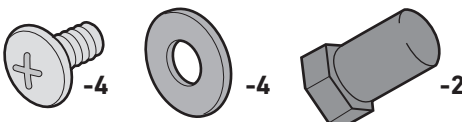

- For Liquid Propane gas grills only.
- Sólo para barbacoas de gas propano líquido.
- Uniquement compatible avec les barbecues à gaz propane.

1

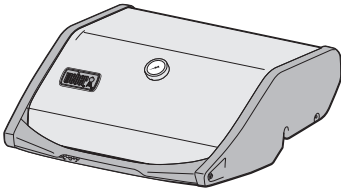

1

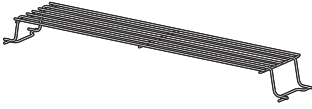

2

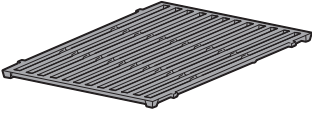

1

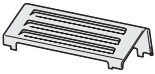

1

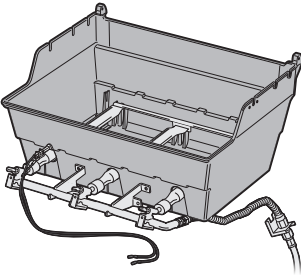

1

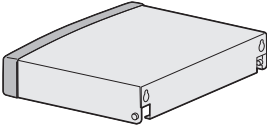

1

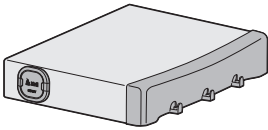

1

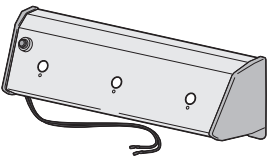

1

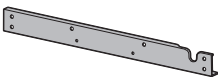

1

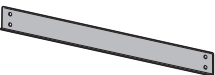

1

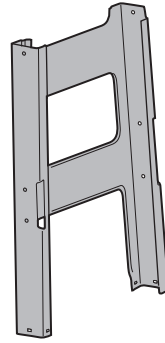

1

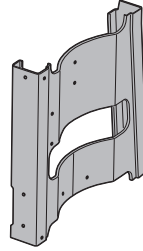

1

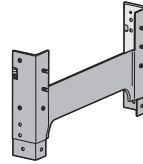

1

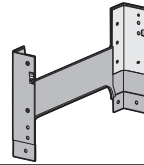

1

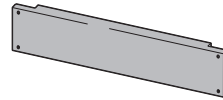

1

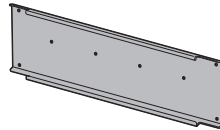

1



1

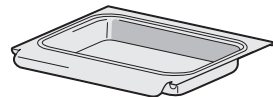

1

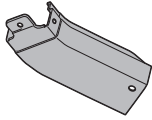

1

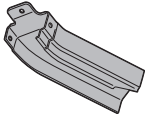

1



2

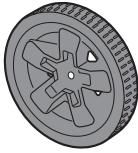

2



1

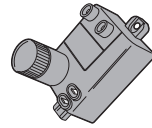

1

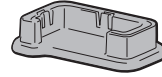

1

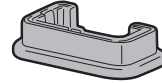

210

3

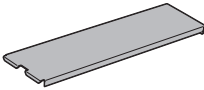

2



3

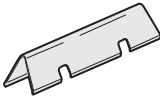

310

4

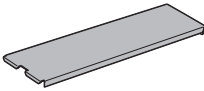

3



5

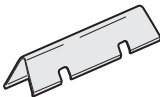

LP

1

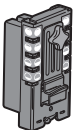

- For Liquid Propane gas grills only.
- Sólo para barbacoas de gas propano líquido.
- Uniquement compatible avec les barbecues à gaz propane.

1



- Download the free BILT app for 3D step-by-step instructions.
- Descarga gratis la app BILT™ y sigue las instrucciones 3D paso a paso.
- Téléchargez gratuitement l'application BILT™ pour obtenir les instructions étape par étape en 3D.

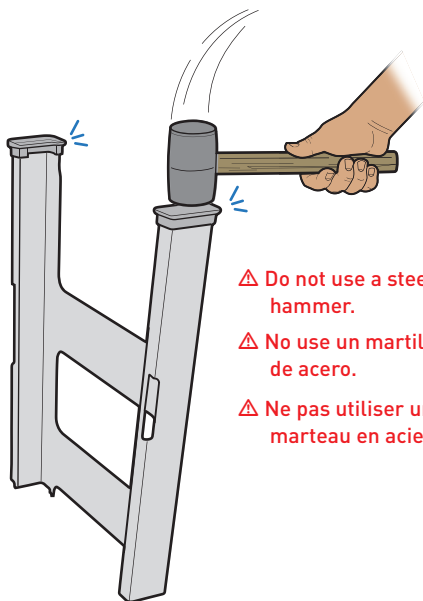
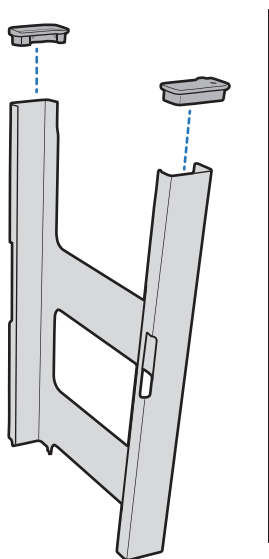

2

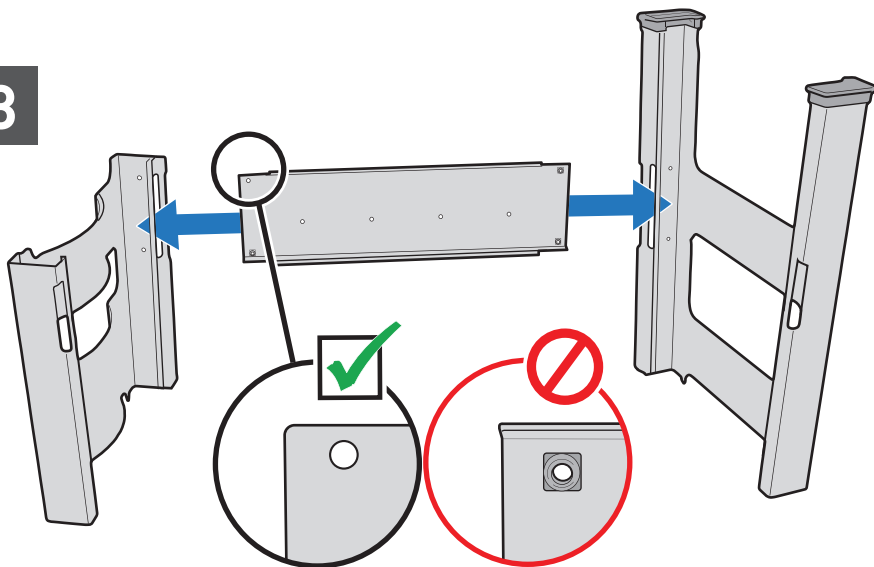

- ⚠ Do not use a steel hammer.
- ⚠ No use un martillo de acero.
- ⚠ Ne pas utiliser un marteau en acier.

3

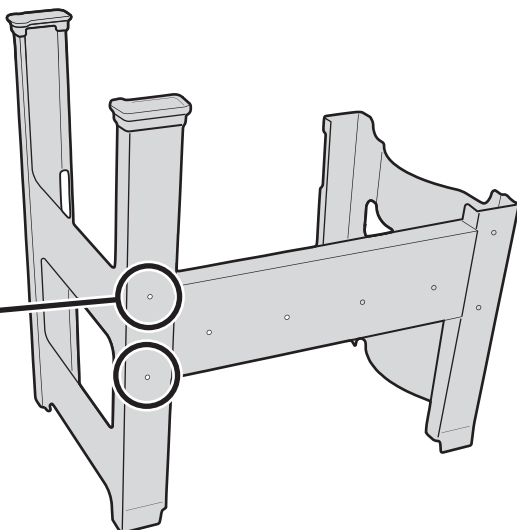
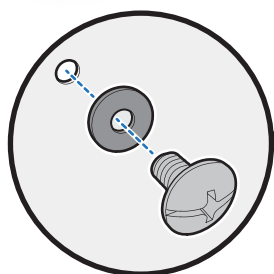
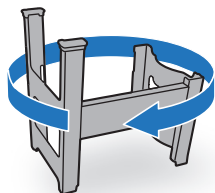
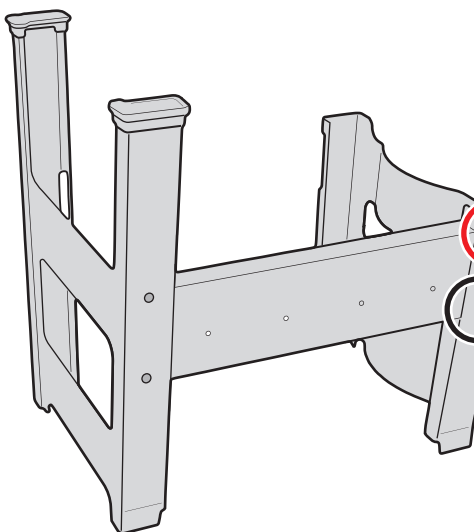

42- 2- **5**1- 1- 

△ NO screw and washer.
 △ NO INSTALE el tornillo con la arandela en este orificio.
 △ Ne contient AUCUNE vis ou rondelle.

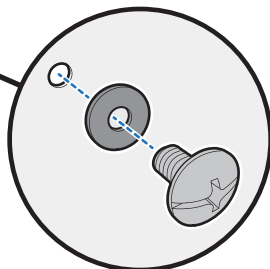

6

3- 

3- 

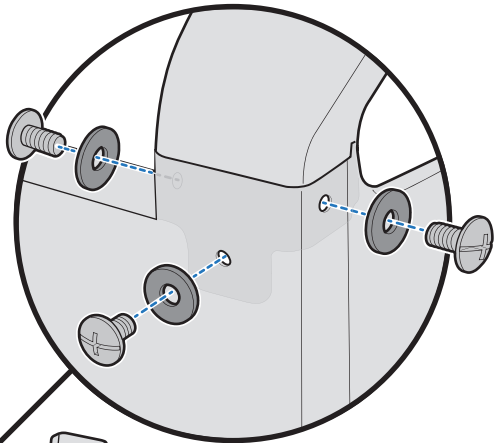
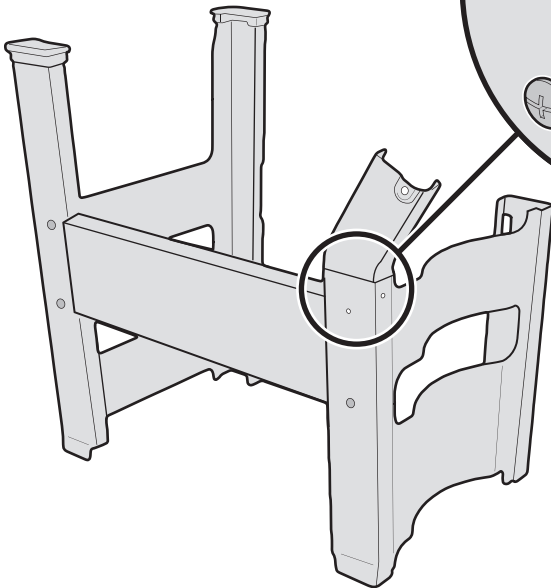
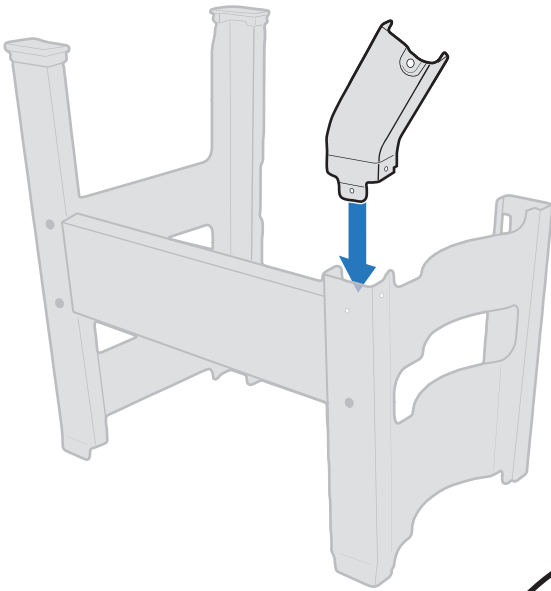

7

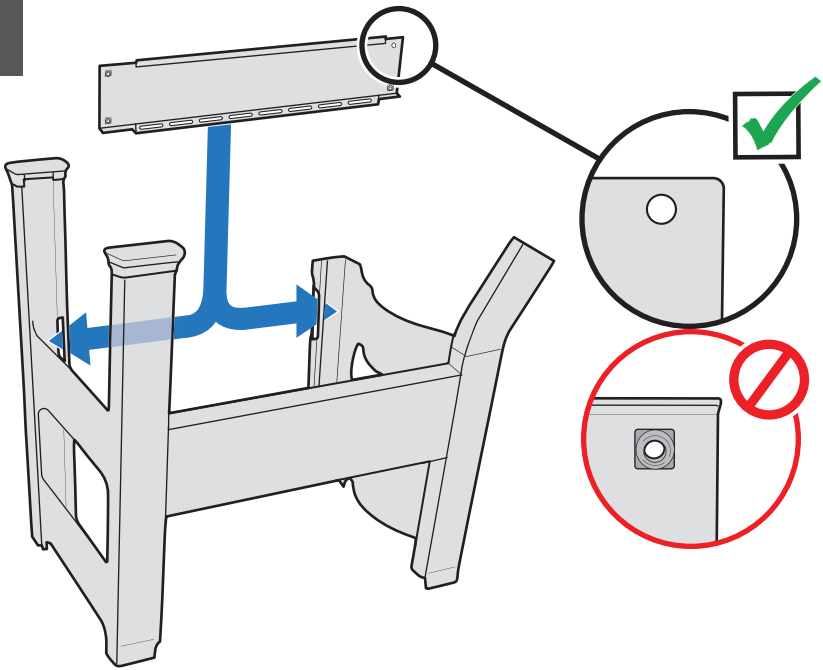

8

2- 

2- 

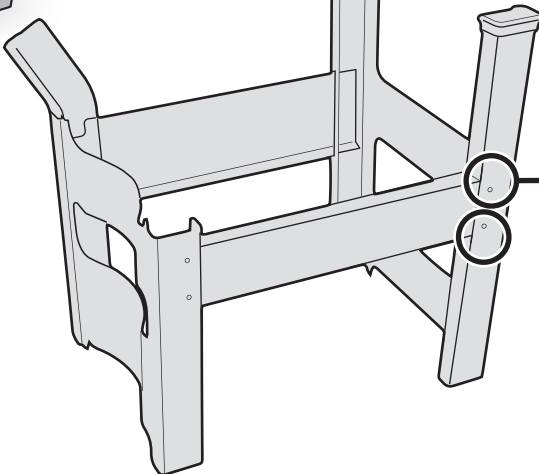
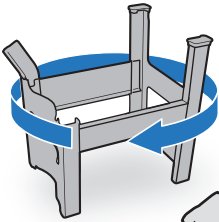

9

1-



1-



⚠ NO screw and washer.

⚠ NO INSTALE el tornillo con la arandela en este orificio.

⚠ Ne contient AUCUNE vis ou rondelle.

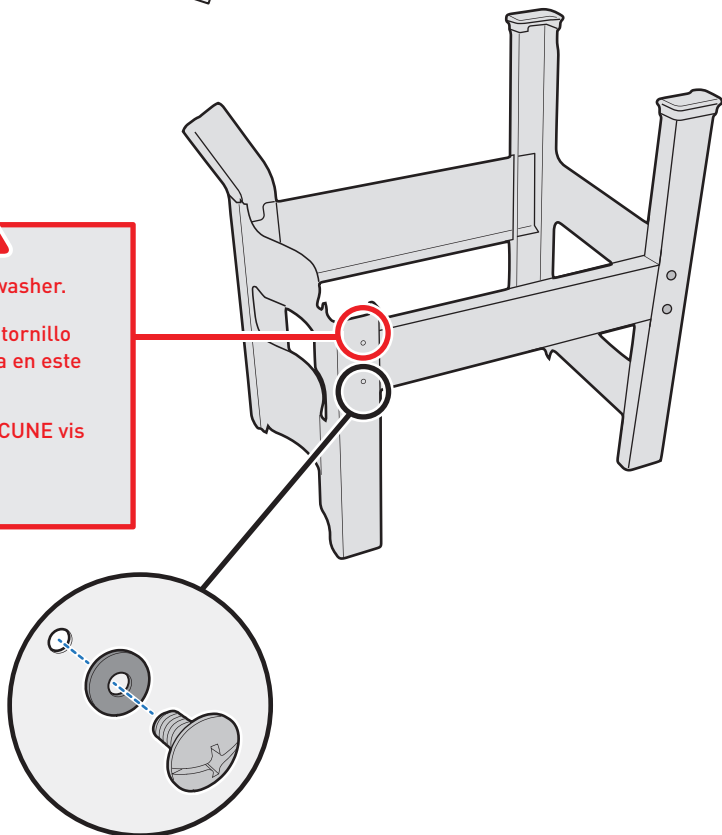

10

3- 

3- 

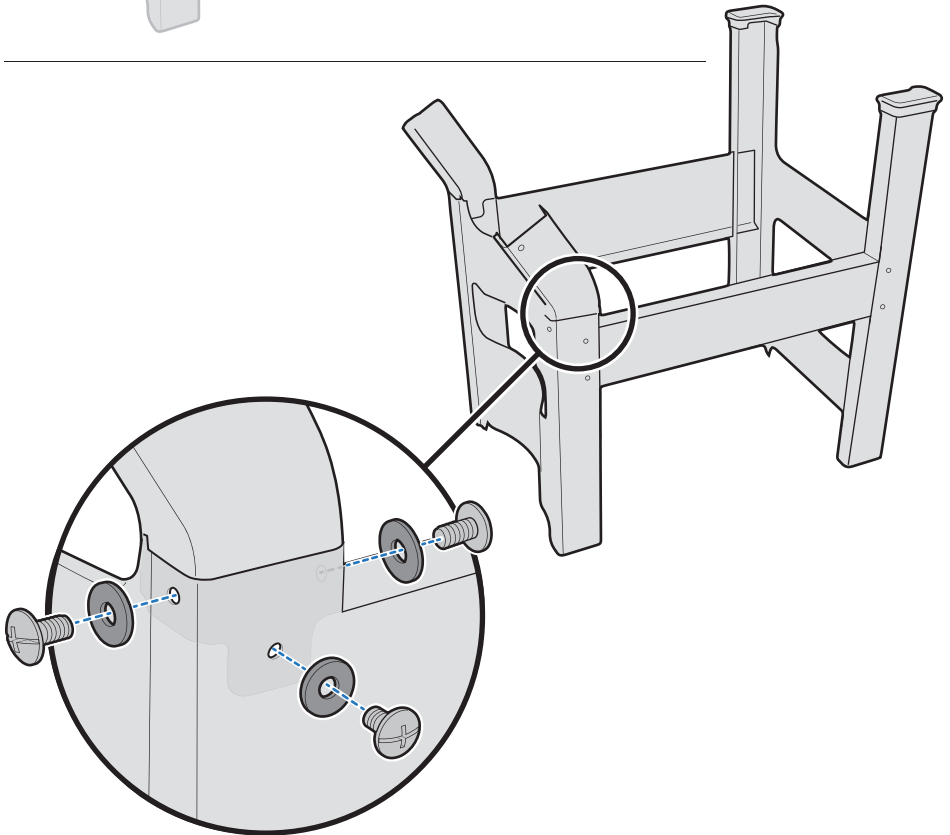
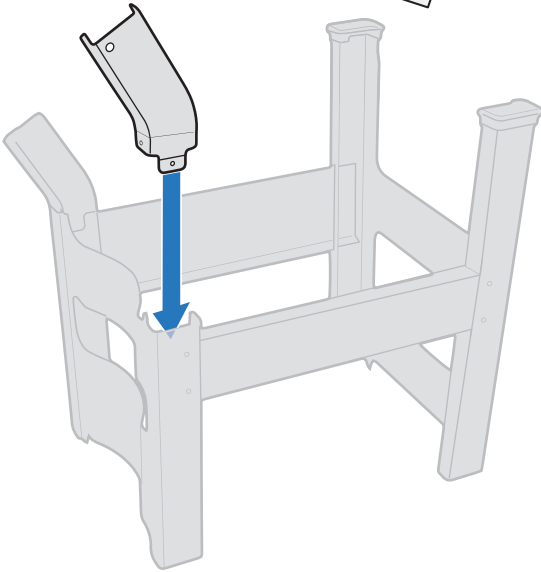

11

1-

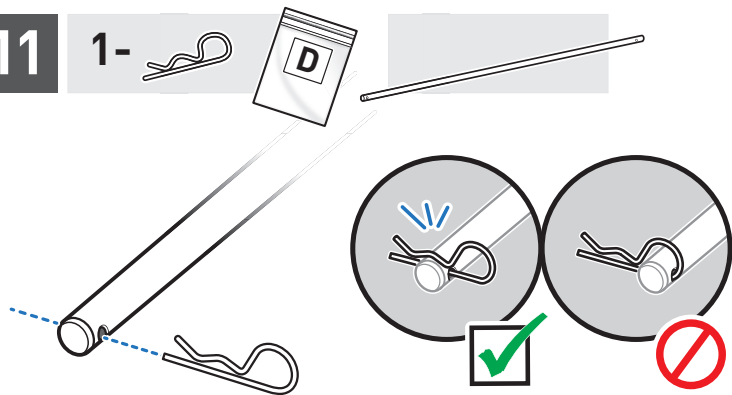

12

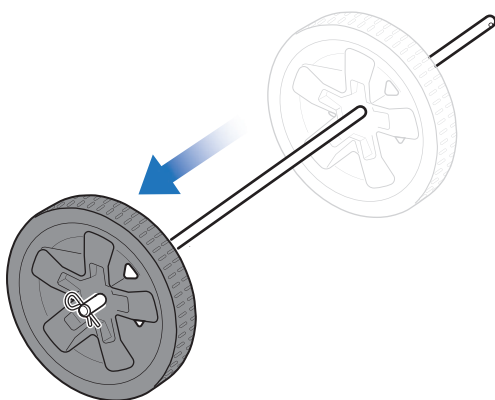

13

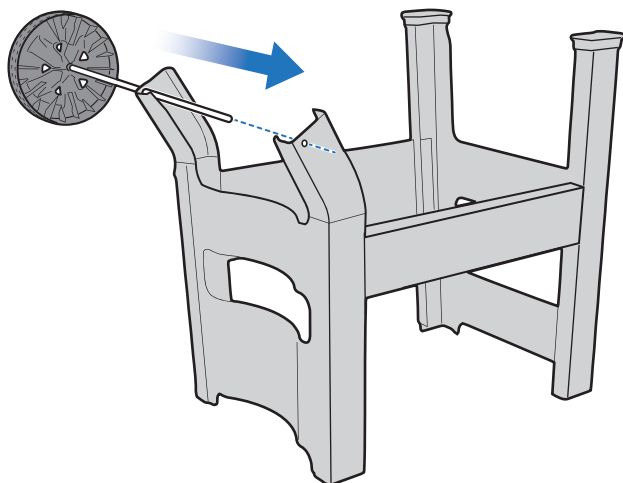

14

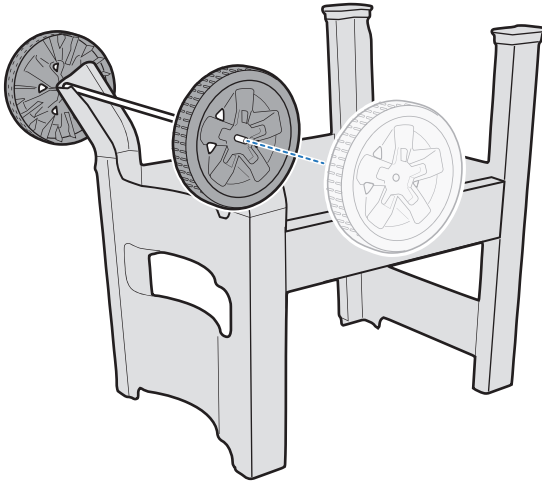

15

1-

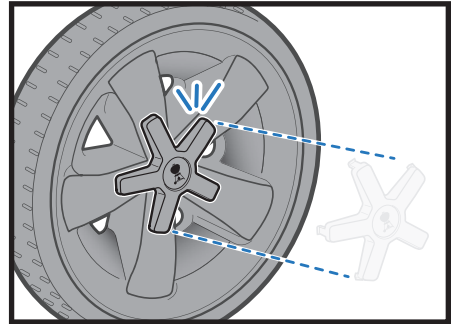
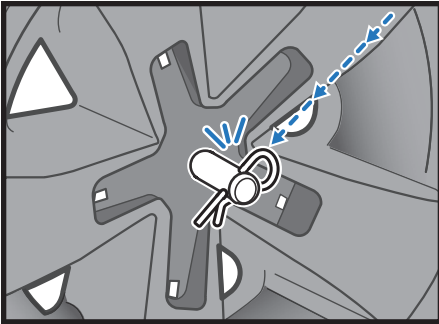
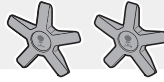

16

210

3-

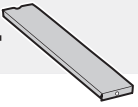

310

4-

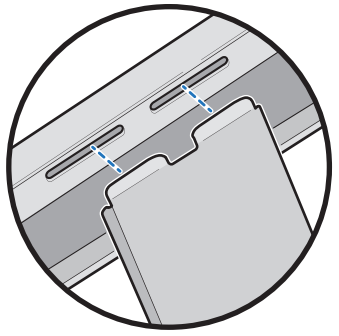
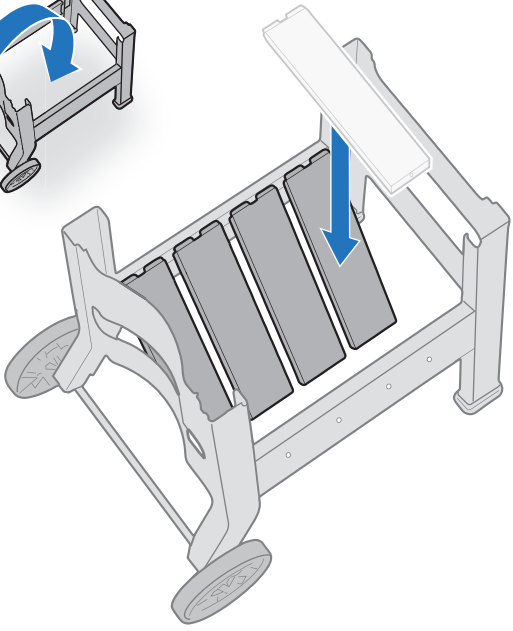
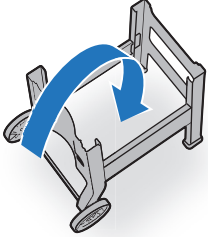
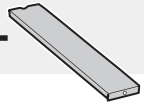

17

210

3-



3-



310

4-



4-

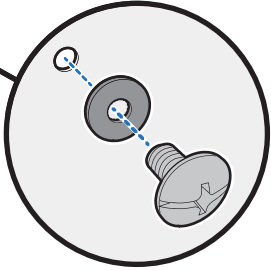
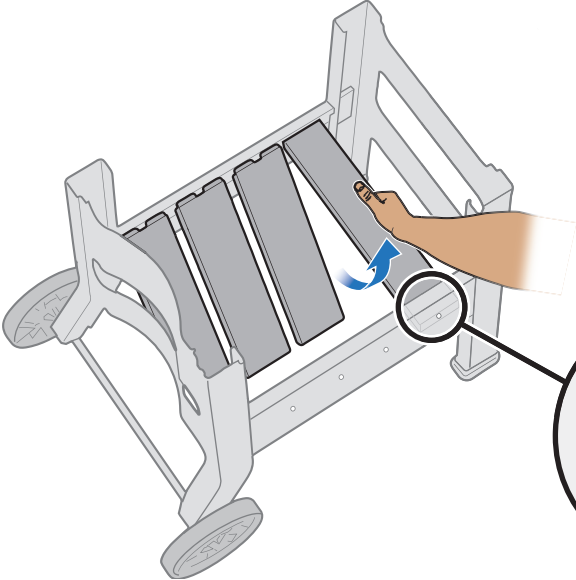

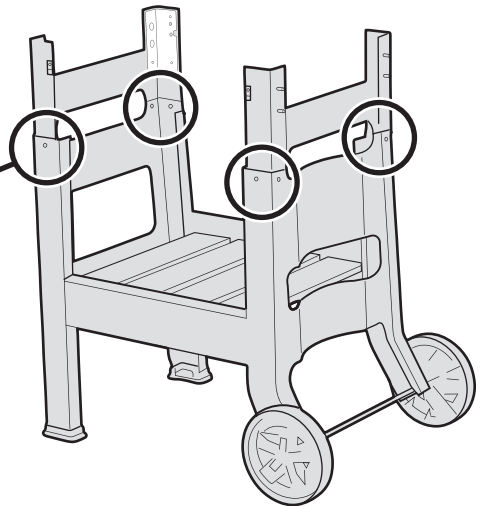
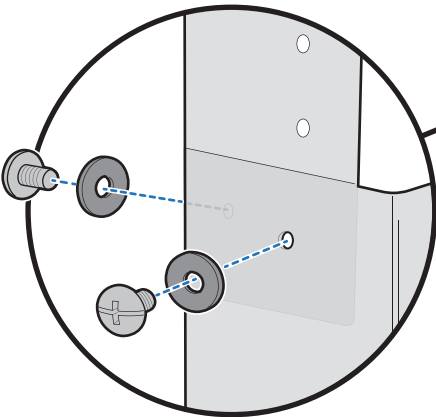
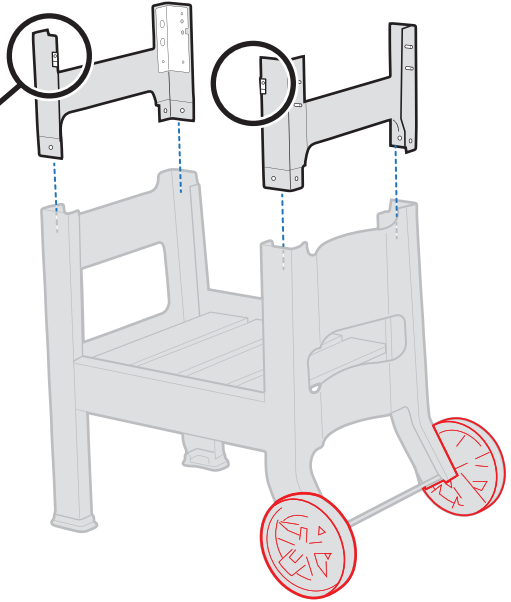
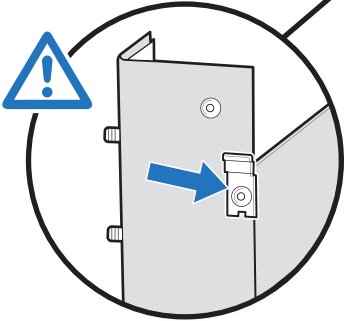
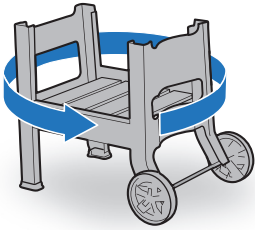
188- 8- **△ Wheels must be to the RIGHT.****△ Las ruedas deben quedar a la DERECHA.****△ Les roues doivent être à DROITE.**

19

2- 

2- 

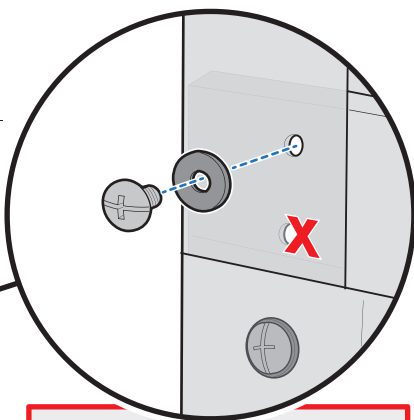
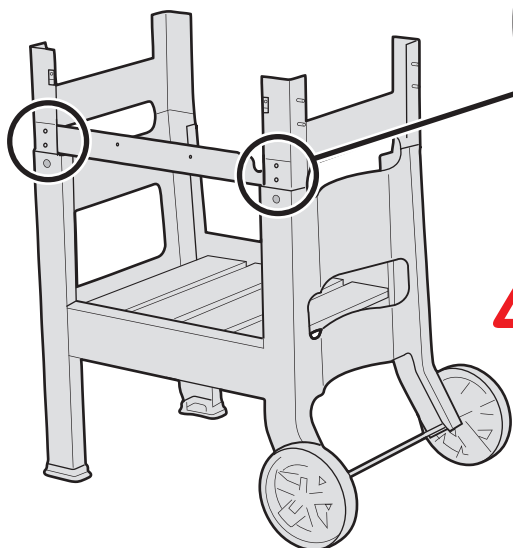
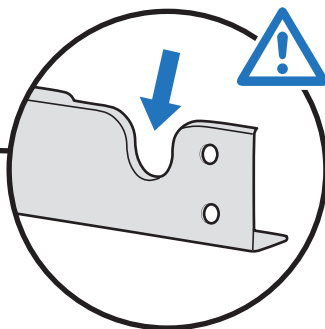
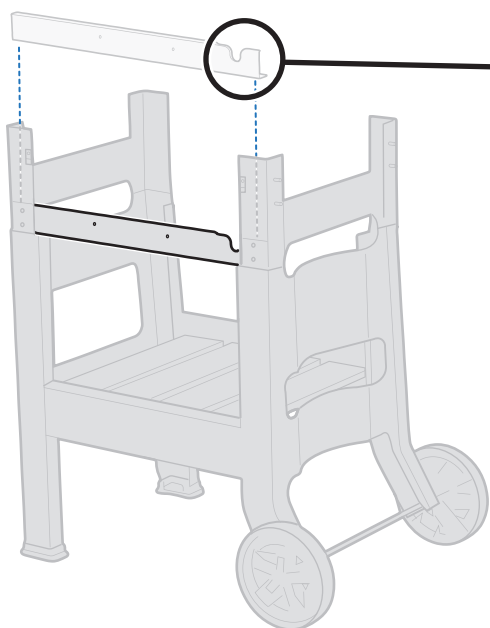

⚠ Install top screw and washer **ONLY**.

⚠ Instale un tornillo con una arandela **SÓLO** en el orificio superior.

⚠ Installer **UNIQUEMENT** la vis et la rondelle du haut.

20

4- 

4- 

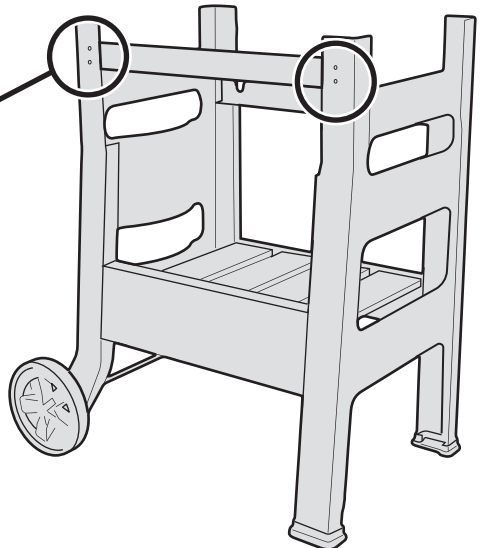
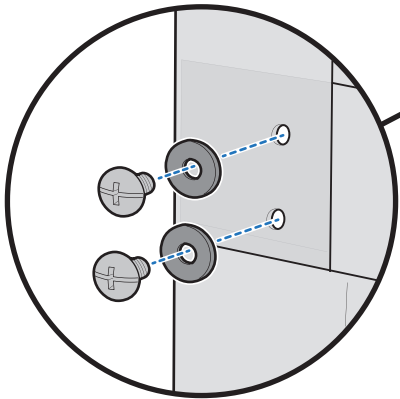
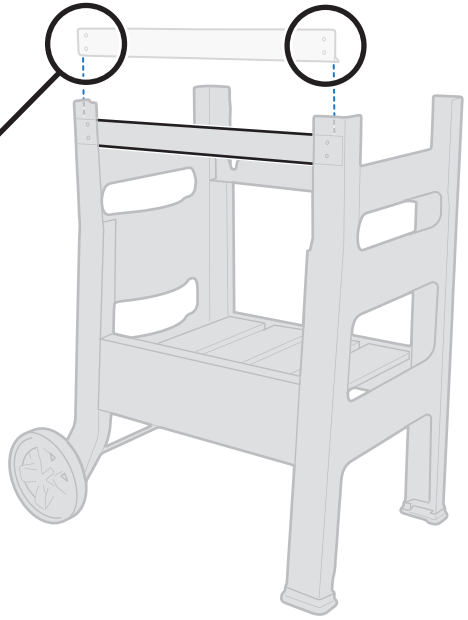
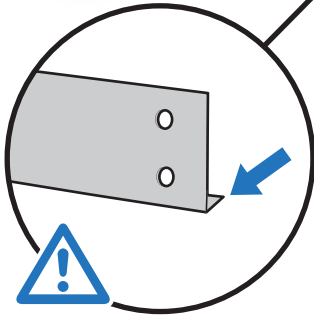
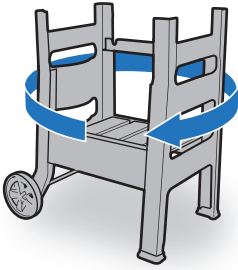

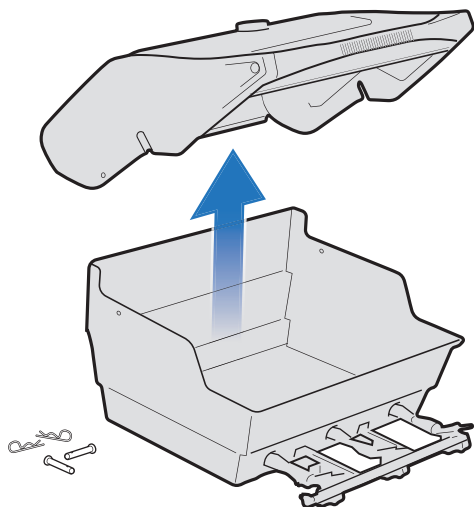
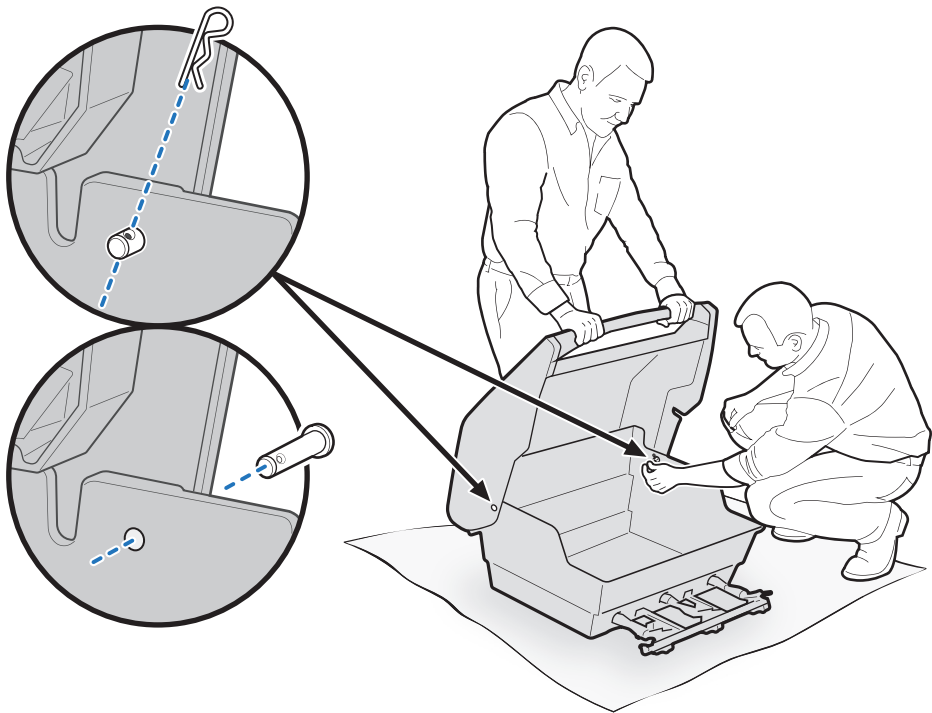

22

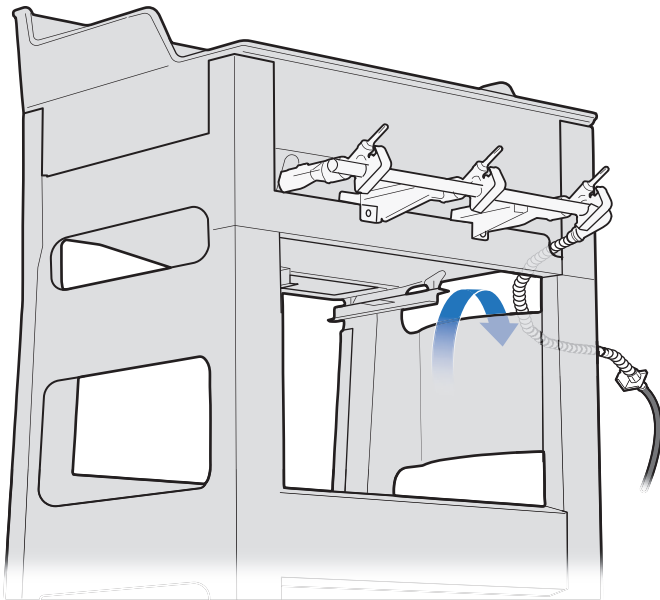
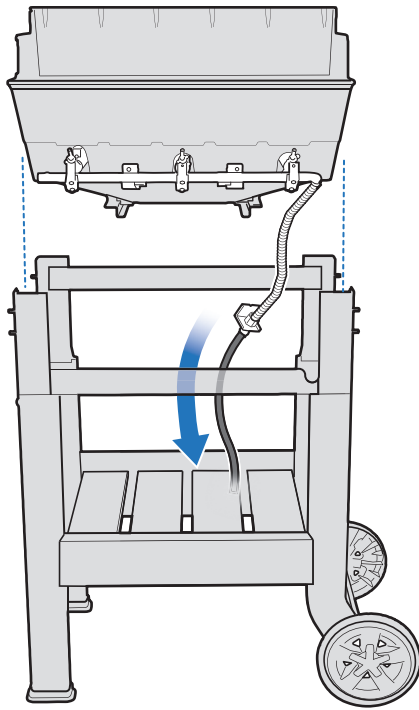
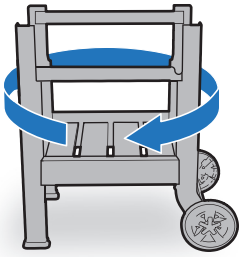

23

1- 

1- 

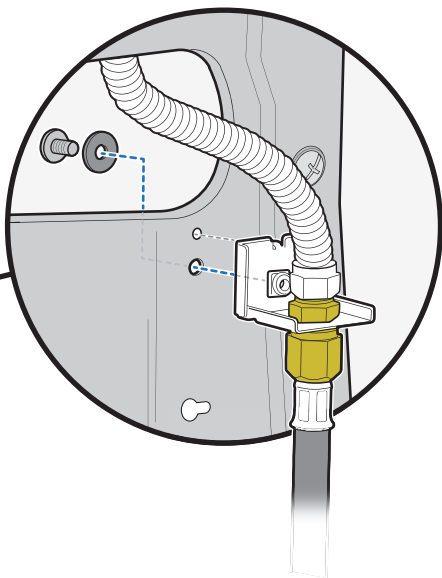
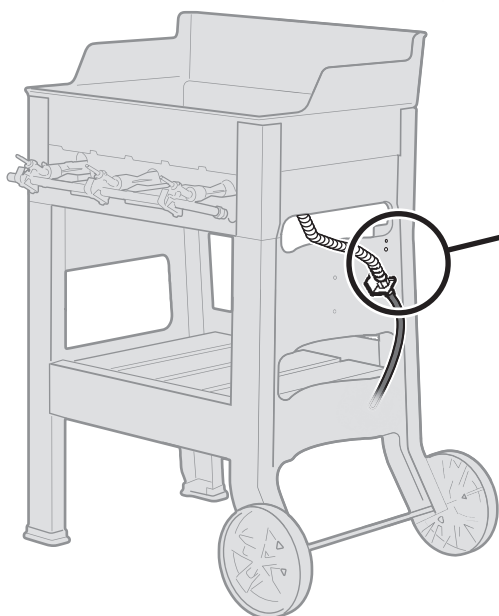

24

2- 

2- 

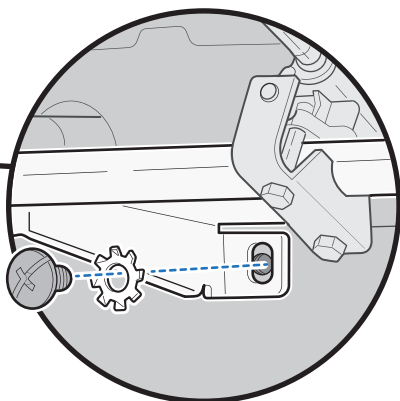
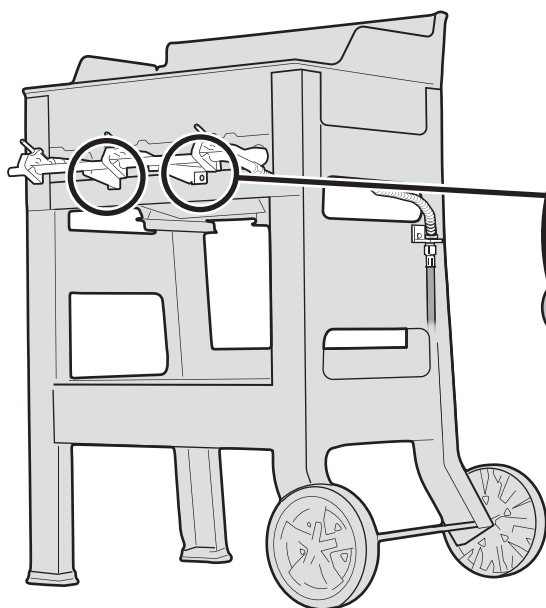

25

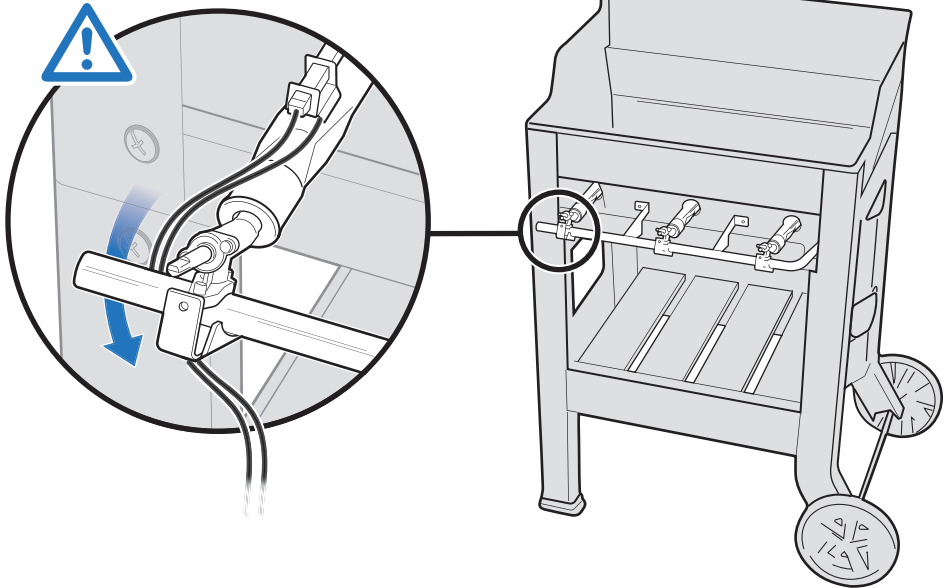

26

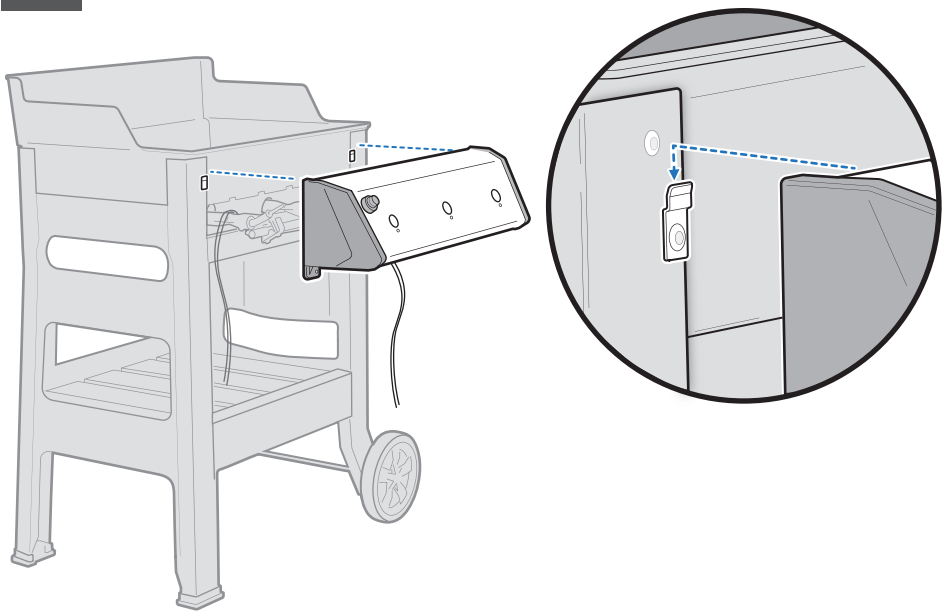

27

210

2-



2-



310

2-



3-

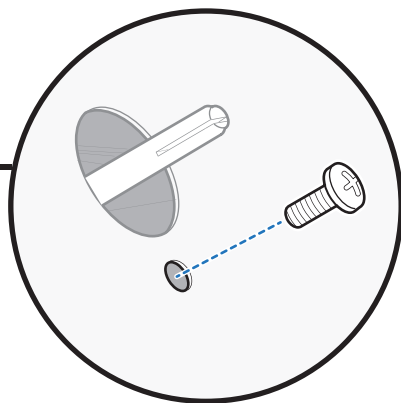
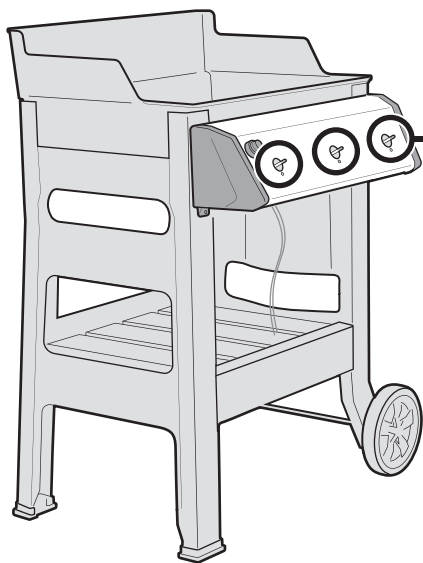
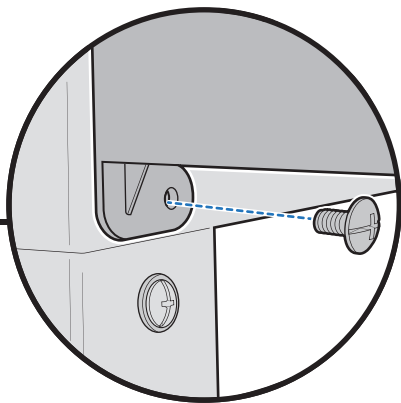
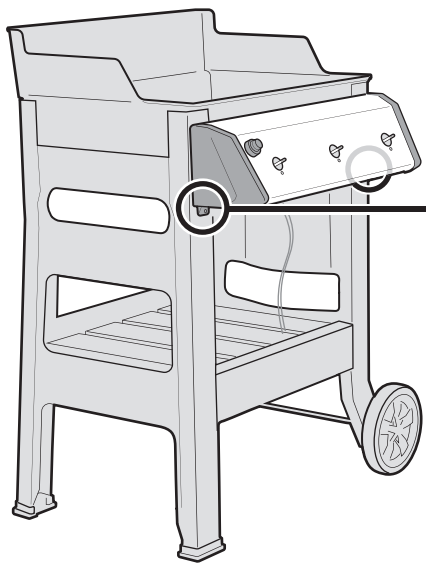

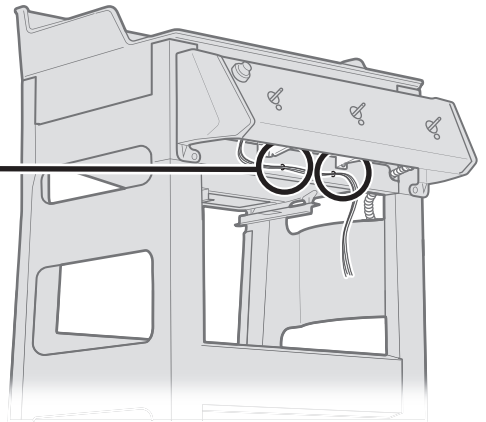
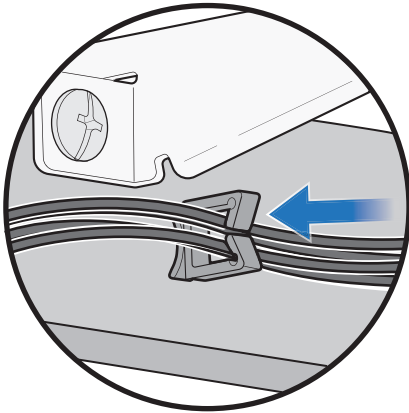
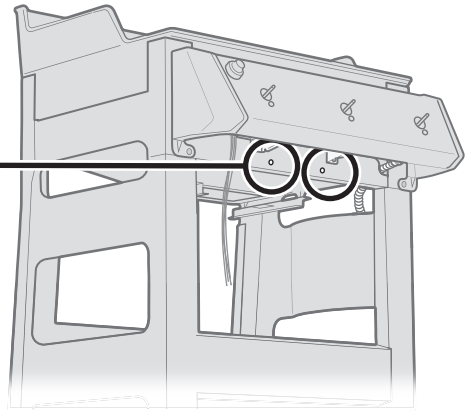
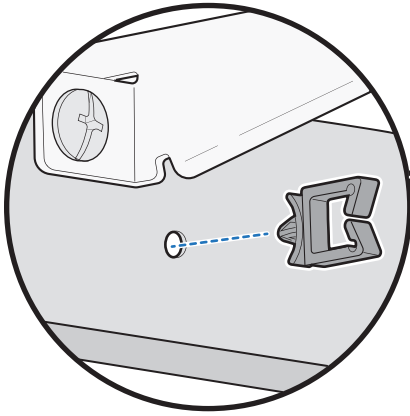

29



⚠ Wires must be routed **AROUND** and **BEHIND** the steel gas line.

⚠ Los cables deben pasarse **ALREDEDOR** del tubo de gas de acero y **POR DETRÁS** del mismo.

⚠ Les câbles doivent passer **AUTOUR** et **DERRIÈRE** la conduite de gaz en acier.

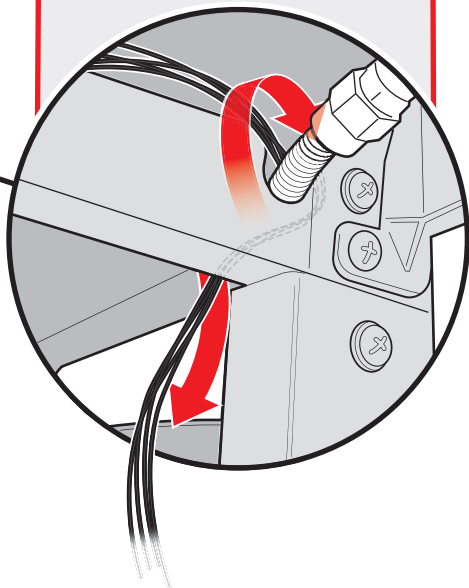
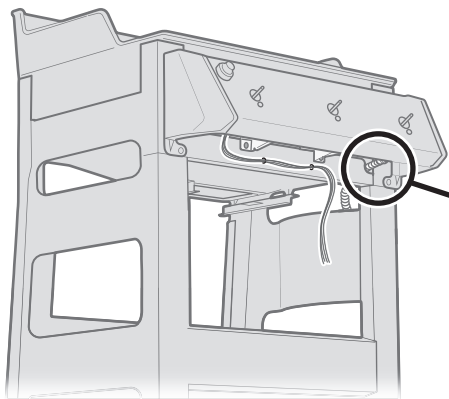

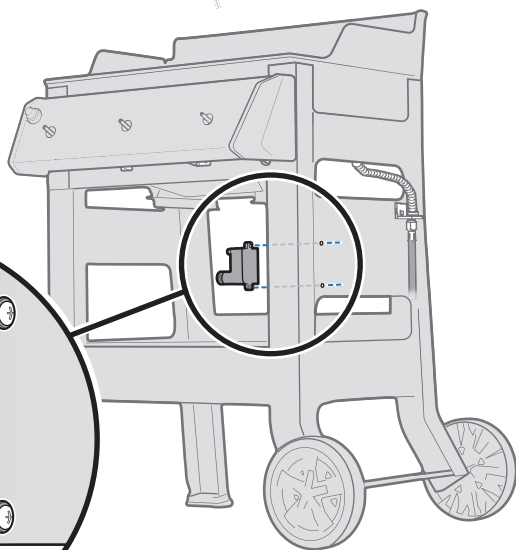
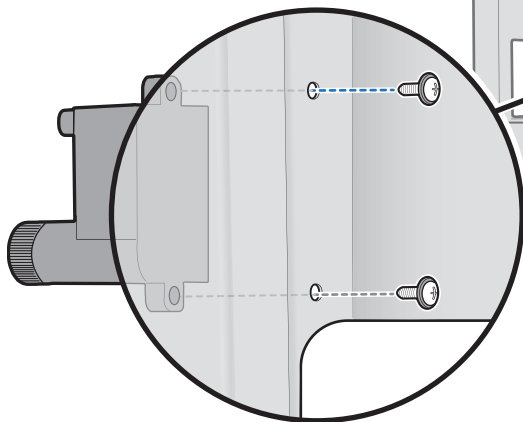

30

2-

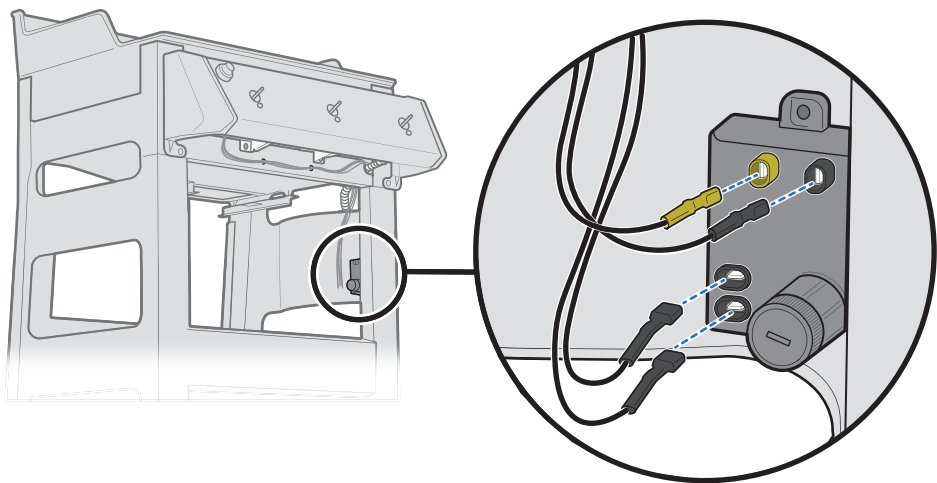

31



32 1- 

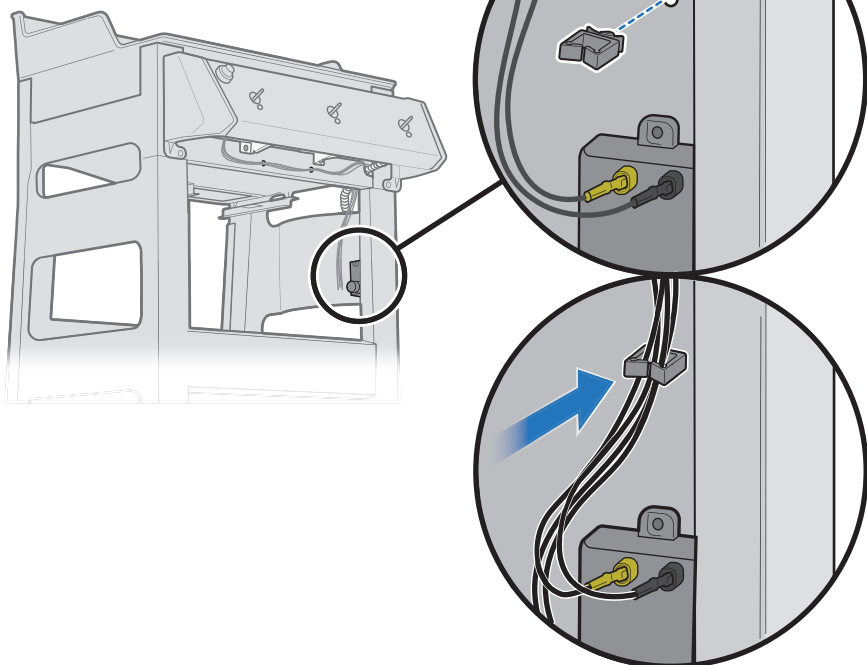

33

1-

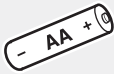

D

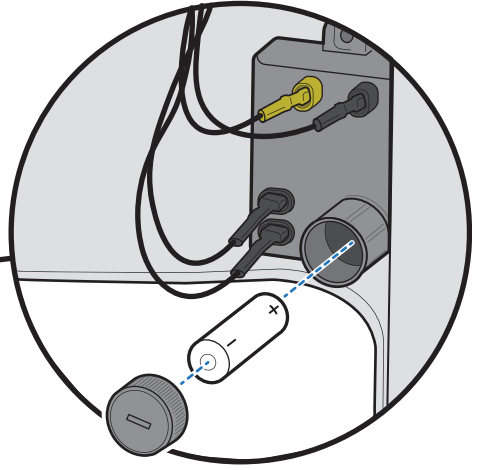
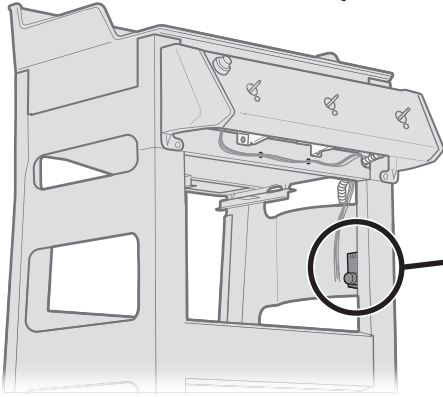

34

4-



2-



E

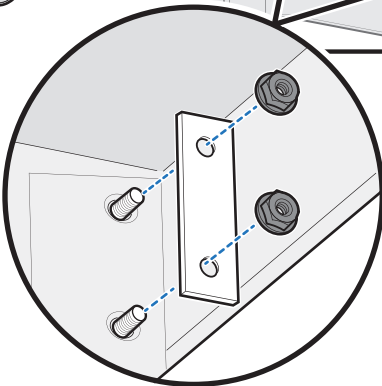
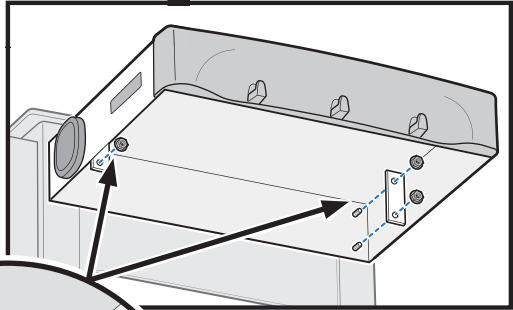
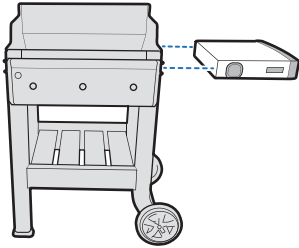

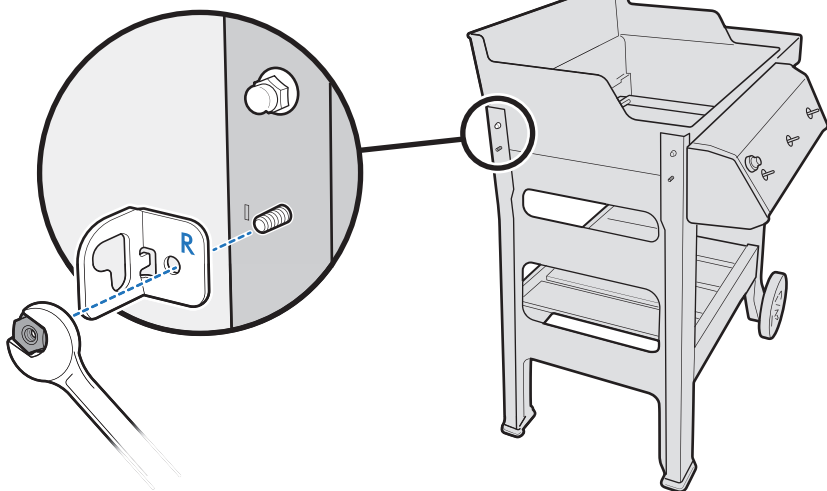
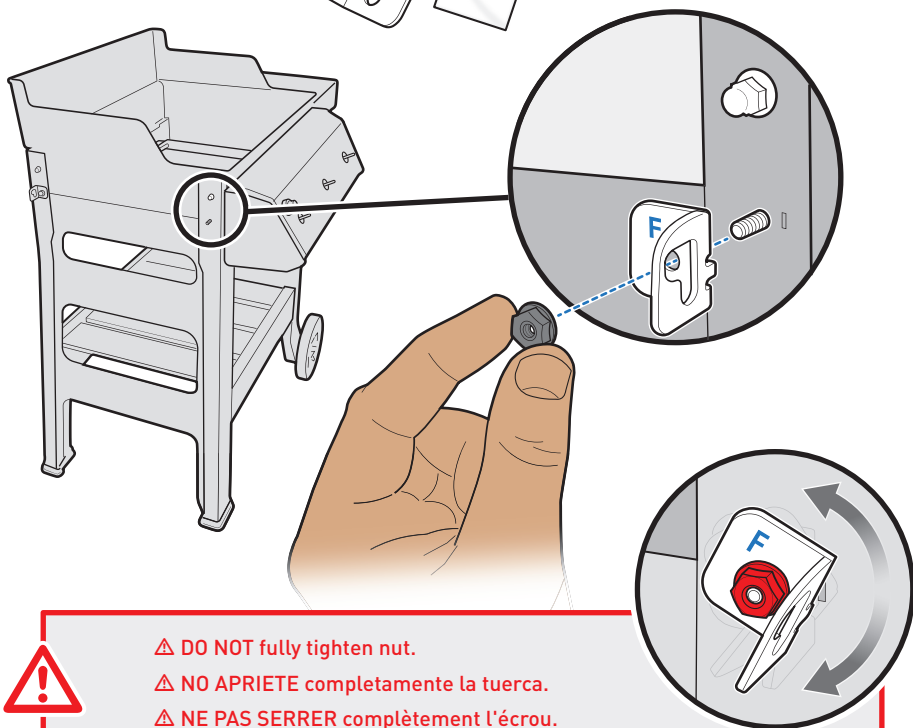
35**36**

- ⚠ DO NOT fully tighten nut.
- ⚠ NO APRIETE completamente la tuerca.
- ⚠ NE PAS SERRER complètement l'écrou.

37

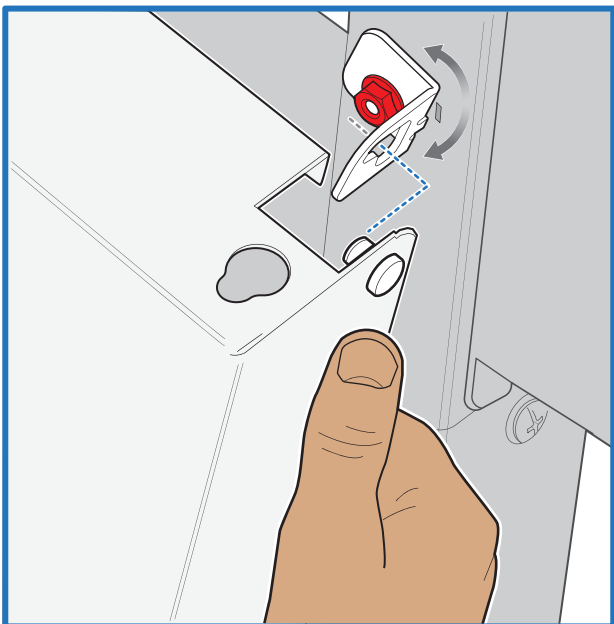
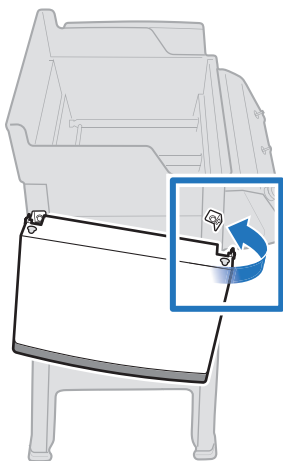
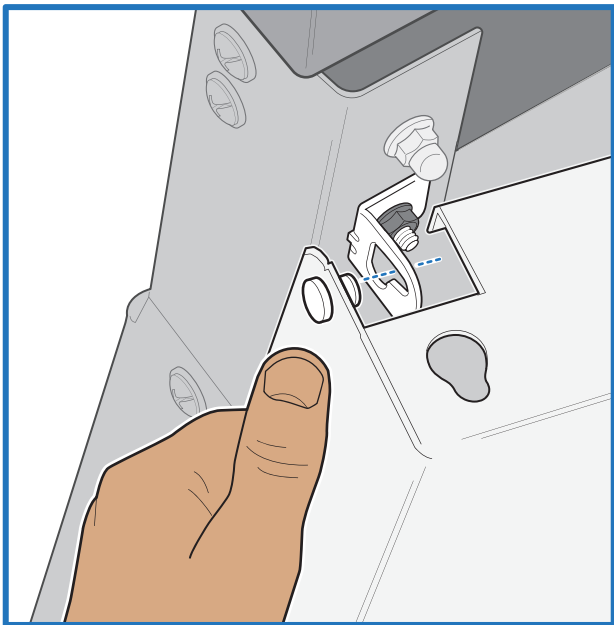
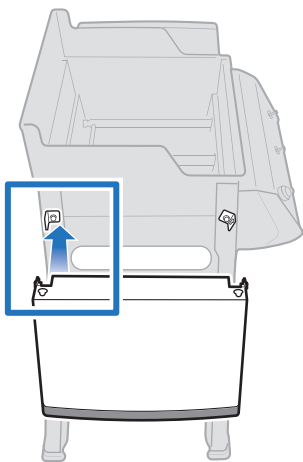

38



⚠ CAREFULLY raise side table, then fully tighten nut.

⚠ CON CUIDADO, levante la mesa lateral y apriete completamente la tuerca.

⚠ Soulever la tablette latérale AVEC PRÉCAUTION, puis serrer complètement l'écrou.

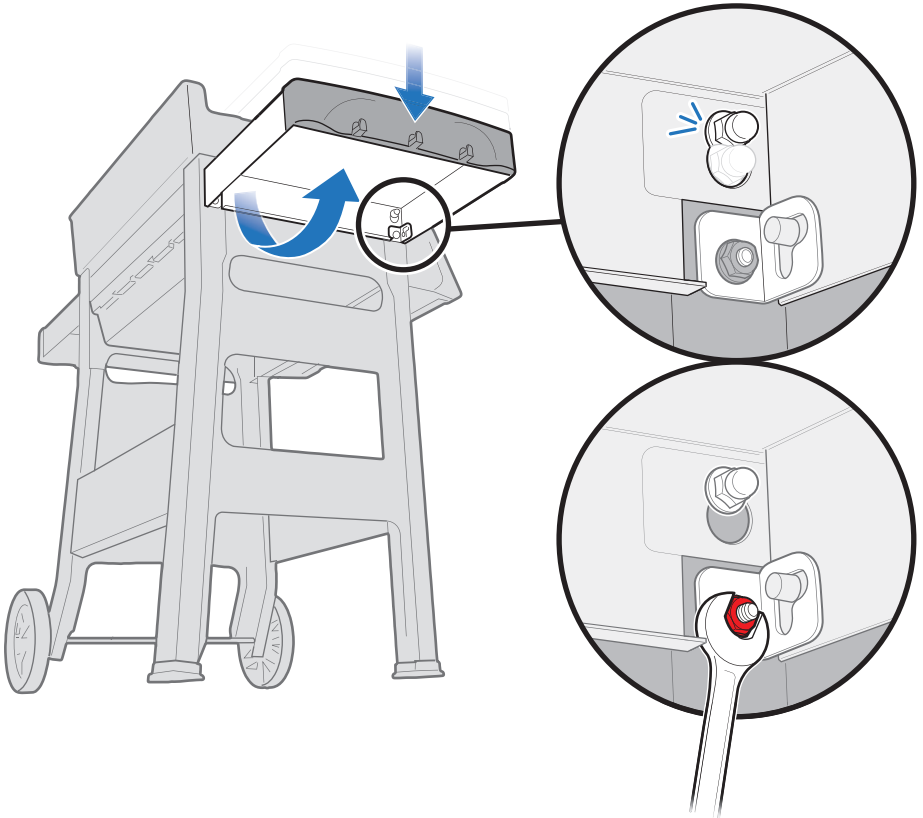

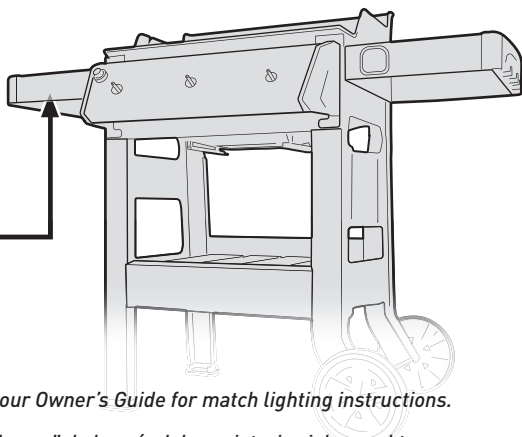
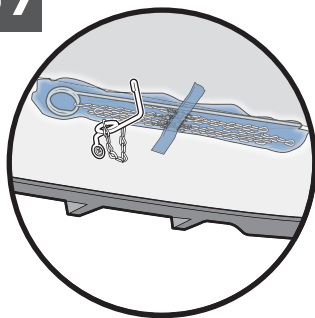
39

- Refer to the Troubleshooting section of your Owner's Guide for match lighting instructions.
- Consulte la sección "Resolución de problemas" de la guía del propietario si desea obtener información acerca del encendido con cerillos.
- Se reporter à la section Dépannage du manuel d'utilisation pour les instructions sur l'allumage avec des allumettes.

40

4- 4- 2-



- For Liquid Propane gas grills only.
- Sólo para barbacoas de gas propano líquido.
- Uniquement compatible avec les barbecues à gaz propane.

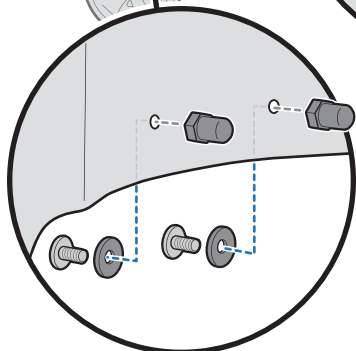
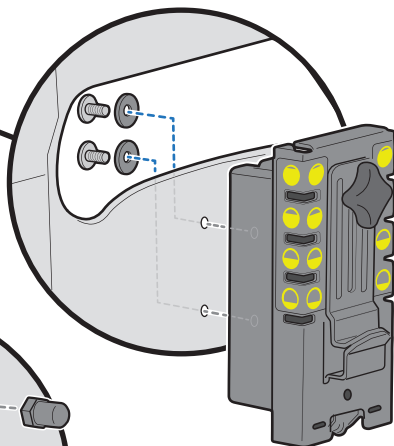
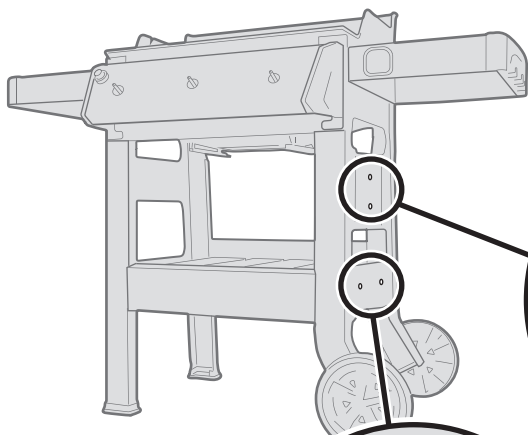

41

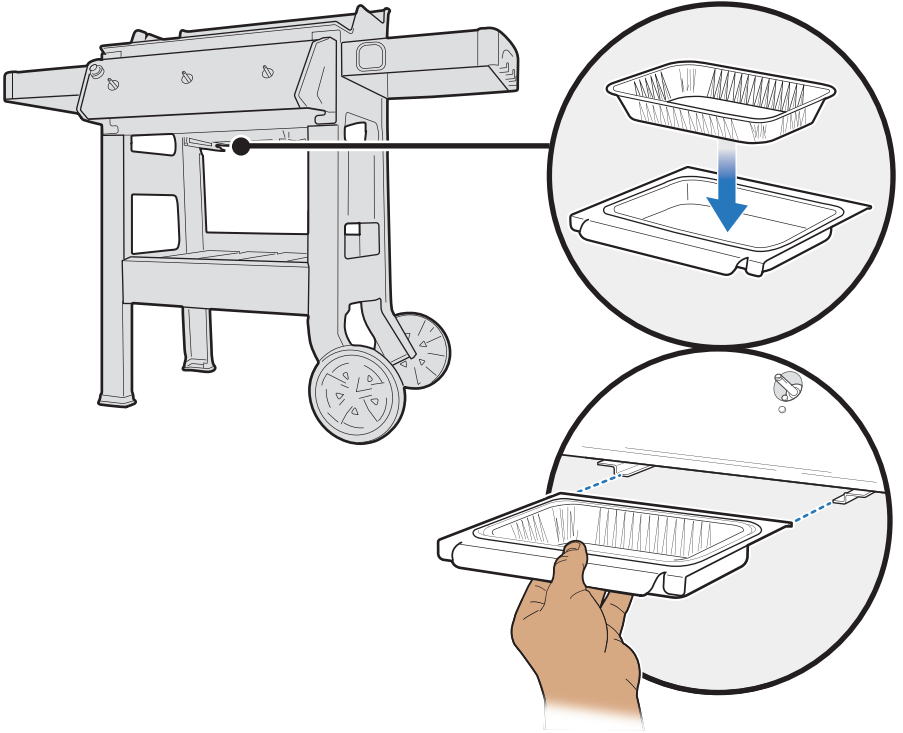

42

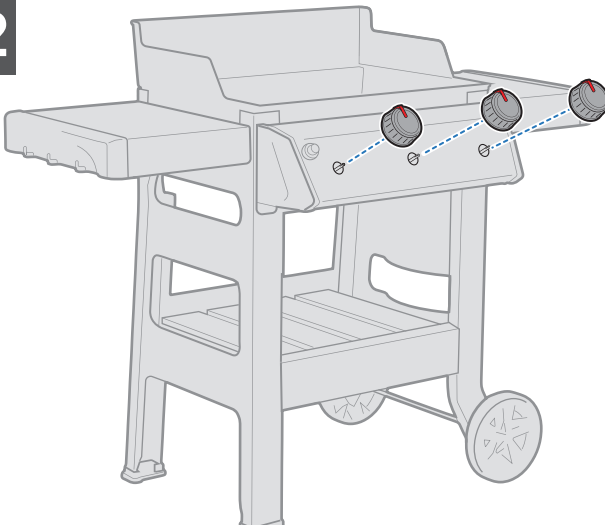

43

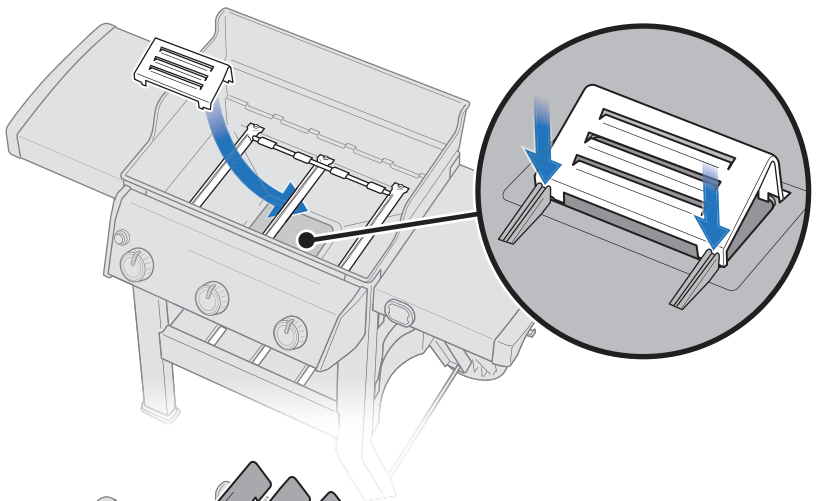

44

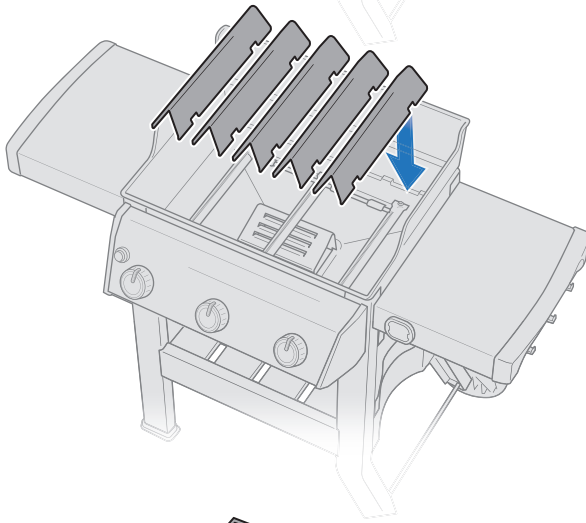

45

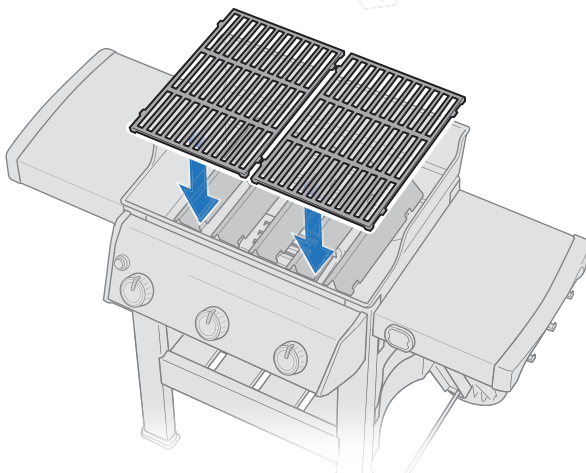

46

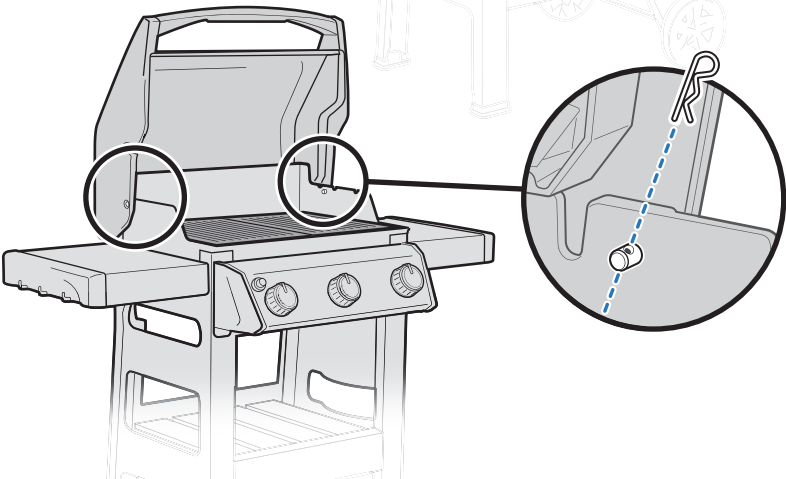
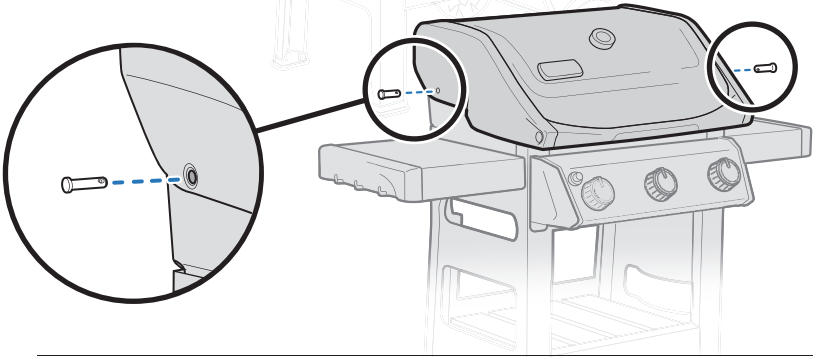
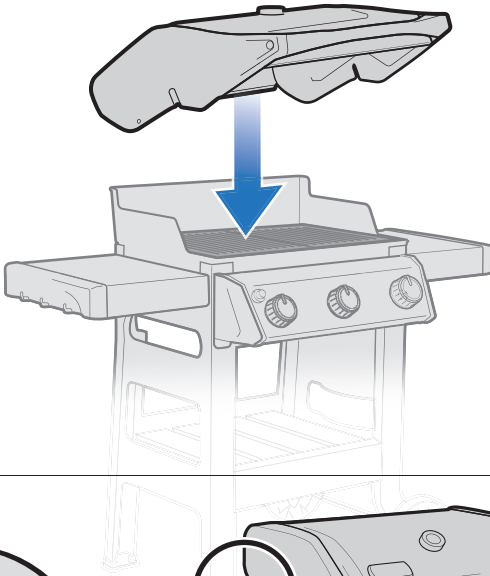

47

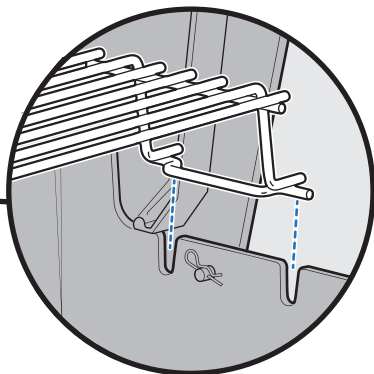
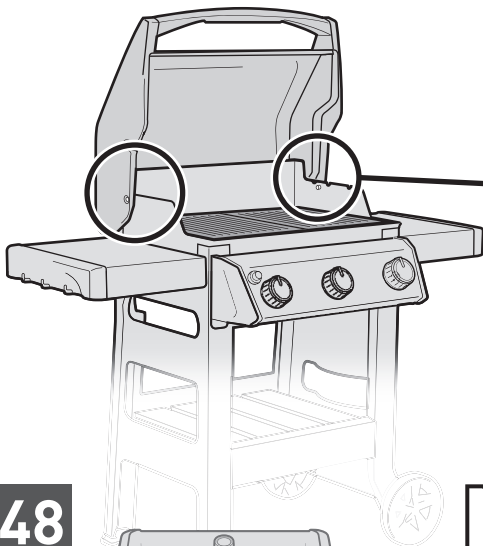
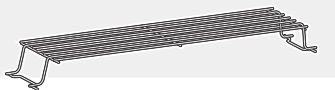

48

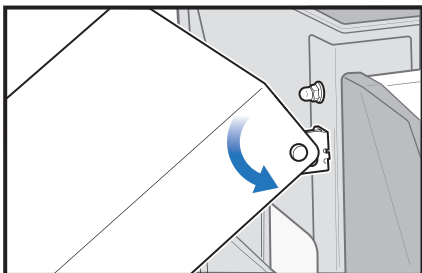
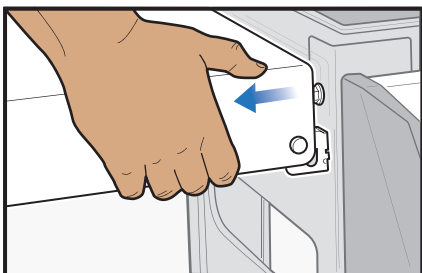
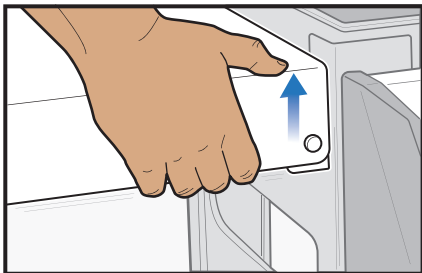
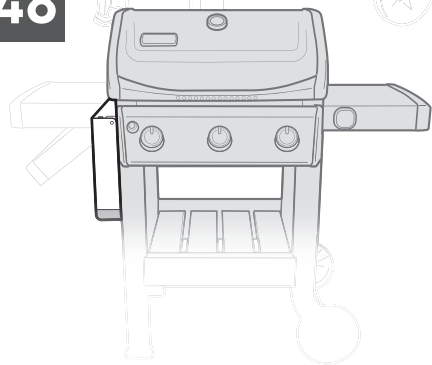

49

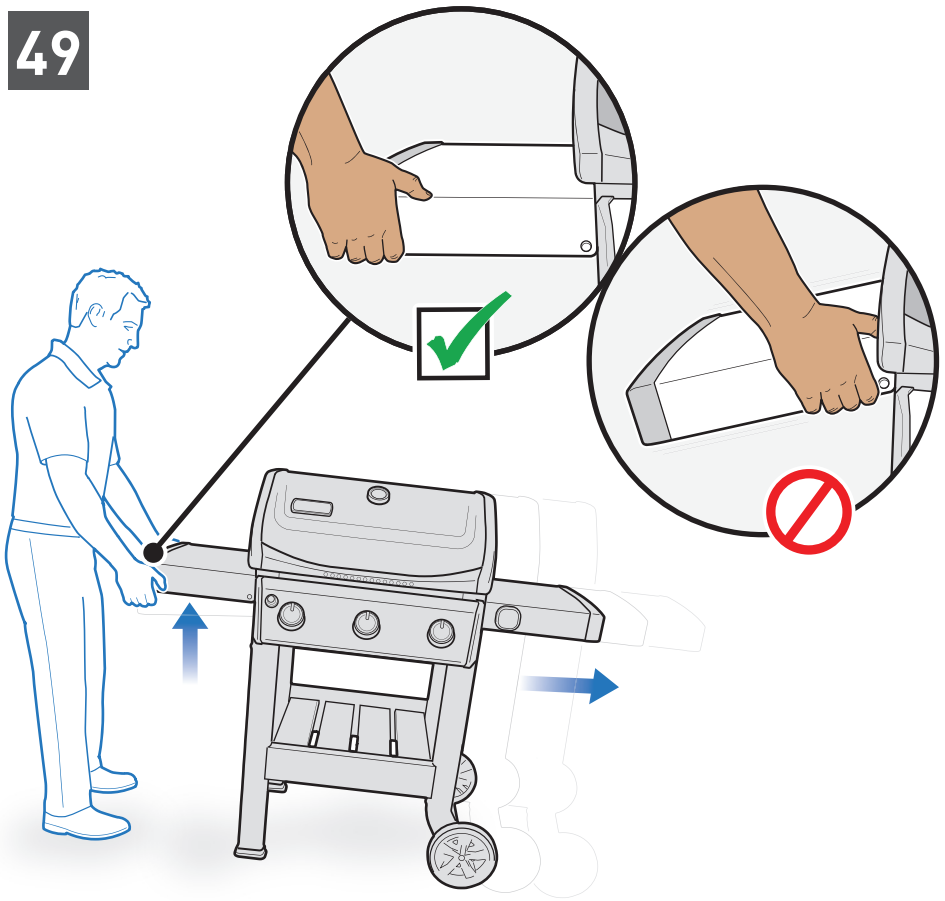

50

- Refer to the "Getting Started" section of your owner's manual for gas connections and leak checking.
- Consulte la sección "Primeros pasos" del manual del propietario para más información sobre las conexiones de gas y las pruebas de fugas.
- Pour de l'information sur les raccords de l'alimentation en gaz et sur la vérification des fuites, reportez-vous à la section « Démarrage » de votre manuel du propriétaire.

Register Today.
Regístrate hoy.
Enregistrez-le aujourd'hui.



U.S.:
1-800-446-1071

EE. UU.:
1-800-446-1071

États-Unis :
1 800 446-1071



Mexico:
01 800 0093237

México:
01 800 0093237

Mexique :
01 800 0093237



Canada:
1-800-446-1071

Canadá:
1-800-446-1071

Canada :
1 800 446-1071

Apple and the Apple logo are trademarks of Apple Inc., registered in the U.S. and other countries. App Store is a service mark of Apple Inc. Android and Google Play are trademarks of Google Inc.

Apple y el logotipo de Apple son marcas comerciales de Apple Inc., registradas en EE. UU. y otros países. App Store es una marca de servicio de Apple Inc. Android y Google Play son marcas comerciales de Google Inc.

Apple et le logo d'Apple sont des marques de commerce d'Apple Inc. déposées aux États-Unis et dans d'autres pays. App Store est une marque de service d'Apple Inc. Android et Google Play sont des marques de commerce de Google Inc.